

TRITON D8[®]

User Manual



ZEEMSGB343A Rev. A

Start 

Contents



Quick Links

Click a Topic

Using Page Controls   

Table of Contents (TOC)

General Information

Basic Operation & Navigation

Quick Reference Information

Maintenance

ShopStream Connect™

The Snap-on Cloud

Wi-Fi Connection

Customer Support / Training



Scanner

Intelligent Diagnostics

Vehicle Code Scan



OBD-II/EOBD



Guided Component Tests



Scope Multimeter



TSBs



Previous Vehicles & Data



Tools



Table of Contents

Safety Information	vi
Using This Manual	viii
Section 1: Quick Reference	1
Section 2: General Information	2
Basic Features	2
Powering the Diagnostic Tool	3
Vehicle Power	3
Internal Battery Pack	3
AC Power Supply	4
Technical Specifications	4
Section 3: Basic Operation and Navigation	5
Turning On/Off and Emergency Shutdown	5
Turning On	5
Turning Off	5
Emergency Shutdown	5
Control Buttons	6
Basic Navigation	6
Home Screen Layout.....	6
Home Screen Icons	7
Title Bar	7
Common Toolbar Control Icons	8
Scroll Bar	8
Screen Messages	8
Snap-on Messages	8
General System Messages	9
Vehicle Communication Messages	9
Section 4: Data Cable / Connections	10
Data Cable Connection (OBD-II/EOBD Vehicles).....	10
Section 5: Scanner	12
Basic Operation	12
Scanner Overview	12
Scanner - Starting / Stopping	13
Features and Icons	13
Scanner Features	13

Scanner Control Icons.....	14
Basic Scanner Operation (Quick Start).....	14
Vehicle Identification	15
System Selection	17
System Main Menu Options	18
Codes - View / Save	18
Codes Menu.....	18
Code Scan (with Vehicle System Report).....	20
Viewing and Saving Data (PIDs)	20
Data Menu	20
Data Views (List / Graph).....	26
Locking PIDs (to always display at top)	28
About the Data Buffer	28
About Cursors	29
Pausing and Reviewing Active Data	30
Saving Data Files	31
Using Zoom.....	33
Using Triggers.....	33
Functional Tests	37
Troubleshooter	38
Section 6: Vehicle Code Scan	40
Using Code Scan.....	41
Total Number of Systems (modules) Analyzed.....	42
List of All the Systems Analyzed with DTCs Totals.....	43
Global OBDII DTCs.....	43
Readiness Monitor Test Status	44
Vehicle System Report /	
Snap-on Cloud.....	44
Printing the Vehicle System Report	44
Section 7: Intelligent Diagnostics	45
Main Topic Links.....	45
Getting Started (Demonstration).....	46
Accessing Intelligent Diagnostics	47
Informative Messages	47
Using Intelligent Diagnostics (Code Results).....	47
Main Menu Navigation	48
Code Results Dropdown Menu.....	49



Top Repairs Graph 49

Technical Bulletins (OEM Information) 49

Smart Data 50

 About Smart Data PIDs 51

Functional Tests and Reset Procedures 51

Guided Component Tests (GCTs) 52

Real Fixes 53

Troubleshooter 54

Section 8: TSBs 56

 Operation 56

Section 9: OBD-II/EOBD 59

 Basic Operations 59

 Screen Layout and Toolbar Controls 59

 Connecting the Data Cable 59

 Saving and Reviewing Data Files 59

 OBD-II/EOBD Menu 60

 OBD Health Check 60

 OBD Direct 62

Section 10: Guided Component Tests 66

 Training and Classes 66

 Power User Tests 67

 Features and Benefits 67

 How To Guide 68

 Screen Layout and Icons 69

 Screen Layout 69

 Guided Component Tests Control Icons 69

 Operation 69

 Component Information 70

 Tests 71

 Saving and Reviewing Data Files 73

Section 11: Scope Multimeter 74

 Safety Information 74

 Measurement Out of Range Indicator 75

 Overview 75

 Digital Multimeter (DMM) 75

 Graphing Multimeter (GMM) 76

 Lab Scope 77

Tests and Capabilities (Quick Reference) 78

Test Leads and Accessories 79

 Channel 1 Lead 79

 Channel 2 Lead 79

 Alligator Clips and Probes 80

 Secondary Ignition Coil Adapter Lead and Clip-on Adapter (optional) 80

 Low Amp Current Probe (optional) 80

 Temperature Probe Adapter (optional) 80

 Pressure Transducers and Adapters (optional) 80

 Waveform Demonstration Tools (optional) 81

General Information 81

 Scope Multimeter Screen Layout and Features 81

Operation and Controls 83

 Test Lead / Probe Connection 83

 Test Lead / Probe Calibration 83

 Control Panel and Settings 84

 Secondary Ignition Testing 96

Optional Settings 97

 Display (Grid on/off) 97

 Divisions 98

Capturing Data 101

 About the Data Buffer 101

 Capturing Data (Capture Mode) 101

 Pausing Data 102

 Reviewing Data and Using Zoom (Review Mode) 102

Saving Data Files 105

Saving Screens 106

General Reference 106

 Basic Setup Tips (unknown signal type) 106

 Using Known Good Waveforms 107

 Troubleshooting Signals 107

 Units of Measurement / Conversions 108

 Glossary of Common Terms 109

Section 12: Previous Vehicles and Data 112

 Previous Vehicles and Data Menu 112

 Vehicle History 112

 View Saved Data 113

 Viewing Codes and Code Scan Results 113

 Delete Saved Data 115



Section 13: Tools 116

- Tools Menu 116
 - Connect-to-PC (File Transfer) 117
 - Get Connected 117
 - Configure Shortcut Button 117
 - System Information 117
 - Settings 118

Section 14: Wi-Fi Connection / Troubleshooting 124

- Checking if Wi-Fi is On/Off 124
- Checking if Wi-Fi is Connected 124
- Turning Wi-Fi On and Connecting to a Network 125
- Add Network Advanced (Connecting to a hidden network) 126
- Wi-Fi Testing 126
- Wi-Fi Troubleshooting and Status Messages 127
 - Informative Messages 129

Section 15: The Snap-on® Cloud 130

- Key Features 130
- Important Notes 130
- Registration - Getting Started 130
 - Snap-on Cloud - New User Registration 131
 - Snap-on Cloud Setup Information Screen 132
- Using the Snap-on Cloud 132
 - Logging in to Snap-on Cloud (registered user) 132
 - Navigating Snap-on Cloud (Toolbars) 133
 - My Files 133
 - Search 137
 - Shop Files 137
 - Favorites 139
 - Profile 139

Section 16: ShopStream Connect™ 144

- Using SSC (Connecting to your PC) 144
- SSC Main Screen 145
- Scanner DataViewer 146
- Image Viewer 146
- Printing the (Code Scan) Vehicle System Report 147
- Customizing the (Code Scan) Vehicle System Report 148
- Software Upgrades and Updates 150
 - End User License Agreement 150

Section 17: Maintenance 152

- Cleaning and Inspecting the Diagnostic Tool 152
 - Cleaning the Touch Screen 152
- Battery Pack Service 152
 - Safety 152
 - Ordering a New Battery Pack 153
 - Removing / Installing the Battery Pack 153
 - Disposing of the Battery Pack 154

Customer Support / Training 155

Legal Information 158



Safety Information

READ ALL INSTRUCTIONS

For your own safety, the safety of others, and to prevent damage to the product and vehicles upon which it is used, it is important that all instructions and safety messages in this manual and the accompanying *Important Safety Instructions* manual be read and understood by all persons operating, or coming into contact with the product, before operating. We suggest you store a copy of each manual near the product in sight of the operator.

For your safety, read all instructions. Use your diagnostic tools only as described in the tool user's manual. Use only manufacturer recommended parts and accessories with your diagnostic tools.

This product is intended for use by properly trained and skilled professional automotive technicians. The safety messages presented throughout this manual and the accompanying *Important Safety Instructions* manual are reminders to the operator to exercise extreme care when using this product.

There are many variations in procedures, techniques, tools, and parts for servicing vehicles, as well as in the skill of the individual doing the work. Because of the vast number of test applications and variations in the products that can be tested with this instrument, we cannot possibly anticipate or provide advice or safety messages to cover every situation. It is the responsibility of the automotive technician to be knowledgeable of the system being tested. It is essential to use proper service methods and test procedures. It is important to perform tests in an appropriate and acceptable manner that does not endanger your safety, the safety of others in the work area, the equipment being used, or the vehicle being tested.

It is assumed that the operator has a thorough understanding of vehicle systems before using this product. Understanding of these system principles and operating theories is necessary for competent, safe and accurate use of this instrument.

Before using the equipment, always refer to and follow the safety messages and applicable test procedures provided by the manufacturer of the vehicle or equipment being tested. Use the product only as described in its user manual. Use only manufacturer recommended parts and accessories with your product.

Read, understand and follow all safety messages and instructions in this manual, the accompanying *Important Safety Instructions* manual, and on the test equipment.

Environmental Conditions:

- This product is intended for indoor use only
- This product is rated for Pollution Degree 2 (normal conditions)

Safety Signal Words

All safety messages contain a safety signal word that indicates the level of the hazard. An icon, when present, gives a graphical description of the hazard. Safety Signal words are:



Indicates an imminently hazardous situation which, if not avoided, will result in death or serious injury to the operator or to bystanders.



Indicates a potentially hazardous situation which, if not avoided, could result in death or serious injury to the operator or to bystanders.



Indicates a potentially hazardous situation which, if not avoided, may result in moderate or minor injury to the operator or to bystanders.



Safety Message Conventions

Safety messages are provided to help prevent personal injury and equipment damage. Safety messages communicate the hazard, hazard avoidance and possible consequences using three different type styles:

- Normal type states the hazard.
- **Bold** type states how to avoid the hazard.
- *Italic type states the possible consequences of not avoiding the hazard.*

An icon, when present, gives a graphical description of the potential hazard.

Safety Message Example



Risk of electric shock.

- **Prior to recycling the battery pack, protect exposed terminals with heavy insulating tape to prevent shorting.**
- **Disconnect all test leads and turn diagnostic tools off before removing the battery pack.**
- **Do not attempt to disassemble the battery or remove any component projecting from or protecting the battery terminals.**
- **Do not expose the diagnostic tool or battery pack to rain, snow, or wet conditions.**
- **Do not short circuit the battery terminals.**

Electric shock can cause injury.

Important Safety Instructions

For a complete list of safety messages, refer to the accompanying *Important Safety Instructions manual*.

SAVE THESE INSTRUCTIONS

Using This Manual





Hyperlinks

Selectable hyperlinks are provided throughout this manual to quickly take you to related topics, procedures, and websites. Hyperlinks are identified by **Blue** colored text.

Text Hyperlink Example: <http://diagnostics.snapon.com>

Page Navigation Controls

The following navigation controls are provided on the top of each page of the user manual. They can be used in addition to the viewer controls in the toolbar.

Icon	Description
Quick Links Menu	Opens the Quick Links menu within the Table of Contents (TOC) section. From Quick Links you can link to most topics in this manual.
	
Jump Back	Click to move back one page.
	
Jump Forward	Click to move forward one page.
	

Content

This manual contains basic operating instructions and is structured in a manner to help you become familiar with your diagnostic tool features and perform basic operations.

The illustrations in this manual are intended as reference only and may not depict actual screen results, information, functions or standard equipment. Contact your sales representative for availability of other functions and optional equipment.

Conventions

The following conventions are used.

Terminology

The terms “Scanner” and “Scanner function” are used to describe the Scanner Function(s) of the diagnostic tool.

Examples:

- Select **Scanner** from the Home screen.
- From the Scanner main menu select **Continue**.
- The Scanner function provides many diagnostic tests.

The term “select” describes tapping/touching an icon on the touch screen, or highlighting an icon or menu choice and then selecting the confirmation menu choice such as **Continue, Accept, OK, Yes, or other similar** choice.

Abbreviated example for the following procedure: “Select **Brightness**”

1. Navigate to and highlight the **Brightness** selection.
2. Select **OK, or similar**, button.



Symbols

Different types of arrows are used. The “greater than” arrow (>) indicates an abbreviated set of selection (navigation) instructions.

Abbreviated example for the following procedure: “Select **Tools > Connect-to-PC**”

1. Select **Tools** from the home screen.
2. Highlight **Connect-to-PC** on the Tools menu.
3. Select **Connect-to-PC**.

The solid arrows (◀, ▶, ▼, ▲) are navigational instructions for the four directions of the directional buttons.

Example: Press the down ▼ arrow.

Bold Text

Bold emphasis is used in procedures to highlight selectable items such as control buttons, icons and menu options.

Example: Press the **OK** button

Notes and Important Messages

The following messages are used.

Notes

A NOTE provides helpful information such as additional explanations, tips, and comments.

Example:

i NOTE

For additional information refer to...

Important

IMPORTANT indicates a situation which, if not avoided, may result in damage to the test equipment or vehicle.

Example:

IMPORTANT

Do not disconnect the data cable while the diagnostic tool is communicating with the ECM.

IMPORTANT

Read all applicable [Safety Information](#) before using this diagnostic tool!

Procedures

An arrow icon in the left-margin area indicates a procedure.

Example:



To change screen views:

1. Select the **Graph** icon.
The dropdown menu displays.
2. Select an option from the menu.
The screen layout changes to the format selected.





Finding the Diagnostic Tool Serial Number and Software Version

The diagnostic tool serial number is located on the back of the diagnostic tool housing. The serial number can also be viewed onscreen from the System Information screen (**Tools > System Information**) see [System Information on page 117](#),

The diagnostic tool software version can be viewed onscreen from the System Information screen (**Tools > System Information**) see [System Information on page 117](#).

Connecting to Wi-Fi

Note: These instructions are intended as quick reference only, for additional information see [Wi-Fi Connection / Troubleshooting on page 124](#).

1. From the Home screen, select **Tools > Settings > Configure Wi-Fi**.
2. Select the **Wi-Fi** icon  to turn Wi-Fi on.
3. The Wi-Fi icon will change to , indicating Wi-Fi is on.
4. Select your wireless network from the list (*typical list shown below*), then select **Connect**.



Wi-Fi Applications

The following integrated Repair Information Applications provide up-to-date service/repair information directly to your diagnostic tool, via wireless network connection to our Snap-on Web Services Network:

- **Intelligent Diagnostics with SureTrack®**
- **TSBs**

To use these applications you must have authorized access. If your access to these applications has expired, contact your sales representative.

i NOTE

Performance varies depending on your wireless network equipment and ISP.

The Snap-on Cloud

This diagnostic tool includes a built-in Wi-Fi feature that automatically transfers code scan reports to the Snap-on Cloud. Use the Snap-on Cloud to print, transfer and send code scan reports.

The Snap-on Cloud is a mobile-friendly cloud-based application designed specifically for technicians to store, organize, share and print information. See [The Snap-on® Cloud on page 130](#) for additional information.

Printing Data and Screenshots

Use ShopStream Connect to print data files and screenshots from the diagnostic tool. See [ShopStream Connect™ on page 144](#).



The TRITON-D8 is a multi-functional diagnostic tool with exclusive Snap-on® features like Intelligent Diagnostics, TSBs and connection to the Snap-on Cloud.

This section describes basic feature locations, how the diagnostic tool is powered and basic specifications.

Main Topic Links

- [Basic Features](#) page 2
- [Powering the Diagnostic Tool](#) page 3
 - [Vehicle Power](#) page 3
 - [Internal Battery Pack](#) page 3
 - [AC Power Supply](#) page 4
- [Technical Specifications](#) page 4

2.1 Basic Features



- 1— Touch Screen
- 2— Control Panel

Figure 2-1 Front view



- 1— Built-in Stand
- 2— Battery Cover

Figure 2-2 Back view

Connectors and jacks for data communication cables and the AC power supply are located on the top of the diagnostic tool.



Figure 2-3 Top view

- 1— **Battery Status Indicator LED**
- 2— **Power Supply Jack** - AC power supply connection
- 3— **Scope/Multimeter Jacks** - Scope and multimeter lead connections
- 4— **Mini USB Jack** - USB cable connection used to transfer saved data files to a personal computer
- 5— **Micro secure digital (uSD) Card** - contains operating system programming. **IMPORTANT** The uSD card must be installed for the diagnostic tool to operate. Do not remove the uSD card while the diagnostic tool is powered on.
- 6— **Data Cable Connector** - Data cable connection used to connect the diagnostic tool to a vehicle data link connector (DLC)

2.2 Powering the Diagnostic Tool

Your diagnostic tool can receive power from any of the following sources:

- [Vehicle Power](#)
- [Internal Battery Pack](#)
- [AC Power Supply](#)

2.2.1 Vehicle Power

The diagnostic tool is designed to be powered from the vehicle. All OBD-II/EOBD vehicles have vehicle battery power (B+) available on the data link connector (DLC). The diagnostic tool is powered through the Data Cable when connected to the vehicle DLC.

A green LED indicator on the DLC end of the data cable, illuminates when power is being supplied to the cable. If the LED fails to illuminate, check that the data cable

is properly connected and then check the DLC power circuit. See [Data Cable / Connections](#) on page 10 for additional data cable information.

An optional power cable is required when testing non-OBD-II/EOBD or models that do not have vehicle battery power (B+) available on the DLC. Contact your sales representative for availability.

IMPORTANT

Never connect the optional power cable to the power supply input jack on the diagnostic tool when the diagnostic tool is communicating with a vehicle.

2.2.2 Internal Battery Pack

The diagnostic tool can be powered from the internal rechargeable battery pack. A fully charged battery pack provides sufficient power for about 3 hours of continuous operation. For battery pack removal and installation instructions see, [Removing / Installing the Battery Pack](#) on page 153.

Battery Pack Charging



Battery charging occurs whenever the data cable is connected to a vehicle DLC. Battery charging also occurs when the AC power supply is connected to a live AC power source, and connected to the diagnostic tool. Use the supplied AC power supply to charge the battery pack.

Insert the end of the AC power supply cable into the diagnostic tool power supply jack, then connect the AC power supply to an approved AC power source.

IMPORTANT

Only use the supplied AC power supply. Never connect the power supply to the diagnostic tool when the tool is communicating with a vehicle.

The Battery Status Indicator LED (located next to the power supply jack) indicates battery status.

Battery Status LED	Description
	Green - battery is fully charged, or the diagnostic tool is being powered by the AC power supply.
	Red - battery is charging
	Amber - indicates a battery issue. This is usually caused by excessive battery temperature (above 104°F/40°C), which disables charging. Allow the diagnostic tool to cool down before continuing operation.

2.2.3 AC Power Supply

The diagnostic tool can be powered from a standard AC outlet using the AC power supply. The AC power supply converts alternating current (AC) to direct current (DC) to power the diagnostic tool. The connector on the end of the output cable of the AC power supply connects to the AC power supply jack on top of the diagnostic tool. Use only the AC power supply provided.

IMPORTANT

Never connect the AC power supply to the diagnostic tool when the diagnostic tool is communicating with a vehicle.

2.3 Technical Specifications

Item	Description / Specification
Touch Screen	Resistive Touch Panel
Display	8.0 inch diagonal, Color LCD
	800 x 480 resolution SWVGA
Meter	Meter Category 1
Battery	Rechargeable lithium-ion battery pack
	Approximately 3 hour run time
	Approximately 5 hour charge time
Power Supply	Supply Rating; 15VDC, 2A
DC Operating Voltage	10 to 30VDC
Width	11.06 in. (281.0 mm)
Height	6.29 in. (160.0 mm)
Depth	1.58 in. (40.3 mm)
Weight (including battery):	2.65 lb (1.20 kg)
Operating Temperature Range (ambient)	At 0 to 90% relative humidity (non-condensing) 32 to 113°F (0 to 45°C)
Storage Temperature (ambient)	At 0 to 70% relative humidity (non-condensing) -4 to 140°F (-20 to 60°C)
Operating Altitude	Maximum 2000 m
Environmental Conditions	This product is intended for indoor use only
	This product is rated for Pollution Degree 2 (normal conditions)

This section describes basic diagnostic tool operation, navigation, screen layout, icon functions, and screen messages. Before you operate the diagnostic tool, make sure the battery pack is fully charged or the diagnostic tool is powered by the AC power supply.

Main Topic Links

- [Turning On/Off and Emergency Shutdown](#) page 5
- [Control Buttons](#) page 6
- [Basic Navigation](#) page 6
- [Home Screen Icons](#) page 7
- [Common Toolbar Control Icons](#) page 8
- [Screen Messages](#) page 8

3.1 Turning On/Off and Emergency Shutdown

The following sections describe how to turn the diagnostic tool on and off and how to perform an emergency shutdown.

3.1.1 Turning On

To manually turn on the diagnostic tool, press and release the **Power** button (*Figure 3-1*).

The diagnostic tool will automatically turn on when:

- a live AC power supply is connected to the diagnostic tool
- the Data Cable is connected to a vehicle (that has 12VDC at the data link connector (DLC))

3.1.2 Turning Off

IMPORTANT

*All vehicle communication must be stopped **BEFORE** turning off the diagnostic tool. A warning message displays if you attempt to turn the diagnostic tool off while communicating with the vehicle. Forcing a shut down while communicating may lead to ECM problems on some vehicles. Never disconnect the Data Cable when the diagnostic tool is communicating with the vehicle ECM.*



To turn off the diagnostic tool:

1. Press the **N/Cancel** button or select the **Back** or **Home** icon to navigate to the Home screen.
If applicable, a “stopping communication” message appears briefly before the Home screen displays.
2. If applicable, disconnect the Data Cable from the vehicle.
3. Press and release the **Power** button.
A confirmation screen displays.
4. Press the **Y/Accept** button or select **OK** from the menu to turn the diagnostic tool off. To continue operating, press the **N/Cancel** button or select **Cancel** from the menu.

3.1.3 Emergency Shutdown

IMPORTANT

Using the emergency shutdown procedure while communicating with the vehicle ECM may lead to ECM problems on some vehicles.

During normal operation turn the diagnostic tool off using the *Turning Off* procedure above. The emergency shutdown procedure should only be used if the diagnostic tool does not respond to navigation or control buttons or exhibits erratic operation. To force an emergency shutdown, press and hold the **Power** button for five seconds until the diagnostic tool turns off.

3.2 Control Buttons

There are four “push type” control buttons and one “thumb pad rocker type” multi-directional button located on the right side of the diagnostic tool. All other diagnostic tool operations are controlled through the touch screen.



Figure 3-1 Front view

Item	Button	Description
1		N/Cancel - Push type button <ul style="list-style-type: none"> To exit a menu or program. To close an open list and return to the previous menu or screen. To answer “No” when a yes/no choice is given.
2		Y/Accept - Push type button <ul style="list-style-type: none"> To confirm a selection from a menu or program. To select an item that was highlighted using the direction arrows. To advance to the next screen in a series. To answer “Yes” when a yes or no choice is given.

Item	Button	Description
3		Directional - Thumb pad rocker type buttons <p>Buttons move the cursor or highlight in their respective direction:</p> <ul style="list-style-type: none"> Up (▲) Down (▼) Left (◀) Right (▶)
4		S (Shortcut) - Push type button <p>Programmable function button that can provide a shortcut for performing a variety of routine tasks. Refer to Configure Shortcut Button on page 117 for additional information.</p>
5		Power (On/Off) - Push type button <p>Turns the diagnostic tool on and off. Also, press and hold for 5 seconds for emergency shutdown.</p>

3.3 Basic Navigation

3.3.1 Home Screen Layout

The Home screen includes a title bar and main body. The Home screen contains the primary diagnostic tool function icons.

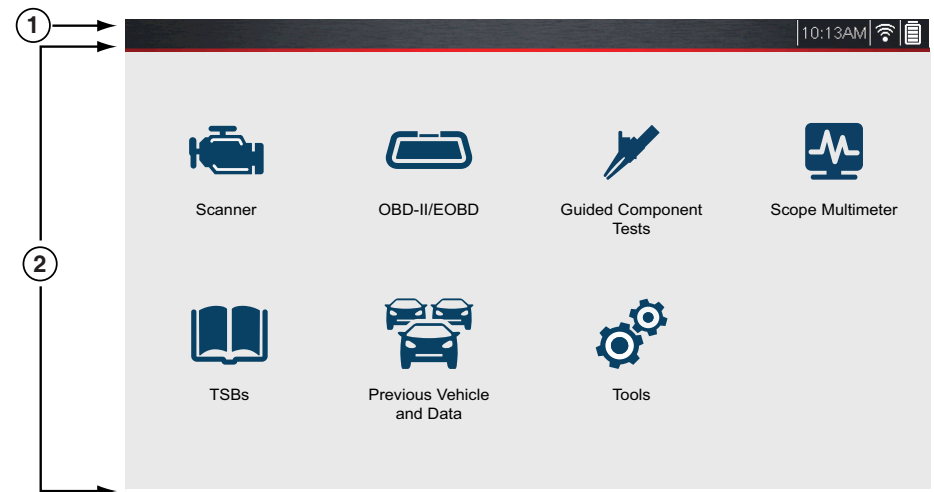

- 1— Title Bar
- 2— Main Body

Figure 3-2 Home screen



3.3.2 Home Screen Icons

Each available diagnostic tool function is represented by a icon on the Home screen. Select an icon from the Home screen to start a function. You can also use the control buttons to select an icon. Use the directional button to highlight the desired function and then press the **Y/Accept** to select it.

Function Name	Function Icon	Description
Scanner		Used to communicate with the electronic control systems of a vehicle. This function allows you to retrieve diagnostic trouble codes (DTCs), view PID data and perform diagnostic tests. See Scanner on page 12 for details.
OBD-II/EOBD		Allows you to access generic OBD-II/EOBD data and tests without identifying the vehicle being tested. See OBD-II/EOBD on page 59 for details.
Guided Component Tests		Allows you to perform diagnostic tests for the identified vehicle.
Scope Multimeter		Allows you to perform lab scope, graphing multimeter and digital multimeter tests and measurements.
TSBs		Provides quick access to the OEM technical service bulletin information. See TSBs on page 56 .

Function Name	Function Icon	Description
Previous Vehicles & Data		Allows you to quickly reconfigure the diagnostic tool to a recently tested vehicle and to access saved data files. See Previous Vehicles and Data on page 112 for details.
Tools		Allows you to adjust diagnostic tool settings to your personal preferences and perform other special functions. See Tools on page 116 for details.

3.3.3 Title Bar

The title bar ([Figure 3-3](#)) at the top of the screen provides basic information about current diagnostic tool operating conditions. Title bar options vary depending upon vehicle make and model, what function is active, what test is being performed, or what menu is selected. The title bar contains information only, there are no selectable items.



Figure 3-3

Elements of the Title bar let you know at a glance:

- Which diagnostic tool function is active
- The current time
- Wi-Fi signal strength
- The source and status of the power being supplied to the diagnostic tool

A real time clock displays to the left of the power supply icon. The clock is powered by a dedicated internal battery, so the correct time is maintained even when the main battery pack is discharged. Use the Tools function to set the clock and format how time is displayed. See [Clock Settings on page 121](#) for additional information.

The Title bar displays other information that varies depending upon what functions are being performed. Other information may include:

- The identification (ID) of the test vehicle



- The name of the active menu or function
- The name of the test being performed

Icon	Function	Icon	Function
	Full Battery Charge Level - Indicates power is being supplied by the internal battery pack. Horizontal bars diminish as the battery discharges.		External Power Connected - Indicates power is being supplied through the data cable connection to a vehicle or by the AC Power Supply and charging the battery pack.
	Low Battery Charge Level - Indicates the internal battery pack is low and needs to be recharged immediately. A warning message will also display on the screen when the battery gets low.		Wi-Fi Signal Strength - Indicates signal strength of the wireless network connection. 3 bars - full strength signal 1 bar - weak signal

3.3.4 Common Toolbar Control Icons

Common control icon functions are described in the following table. Specific function control icons are described in their applicable sections. Displayed control icons vary depending on the active function or test.

Select a control icon to perform a function. You can also use the control buttons to select an icon. Use the directional button to highlight the desired function and then press the **Y/Accept** button to select it.

Icon	Function	Icon	Function
	Home - Returns to the Home screen. Icon is located next to the Back icon on the left side of the toolbar.		Pause - Pauses active data collection.
	Save - Writes data from buffer memory to a file. The saved "movie" file can be accessed for future reference by selecting Previous Vehicles and Data > View Saved Data .		Start (Capture) - Resumes active data collection.
-	-		Tools - Opens the tools menu.

3.3.5 Scroll Bar

A vertical scroll bar appears along the right-hand edge of the screen when additional data expands above or below what is currently on the screen (*Figure 3-4*).

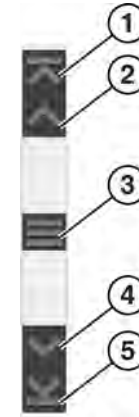

Figure 3-4 Scroll bar

- 1— **Beginning** - Moves to beginning of data displayed.
- 2— **Step up** - Moves up one increment of the data displayed.
- 3— **Slider (position indicator)** - Select and drag the **Slider** to scroll through data. The slider indicates the relative position of the current screen to the total available data.
- 4— **Step down** - Moves down one increment of the data displayed.
- 5— **End** - Moves to end of data displayed.

The Up and Down directional buttons can also be used to move through the data one line at a time. Press and hold a directional button to rapidly scroll through data.

3.4 Screen Messages

3.4.1 Snap-on Messages

Periodically messages will be displayed to inform you of software updates and upgrades, as well as other important information.

These messages require confirmation to resume tool operation. Select **Confirm** or **OK** to resume operation.



3.4.2 General System Messages

There are four types of general system messages that may be displayed:

Message Type	Description
Loading and Connecting	Loading and connecting messages display when the diagnostic tool is performing an internal operation, such as loading a database, establishing communications with the vehicle, or initiating a test. The message automatically clears once the internal operation is complete.
Confirmation	Confirmation messages inform you when you are about to perform an action that cannot be reversed or when an action has been initiated that requires a confirmation to continue. When a response is not required, the message displays briefly, then disappears.
Warning	Warning messages inform you when completing the selected action may result in an irreversible change or in the loss of data. A confirmation is required to continue.
Error	Error messages inform you when a system or procedural error has occurred, for example if the data cable becomes disconnected during operation.

3.4.3 Vehicle Communication Messages

When “no communication” messages are displayed, it indicates the diagnostic tool and the vehicle electronic control module are not communicating.

The following conditions cause “no communication” messages to display:

- The diagnostic tool is unable to establish a communication link with the vehicle.
- The vehicle is not equipped with the system that was selected.
- There is a loose connection.
- There is a blown vehicle fuse.
- There is a wiring fault on the vehicle.
- There is a circuit fault in the data cable or adapter.
- Incorrect vehicle identification was entered.

Refer to the Vehicle Communication Software manuals for manufacturer-specific problems.



This section describes basic data cable connection.

Connection of the data cable to the diagnostic tool and vehicle data link connector (DLC) is required for diagnostic tool operations that require communication with the vehicle.

4.1 Data Cable Connection (OBD-II/EOBD Vehicles)

IMPORTANT

Only use original Snap-on data cables and accessories with your diagnostic tool. Total data cable length must not exceed 114.17 inches (2.9 meters).



Basic data cable connection procedure:

For OBD-II/EOBD compliant vehicles use the supplied DA-4 data cable.

1. Connect the data cable to the diagnostic tool ([Figure 4-1](#)).



Figure 4-1 DA-4 data cable (26-pin end) connection to diagnostic tool

2. After identifying the vehicle using the Scanner or OBD-II/EOBD function (see [Vehicle Identification](#) on page 15) review any on-screen information that may be provided for data cable connection, usage and DLC location ([Figure 4-2](#)).

NOTE

On-screen cable and adapter connection instructions may be provided while using the Scanner and OBD-II/EOBD functions. The instructions may also include the location of the vehicle DLC.

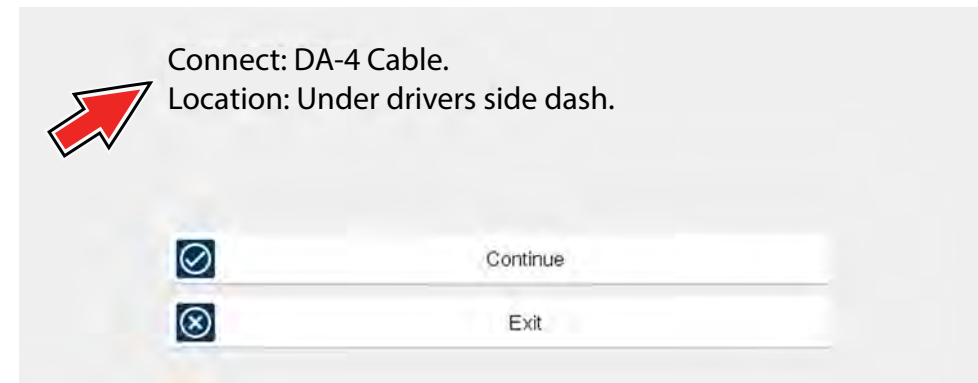

Figure 4-2 Vehicle data cable connection information

NOTE

The supplied 9 ft. (2.7 m) DA-4 data cable, includes an LED flashlight on the vehicle DLC connector end ([Figure 4-3](#)). The LED flashlight is powered by the diagnostic tool battery.



3. If needed, press the LED flashlight button switch on the end of the data cable to turn the LED flashlight on ([Figure 4-3](#)), and locate the DLC.



Figure 4-3 DA-4 data cable LED flashlight

4. Connect the 16-pin (J-1962) end of DA-4 cable ([Figure 4-4](#)) to the vehicle DLC.

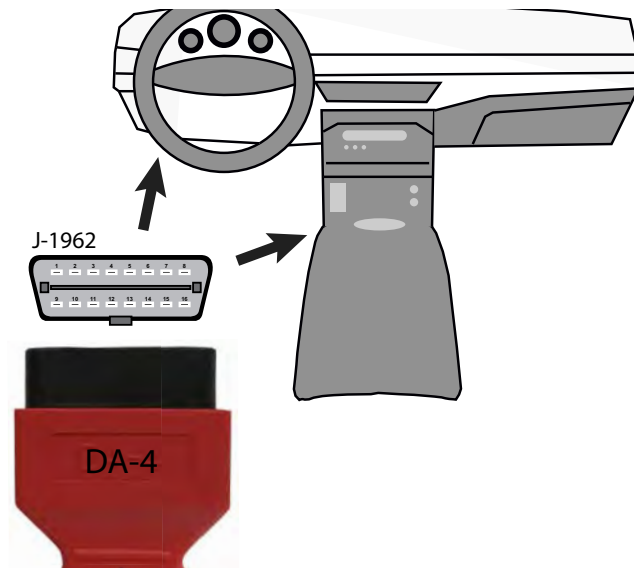

Figure 4-4 DA-4 data cable (16-pin end) connection to vehicle DLC (typical DLC locations)

5. Select **Continue** once the data cable is connected.

The diagnostic tool establishes communication with the vehicle, then displays a list of available tests, see [Scanner](#) on page 12 for additional information.



This section describes the basic operation of the Scanner function.



The **Scanner** icon is located on the Home screen.

The Scanner function allows your diagnostic tool to communicate with the electronic control modules (ECMs) of the vehicle being serviced. This allows you to perform tests, view diagnostic trouble codes (DTCs), and live data parameters from various vehicle systems such as the engine, transmission, antilock brake system (ABS) and more.

Main Topic Links

- [Features and Icons](#) page 13
- [Scanner - Starting / Stopping](#) page 13
- [Scanner Control Icons](#) page 14
- [Basic Scanner Operation \(Quick Start\)](#) page 14
- [Vehicle Identification](#) page 15
- [System Main Menu Options](#) page 18
- [Codes Menu](#) page 18
- [Codes - View / Save](#) page 18
- [Code Scan \(with Vehicle System Report\)](#) page 20
- [Viewing and Saving Data \(PIDs\)](#) page 20
- [Using Triggers](#) page 33
- [Trigger Description and Features](#) page 33
- [Functional Tests](#) page 37

5.1 Basic Operation

5.1.1 Scanner Overview

Scanner is a menu driven application that communicates with vehicle control modules to access diagnostic trouble codes (DTCs), parameter data (PIDs), functional tests, and more. To navigate the application, use your fingertip or the control buttons to make onscreen menu selections to access the desired data, test or function.

Screen messages appear when additional input is needed before proceeding. There are three types of on-screen messages; confirmations, warnings, and errors.

- **Confirmation Messages** - Confirmation messages inform you when you are about to perform an action that cannot be reversed or when an action has been initiated and your confirmation is needed to continue. When a user-response is not required to continue, the message displays briefly before automatically disappearing.
- **Warning Messages** - Warning messages inform you when completing the selected action may result in an irreversible change or loss of data.
- **Error Messages** - Error messages inform you when a system or procedural error has occurred. Examples of possible errors include a disconnected cable or a peripheral, such as a printer, is powered off.

5.1.2 Scanner - Starting / Stopping

- To start the Scanner function:**
- From the Home screen, select the **Scanner** icon.
The vehicle identification process starts. The vehicle must be correctly identified for the diagnostic tool to communicate, and display data correctly.
 - Follow the onscreen instructions to identify the vehicle and connect the data cable. See [Vehicle Identification](#) on page 15.

NOTE

Damage to the vehicle electronic control module (ECM) may occur if communication is disrupted. Make sure the data cable is properly connected at all times during testing. Exit all tests before disconnecting the data cable or powering down the diagnostic tool.

The Scanner function remains open as long as there is an active communication link with the vehicle. You must interrupt this communication link in order to exit from tests and power down the diagnostic tool. A warning message displays if you attempt to shut down while the diagnostic tool is communicating with the vehicle.

- To exit the Scanner function:**
- From any active Scanner screen, select the **Back** icon on the toolbar.
The “stopping communications” message briefly displays followed by the Data menu.
 - From the Data Menu, select **Back** on the toolbar.
The “stopping communications” message displays again, then the Main menu. Once the Main menu is displayed, communication has been terminated and it is safe to return to the Home screen and power down the diagnostic tool.

5.2 Features and Icons

The following general features and control icons apply to both the Scanner and the OBD-II/EOBD functions.

5.2.1 Scanner Features

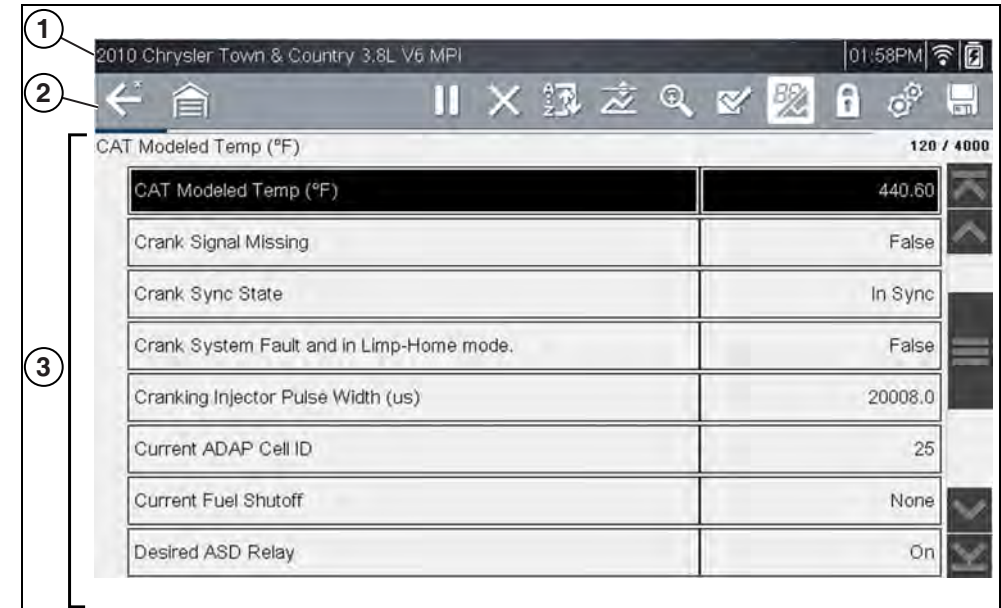

- 1— Title bar**—shows active test, vehicle and diagnostic tool status. The Title bar appears for all functions and displays information only, there are no selectable items. See [Title Bar](#) on page 7.
- 2— Toolbar**—contains control icons
- 3— Main body**—displays menus, code results, PIDs, etc.

Figure 5-1 Scanner screen features



5.2.2 Scanner Control Icons

The scanner toolbar contains control icons. Control icons may vary depending on the active function or test. An inverted (highlighted) icon indicates it is selected. Other control icons (not shown) are described in [Common Toolbar Control Icons on page 8](#).

Icon	Function	Icon	Function
	Pause - Pauses active data collection.		Start (Capture) - Resumes active data collection.
	Clear - Erases all the PID data in the buffer and begins a new recording. Selecting opens a confirmation message.		Custom Data List - Opens a menu for selecting which PIDs display in the list.
	Trigger - Opens a menu that allows you to set, arm, and clear threshold values that automatically trigger PID data to be saved from buffer memory to a file.		Change View - Changes display options between PID list or graph displays.
	Zoom - Incrementally increases and decreases the scale of the data being displayed.		Lock/Unlock - Locks or unlocks the highlighted parameter. Locked PIDs move to the top of the list and do not scroll as you move through the data.
	Step Forward - Allows forward movement in singular steps. <i>(Note: To quickly step forward during Scanner data review, press and hold the icon down.)</i>		Sort - Determines the order in which PIDs are listed on the screen.

Icon	Function	Icon	Function
	Skip Forward - Allows forward movement in multiple steps.		Step Back - Allows backward movement in singular steps. <i>(Note: To quickly step backward during Scanner data review, press and hold the icon down.)</i>
	Help - Opens the Getting Started with Intelligent Diagnostics slideshow. See Getting Started (Demonstration) on page 46 .		Skip Back - Allows backward movement in multiple steps.

5.2.3 Basic Scanner Operation (Quick Start)

This section lists the basic scanner operation steps, and is only intended as a quick-start reference. Refer to the supporting topics in this section for detailed operation information.



Getting Started (Basic Steps)

i NOTE

Menus, options and procedures may vary by vehicle. The following instructions apply to most OBD-II vehicles. Not all vehicles support the Auto ID and, or Instant ID feature.

1. Turn the vehicle ignition switch on.
2. Connect the data cable to the vehicle DLC. See [Data Cable / Connections on page 10](#).
The diagnostic tool will turn on automatically when connected to the vehicle.
3. Select **Scanner** from the Home screen.

i NOTE

While using the Scanner and OBD-II/EODB functions, on-screen data cable connection instructions are provided. The instructions may include the location of the vehicle DLC.

4. Depending on the vehicle, Instant ID may occur. See [Instant ID on page 16](#) for additional information.



5. If Instant ID is not supported, after selecting vehicle make (and year if needed), choose **Automatic ID** or **Manual ID** and enter the vehicle information at the screen prompts to continue. See [Vehicle Identification](#) on page 15.
If Automatic ID is selected, the identification process automatically completes (if supported by the vehicle).
6. Select a **Vehicle System** (e.g. Engine, Transmission).
7. Select a **Vehicle System Test/Function** (e.g. Codes Menu) to perform. See [System Main Menu Options](#) on page 18.

5.2.4 Vehicle Identification

The vehicle must be correctly identified for the diagnostic tool to communicate, and display data correctly. Menus and navigation will vary by vehicle.

Depending on the vehicle, the vehicle identification process may require manual entry of the vehicle information, or it may be automated. The following three Scanner functions are available to identify the vehicle:

Instant ID - Automatically completes the identification process upon initial communication between diagnostic tool and the vehicle using OBD-II VIN mode \$09. Instant ID requires specific vehicle support and procedures, see [Instant ID](#) on page 16 for additional information.

Auto ID - Automatically completes the identification process after the vehicle make and year are manually entered.

Manual ID - Allows for manual entry of all required vehicle identification criteria.



Use the following procedure to identify a vehicle.

NOTE

The following procedure applies to most OBD-II vehicles, and may vary depending on the vehicle. Not all vehicles support the Instant ID and/or Auto ID functions.

1. Connect the data cable to the diagnostic tool. See [Data Cable Connection \(OBD-II/EOBD Vehicles\)](#) on page 10.
2. Turn the vehicle ignition switch on.
3. Connect the data cable to the vehicle data link connector (DLC). See [Data Cable Connection \(OBD-II/EOBD Vehicles\)](#) on page 10.

NOTE

On-screen cable and adapter connection instructions may be provided while using the Scanner and OBD-II/EOBD functions. The instructions may also include the location of the vehicle DLC ([Figure 5-2](#)).

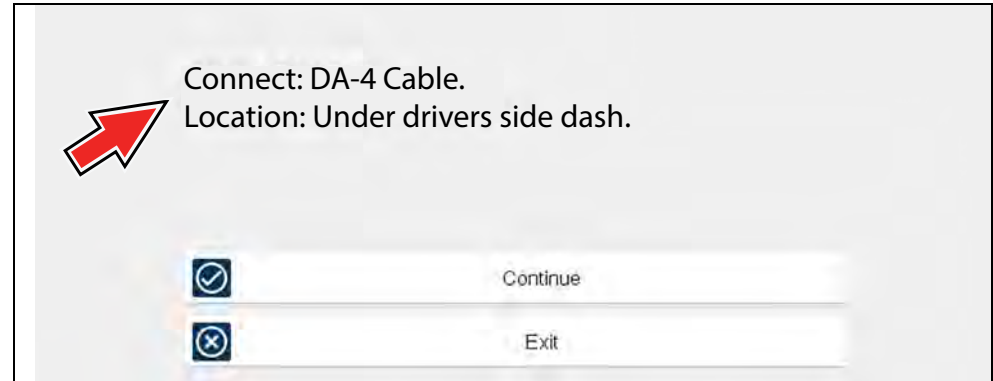

Figure 5-2 Vehicle connection data cable message

4. If the diagnostic tool is off, when the OBD-II data cable is connected to the vehicle DLC, the diagnostic tool should automatically turn on. If the tool did not turn on when the data cable was connected to the vehicle, check the vehicle DLC for power. Most OBD-II vehicles supply power to the DLC, which in-turn supplies power and turns on the diagnostic tool when the cable is connected.
5. If required, turn the diagnostic tool on.
6. Depending on the vehicle:
 - a. Instant ID may occur, as indicated by an audible "beep" approximately 6 seconds after boot-up. Select the **Scanner** icon, then wait for the vehicle confirmation screen ([Figure 5-3](#)) and select **OK** to continue. Then proceed to **step 6**. See [Instant ID](#) on page 16, for additional information about this function.

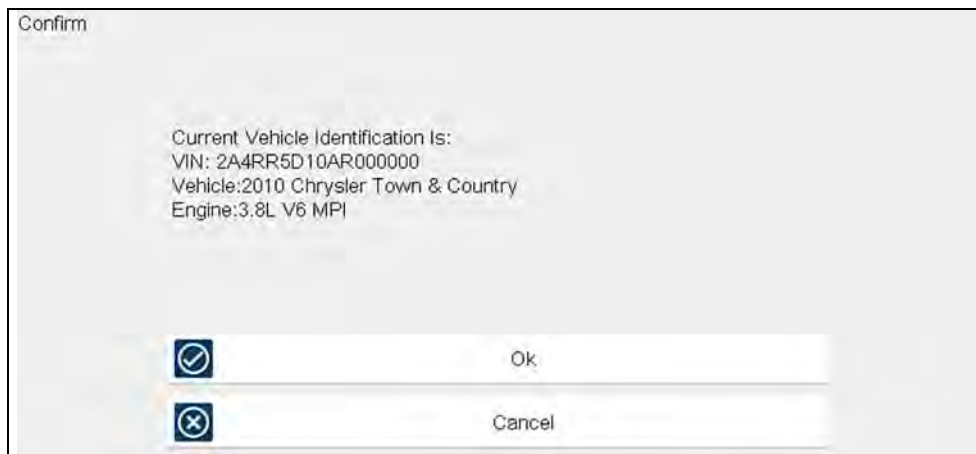

Figure 5-3 Vehicle confirmation screen

b. If Instant ID is not supported, you will be prompted to select the vehicle make and year (If needed). Then a menu option is displayed to choose either **Automatic ID** or **Manual ID**.

- Selecting **Automatic ID** (If supported by the vehicle) will briefly display a communications screen informing you that the diagnostic tool is attempting to establish communication with the vehicle and determine vehicle identification.

Once the vehicle has been identified, the vehicle confirmation screen displays. If the vehicle information is correct, select **OK** to continue, then proceed to step 6.

If the vehicle does not support Auto ID, the diagnostic tool will attempt to identify the vehicle and then display a message indicating that vehicle identification cannot be made. If this occurs, proceed to “**Selecting Manual ID**” next.

- **Selecting Manual ID** allows you to manually enter all the vehicle information to identify the vehicle.

b1.) Follow the screen prompts to enter all the information required to identify the vehicle.

b2.) Once the vehicle has been identified, the vehicle confirmation screen displays (*Figure 5-3*). If the vehicle information is correct, select **OK** to continue, then proceed to step 6.

7. After the vehicle is identified, a menu of available systems and/or options are displayed, see *System Selection* on page 17.

Instant ID

The Instant ID function, can save time when initially identifying a vehicle, by automatically communicating with the vehicle to complete the vehicle identification process.

This function requires specific vehicle support requirements, and connection procedures to operate.

- **Vehicle requirements:**
 - Vehicle must support Mode \$09 VIN.
 - **Note:** *Mode \$09 VIN is mandated on 2008 and newer vehicles.*
 - Vehicle must be equipped with Hi Speed CAN or J1850 communication protocol.
- **Connection procedure requirements:**
 - 1.) Turn the vehicle ignition on.
 - 2.) Connect the data cable to the diagnostic tool.
 - 3.) Connect the data cable to the vehicle data link connector (DLC).
 - 4.) The diagnostic tool should turn on automatically. If required, turn the diagnostic tool on.

An audible "beep" will sound approximately 6 seconds after boot-up, if the VIN is read.

Note: *No visual confirmation is displayed.*
 - 5.) Select **Scanner**.

When Scanner is selected, a screen may briefly appear informing you the diagnostic tool is attempting to automatically complete the vehicle identification process.
 - 6.) After the vehicle has been identified, the vehicle confirmation screen displays. If the vehicle information is correct, select **OK** to continue.

i NOTE

Depending on the vehicle, Instant ID may occur automatically and only ask you to confirm the vehicle, or additional screen prompts may be displayed to enter vehicle information.

NOTE

If the Scanner feature is exited during the session that Instant ID was used, selecting Scanner again, will not ID the vehicle again. To quickly ID the vehicle again, select it from **Previous Vehicles and Data > Vehicle History**.

If the vehicle is not automatically identified, follow the screen prompts to enter the information required to identify the vehicle.

Alternative Vehicle Identification

Occasionally, you may try to identify a test vehicle that the Scanner does not recognize, the database does not support, or has some unique characteristics that prevents it from communicating with the Scanner. In these instances, there is an alternate choice that allows you to establish communication with the vehicle:

- **OBDII/EOBD Function**—this function allows you to connect to the OBDII equipped vehicle and perform basic OBD-II or EOBD diagnostic functions, see [OBD Direct](#) on page 62 for additional information.

5.2.5 System Selection

After the vehicle is identified, a menu of available systems and/or options is displayed ([Figure 5-4](#)).

By default, System options are displayed by category (e.g. Engine, Transmission, Body Controls, Instruments, etc.) ([Figure 5-4](#)). In this mode commonly used selections are at the top of the list.

Depending on your preference, select the icon (*arrow in [Figure 5-4](#)*) to toggle the display between a categorized list ([Figure 5-4](#)) and a non-categorized list ([Figure 5-5](#)).

When a system (e.g. Engine, Antilock Brakes, etc) is selected, the diagnostic tool will attempt to establish communication with that vehicle system, then (once connected) will display that system's main menu, see [System Main Menu Options](#) on page 18.

NOTE

Only the systems and options supported for the vehicle are included in the list(s).

For Code Scan information, see [Vehicle Code Scan](#) on page 40.

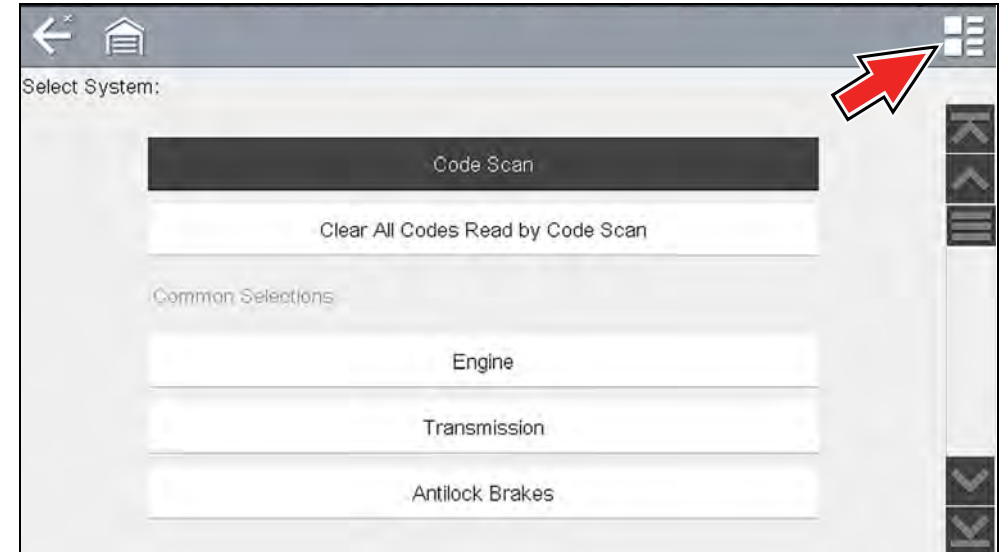

Figure 5-4 Typical systems menu (categorized list)

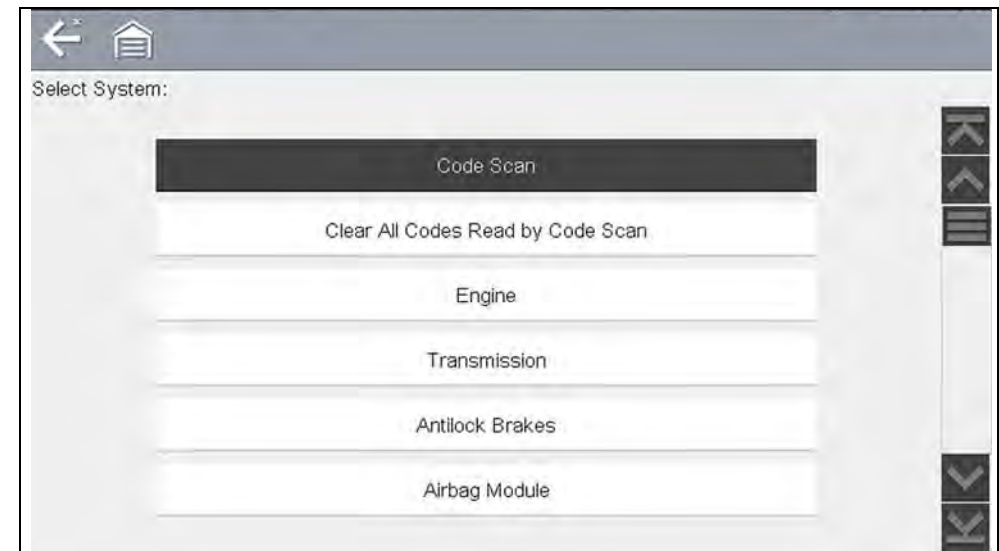

Figure 5-5 Typical systems menu (non-categorized list)

5.2.6 System Main Menu Options

Once a System (e.g. Engine, Transmission, Antilock Brakes, etc) is selected, the available options for that system are displayed ([Figure 5-4](#)).

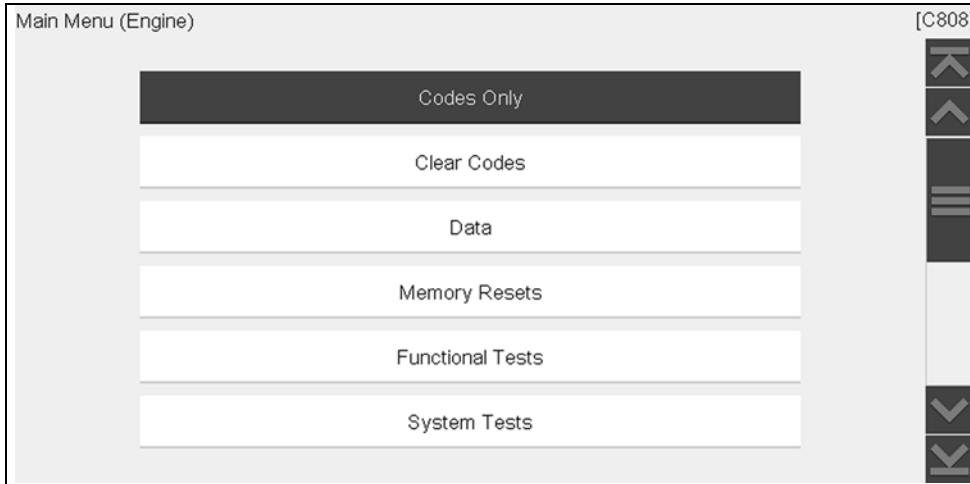

Figure 5-6 Typical Engine Systems List

NOTE

Menus and navigation will vary by vehicle.

The System Main Menu may include:

- **Codes Menu**—displays diagnostic trouble code (DTC) records from the vehicle electronic control module. Selecting may open a submenu of viewing options.
- **Clear Codes**—erases DTC records and other data from the ECM. This selection is found on a Codes submenu for some models.
- **Data Display**— displays PID data from the vehicle electronic control module. Selecting may open a submenu of viewing options.
- **Functional Tests**—provides specific subsystem tests. The tests vary depending on the manufacturer and model.
- **Actuator Tests**—similar to functional tests, checks the operation of certain actuators, such as solenoid valves and relays.
- **Memory Resets**—allows you to reprogram adaptive values for certain components after making repairs. Selecting opens a submenu. These options are found on the Functional Tests Menu for some models.

- **System Tests**—provides specific subsystem testing. Performing these tests is similar to functional tests.
- **Generic Functions**—lets you access certain available Generic OBD II functions from a proprietary menu (1996 and newer vehicles only).
- **Troubleshooter**—provides step-by-step procedures, integrating PIDs and retrieving trouble codes when appropriate, for specific symptoms of the identified vehicle.

The following sections, describe some of the System Main Menu items listed above.

5.3 Codes - View / Save

5.3.1 Codes Menu

After selecting a System, this selection “Codes Menu” may appear as a different name (e.g Codes, Codes Menu, Codes Only, Codes (No Data), Service Codes) or something similar depending on the vehicle manufacturer. Options may include:

- [Display Codes](#)
- [Clear Codes](#) on page 19
- [Freeze Frame/Failure Records](#) on page 20

The following Code related control icons are used:

Icon	Function
	Diagnose - Opens Intelligent Diagnostics for the code selected (highlighted)
	Save - Saves the displayed code list results as an (.XML) file. See Viewing Codes and Code Scan Results on page 113.
	Help - The Help icon on the toolbar opens the Getting Started with Intelligent Diagnostics slideshow. See Getting Started (Demonstration) on page 46.

Display Codes

This function opens either a list of diagnostic trouble codes (DTCs) stored in the selected vehicle electronic control module (ECM), or a submenu of DTC viewing options. The code list includes the DTC and a brief description (*Figure 5-7*).

If Intelligent Diagnostics information (optional) is active and data is available for a selected DTC, the Diagnose icon (*Figure 5-7* arrow) is selectable. For additional information about using Intelligent Diagnostics, see *Intelligent Diagnostics* on page 45.

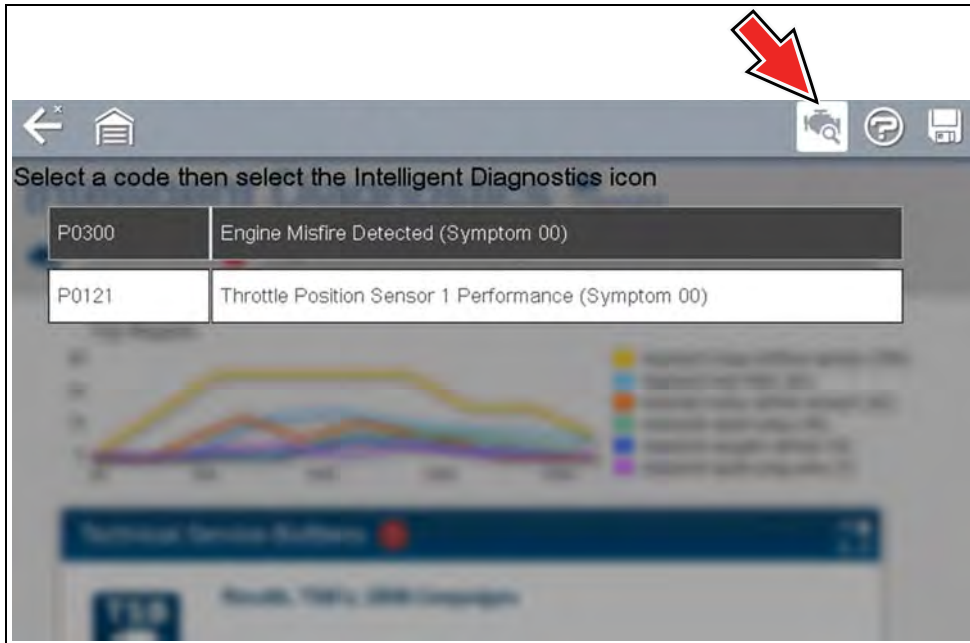

Figure 5-7 DTC results and Diagnose icon

Submenu options may include:

- **Trouble Code Information**—opens a list of codes in ECM memory
- **History Codes**—opens a list of codes whose symptoms are not currently present. History codes indicate an intermittently occurring problem.
- **Failed This Ignition**—opens a list of codes that set during the current ignition cycle.
- **MIL SVS or Message Requested**—displays ECM requests to turn on the malfunction indicator lamp (MIL) or service vehicle soon (SVS) lamp, or display a driver information alert.

- **Last Test Failed**—displays a complete list of failed tests.
- **Test Failed Since Code Cleared**—displays a list of tests that failed since the last time codes were cleared from ECM memory.

Clear Codes

The diagnostic tool clears codes from the vehicle electronic control module memory on most vehicles. If this function is not available on the test vehicle, Clear Codes does not appear as a menu option.



To clear codes:

1. Select **Clear Codes** from the Codes Menu.
A confirmation message displays.
2. Make sure any conditions shown on the confirmation message are met, then select **Yes**.
A “codes cleared” message displays once the operation is complete.
3. Select **Continue** to return to the Codes Menu.

IMPORTANT

Clearing codes erases all temporary ECM information, including Freeze Frame/Failure Records. Make sure no vital diagnostic information will be lost before clearing codes.

Freeze Frame/Failure Records

Selecting **Freeze Frame/Failure Records**, displays the DTC that was set.

Then when the Freeze Frame icon ([Figure 5-8](#)) is selected, the corresponding Freeze Frame data that was captured when the ECM commanded the malfunction indicator lamp (MIL) to turn on, is displayed.

SureTrack (if activated) repair information may be available for the selected code. Select the **Fix It!** icon on the toolbar to display the information.

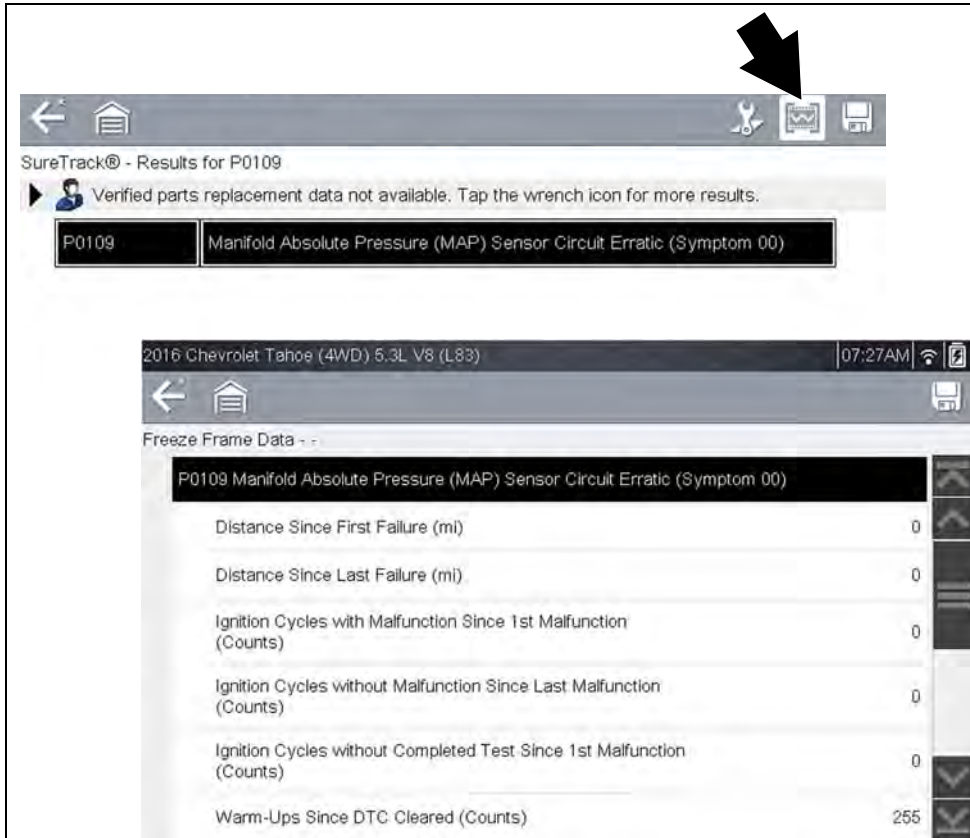

Figure 5-8

5.3.2 Code Scan (with Vehicle System Report)

Code Scan is available from the Vehicle System menu, and when selected it scans the vehicle control modules for codes. For detailed information see [Vehicle Code Scan](#) on page 40.

5.4 Viewing and Saving Data (PIDs)

Data - Topic Links

- [Data Menu](#) page 20
- [Custom Data List \(PID List\)](#) page 22
- [Custom PID list \(cross-system\)](#) page 24
- [Changing Data Views \(List / Graph\)](#) page 27
- [Locking PIDs \(to always display at top\)](#) page 28
- [About the Data Buffer](#) page 28
- [About Cursors](#) page 29
- [Pausing and Reviewing Active Data](#) page 30
- [Saving Data Files](#) page 31
- [Using Zoom](#) page 33
- [Using Triggers](#) page 33

5.4.1 Data Menu

Selecting **Data** or another similar data menu option (e.g. Data Display) from a vehicle's system main menu (depending on the vehicle manufacturer) displays the Data menu ([Figure 5-9](#)). The Data menu displays the available PID lists based on the selected vehicle system.

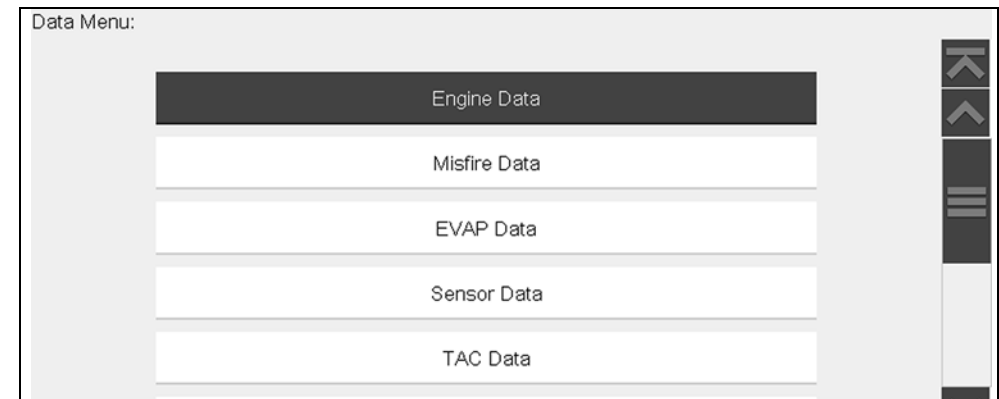

Figure 5-9 Typical - Data Menu

- To display the next data list (if applicable), select the **Right Arrow** icon ([Figure 5-10](#)).

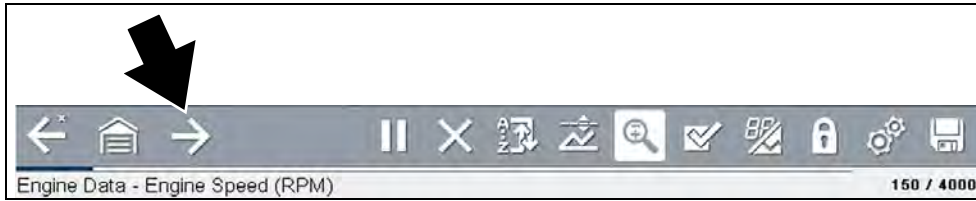

Figure 5-10

There are 2 basic PID list types:

- [All System Data](#)
- [Related System Data](#)

All System Data

All System Data PID lists (if supported) display all available PIDs for that system. In the example shown in [Figure 5-11](#), from within an Engine system Data menu, the **Engine Data** option can be used to display all Engine related PIDs. Typically this option is named the same as the system (e.g. Engine System = Engine Data, Transmission System = Transmission Data, etc)

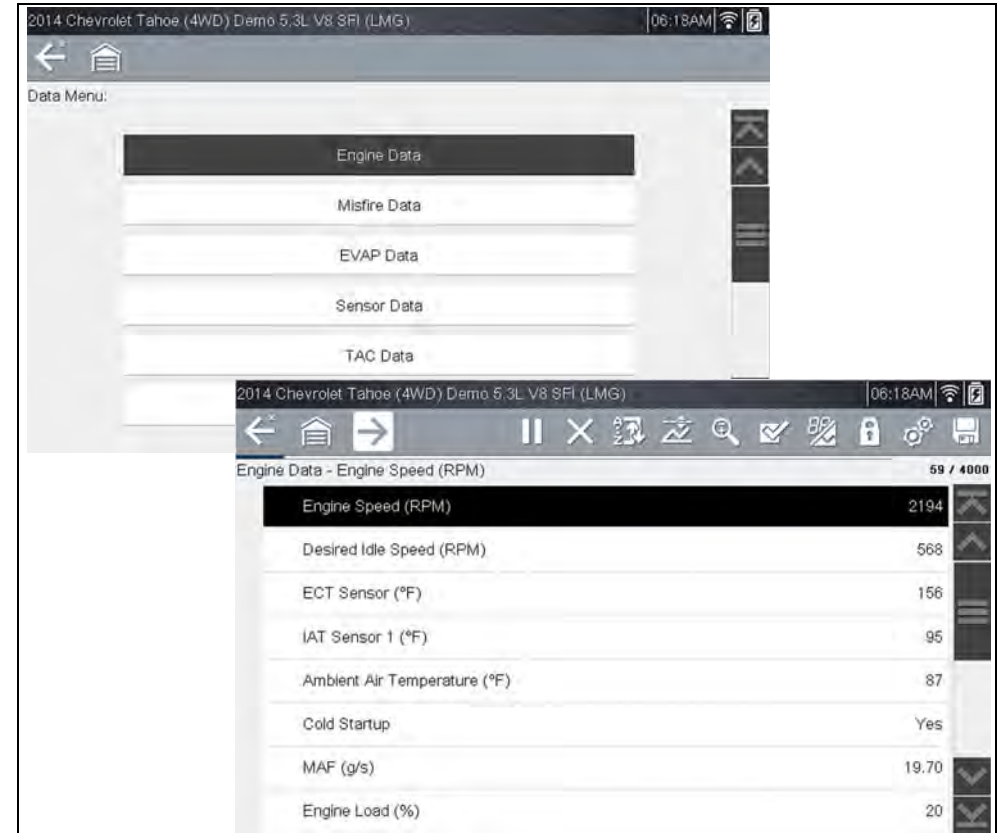

Figure 5-11

Related System Data

Related System Data PID lists (if supported) display a unique list of PIDs that are related to the primary system (e.g. Misfire, EVAP, and Fuel Trim PID lists are related to the Engine system). These special PID lists are basically custom PID lists that can save you time by allowing you to view a related set of PIDs when trying to isolate a problem. [Figure 5-12](#) illustrates the selection of “Misfire Data” (upper image) from within an Engine system and the typical “Misfire Data” PID results (lower image).

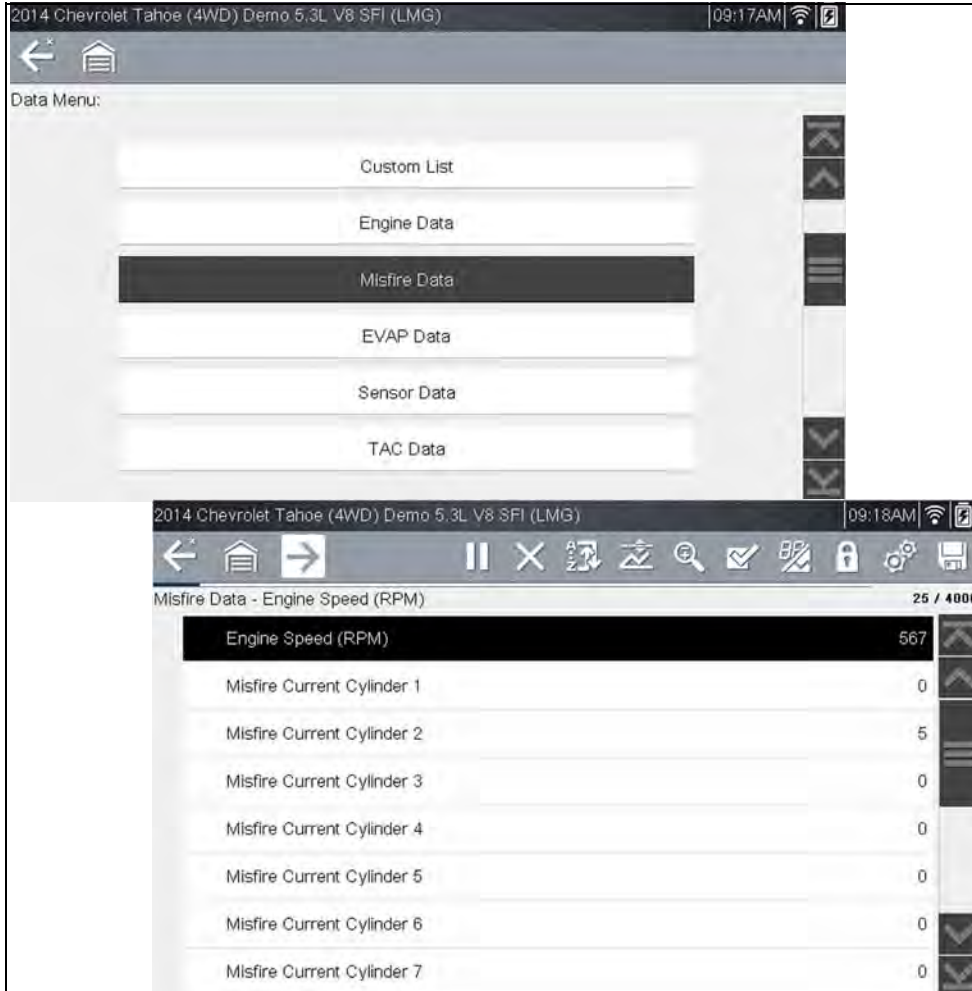

Figure 5-12

Custom Data List (PID List)



The **Custom Data List** icon on the toolbar is used to select which PIDs to display. Minimizing the number of PIDs displayed allows you to focus on any suspicious or symptom-specific data parameters. You can add or remove most PIDs from the list, as certain vital PIDs may not be removed. These appear in gray at the top of the list along with a lock icon, and they cannot be selected.

NOTE

Limiting the number of parameters that display to those that apply to a particular situation results in a faster data refresh rate, and reduces the amount of memory used for saved files. Limiting the parameters also allows you to focus on any suspicious or symptom-specific data parameters.



To create a custom data list:

1. Select the **Custom Data List** icon on the toolbar ([Figure 5-13](#)).

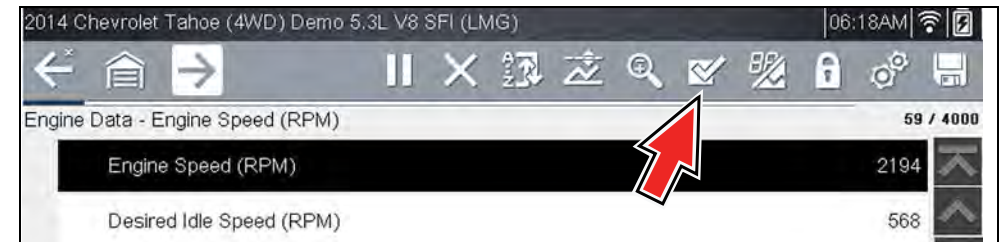

Figure 5-13

The data selection screen displays (Figure 5-14). Check marks to the left of the parameter description indicate which parameters are selected for display.

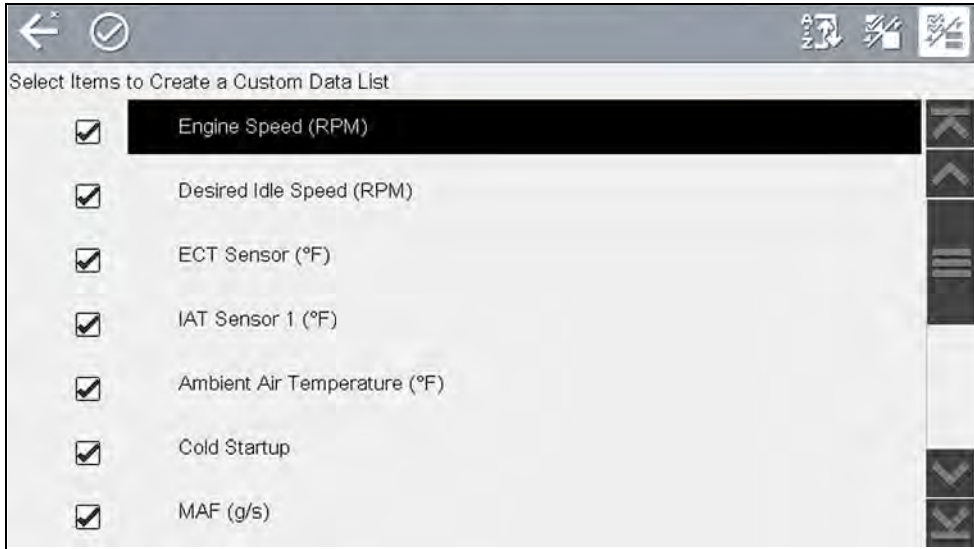

Figure 5-14

The toolbar icons provide options for sorting, selecting and deselecting parameters to include or remove from the custom data list:

Icon	Description
	Sort - Determines the order in which PIDs are listed on the screen.
	Select/Deselect - hide or display individual PIDs in the list
	Select All/Deselect All - hide or display all PIDs in the list.

2. Create a custom data list by selecting (check mark) the parameters to include (Figure 5-15).

3. To create and view the custom list, select the **Accept** icon (Figure 5-15).

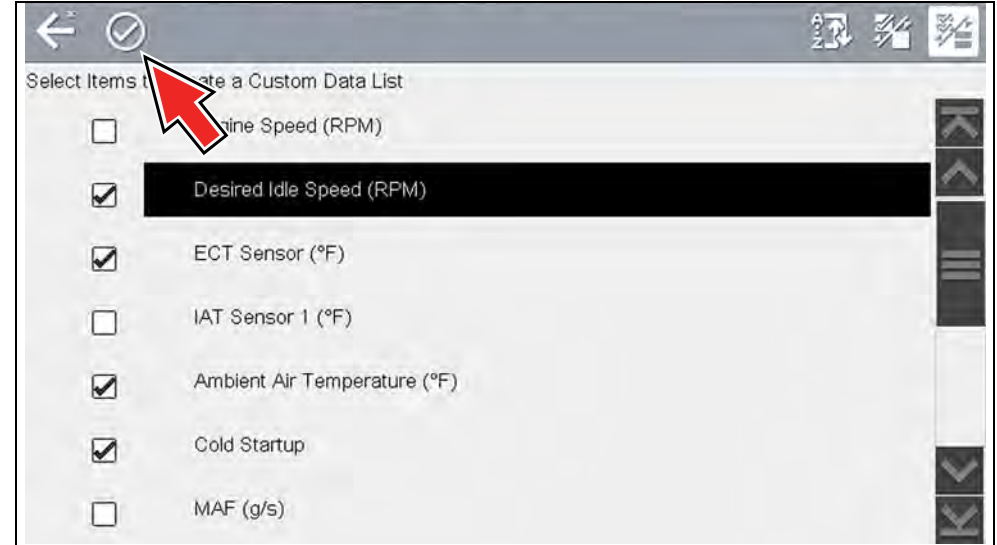

Figure 5-15

4. The custom list displays (Figure 5-16).



Figure 5-16

NOTE

From the Custom Data list, if you select **Back** to display the Data Menu list, your new Custom List shows as a selectable option at the top of the list (Figure 5-17). This Custom List option will only remain an option as long as you are in the Data Menu. This allows you to view other data lists and return to your Custom List, however, if you back out to the Main Menu, and then return to the Data Menu your Custom List is deleted.

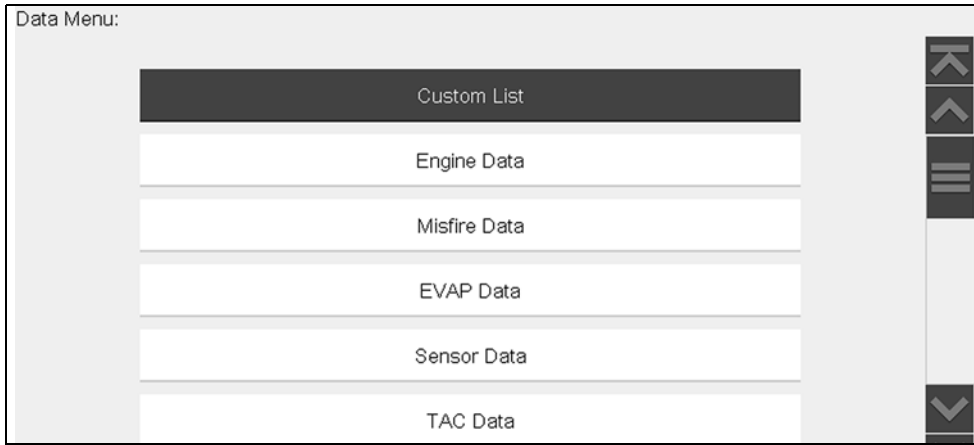

Figure 5-17

Custom PID list (cross-system)

Some vehicles may support a cross-system custom PID list, which allows you to choose multiple PIDs from across available systems to create a custom list.

Selecting a cross-system custom PID list is similar to selecting a standard custom PID list, however you have the option to select PIDs from multiple lists. See [Custom Data List \(PID List\)](#) on page 22 for basic operation instructions.

At the time of this publication, only select CAN integrated 2005 and later Mercedes-Benz®, Jaguar®, Chrysler®, Volkswagen® and Audi® vehicles support this feature. As future diagnostic software updates occur, additional vehicle makes and models may be included.

NOTE

The total number of PIDs that can be custom selected is limited, and varies by vehicle make and model.

NOTE

Limiting the number of parameters that display to those that apply to a particular situation results in a faster data refresh rate, and reduces the amount of memory used for saved files. Limiting the parameters also allows you to focus on any suspicious or symptom-specific data parameters.

**To create a Cross-System custom data list:**

1. From the Data Menu select the **Custom List** icon on the toolbar (Figure 5-18). The Custom List icon allows you to start a custom list directly from the Data Menu.

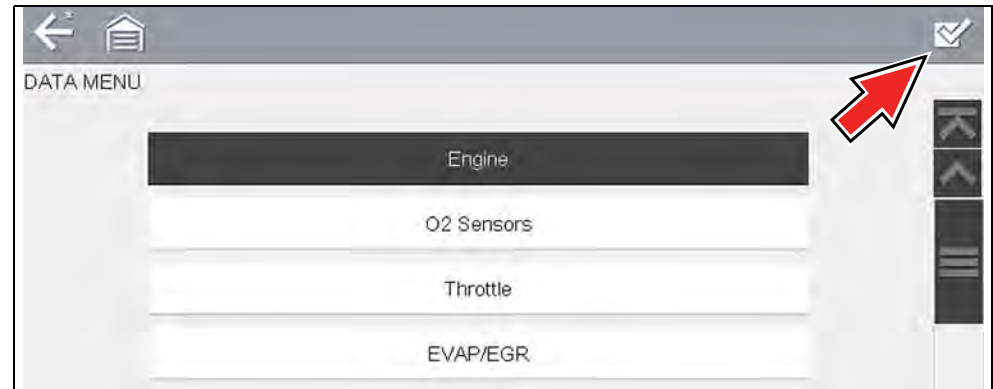

Figure 5-18

2. The data selection screen displays (*Figure 5-19*). Each list item is expandable, by selecting its Expand icon (*Figure 5-19*). You can expand any item from the list and select which PIDs you want to include, and then collapse the list and choose another if desired. The check marks to the left of the parameter description indicate which parameters are selected for display.

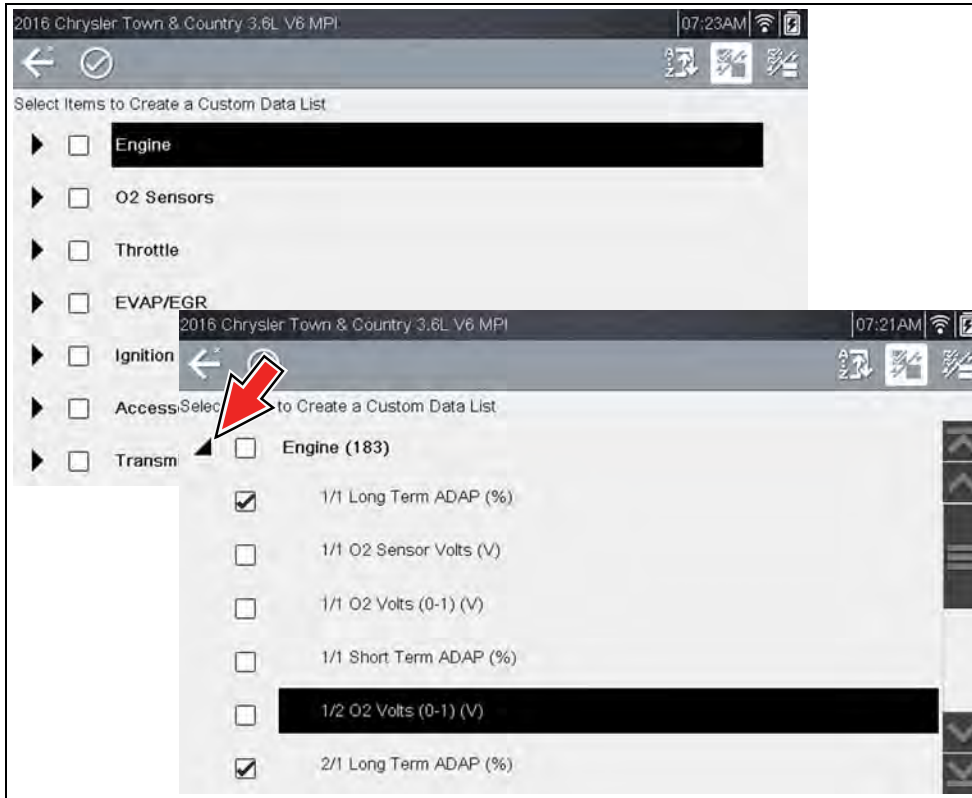

Figure 5-19

3. Once you have selected all the PIDs you need (*Figure 5-20*), to view the custom list, select the **Accept** icon (*Figure 5-20*).

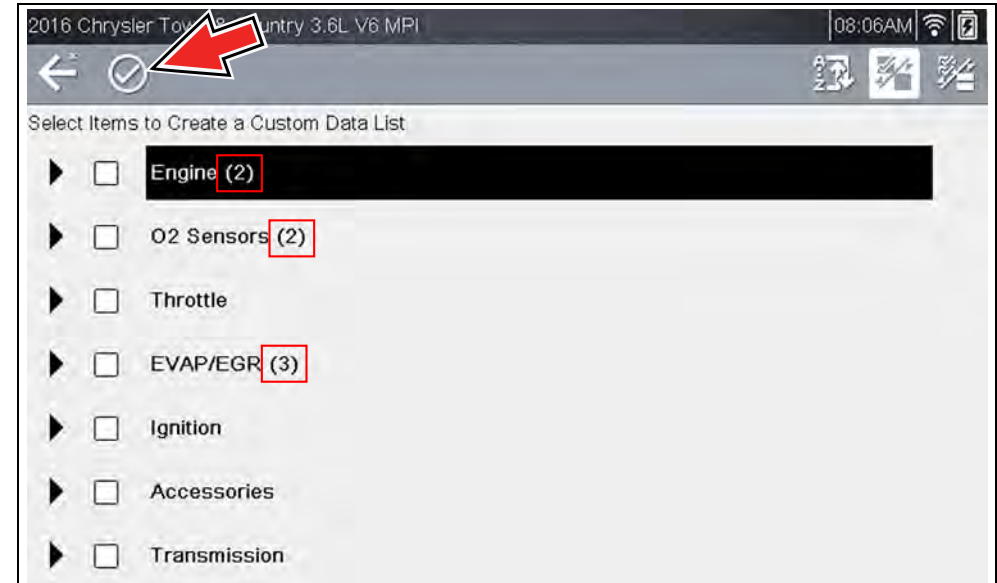

Figure 5-20

4. The custom list displays (*Figure 5-21*).

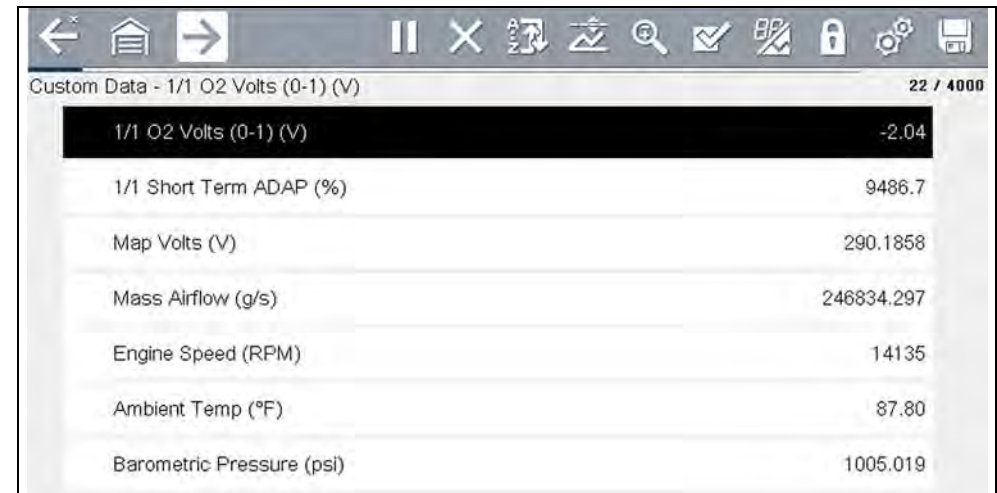

Figure 5-21

NOTE

From the Custom Data list, if you select **Back** to display the Data Menu list, your new Custom List shows as a selectable option at the top of the list (Figure 5-22). This Custom List option will only remain an option as long as you are in the Data Menu. This allows you to view other data lists and return to your Custom List, however, if you back out to the Main Menu, and then return to the Data Menu your Custom List is deleted.

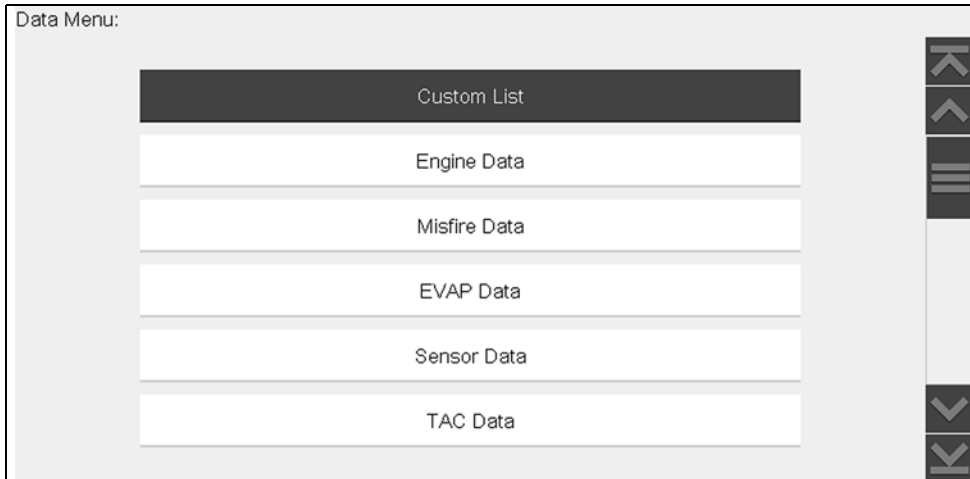

Figure 5-22

5.4.2 Data Views (List / Graph)

A typical **Data** screen is shown in Figure 5-23. This example shows a PID list view. A PID list screen is divided into two columns; the left-hand column has a description of the parameter and the right-hand column shows the current parameter value or state. PIDs are listed in the order in which they are transmitted by the ECM, so variations between years, makes, and models will occur.

Data can also be viewed in graph view (Figure 5-24), see [Changing Data Views \(List / Graph\)](#) on page 27.

The toolbar control icons are described in [Scanner Control Icons](#) on page 14 and [Common Toolbar Control Icons](#) on page 8.

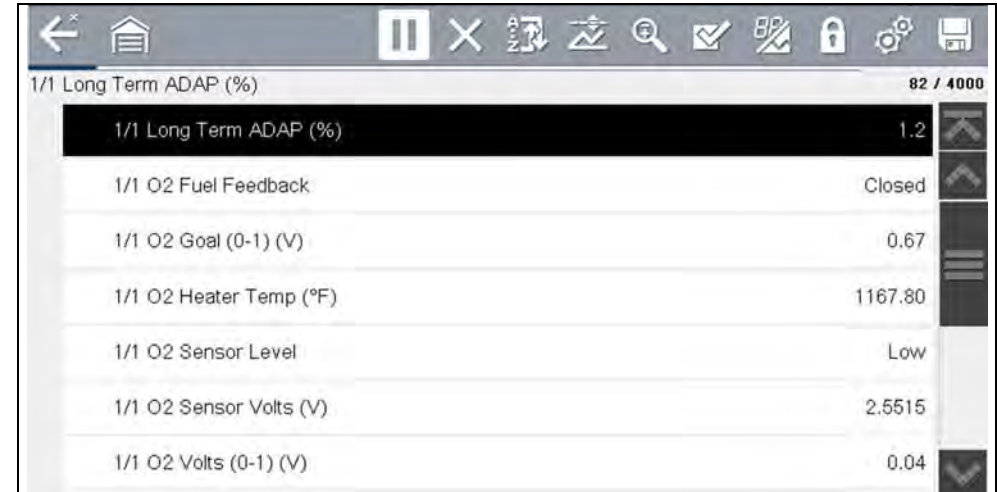

Figure 5-23 Data display (Typical - PID List view)

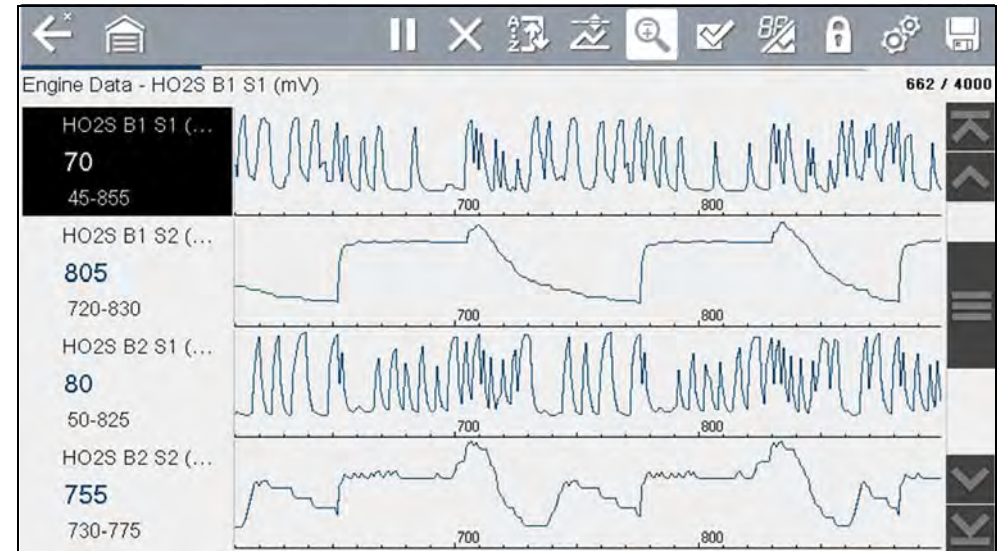

Figure 5-24 Data display (Typical - Graph view)

Changing Data Views (List / Graph)



Selecting the **View** icon ([Figure 5-25](#)) opens a drop-down menu of viewing options:

- PID List
- 1 Graph
- 2 Graphs
- 4 Graphs

The PID List view is a 2-column display with the name of the parameters in the left column and their current values in the right column ([Figure 5-25](#)).

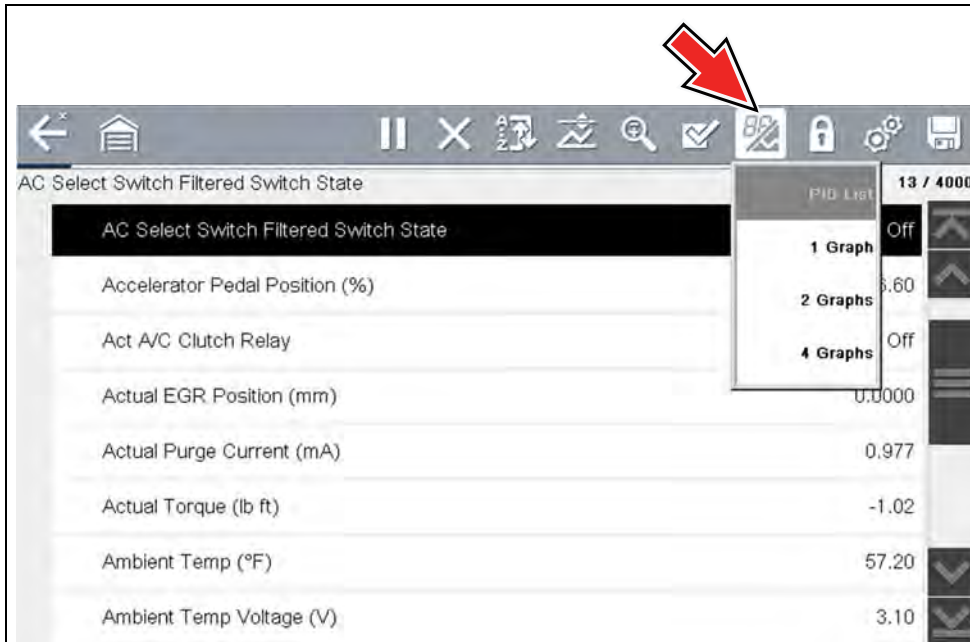

Figure 5-25 PID List view

The 1, 2, and 4 Graph views divide the screen horizontally to simultaneously display data graphs for the indicated number of parameters ([Figure 5-26](#)).

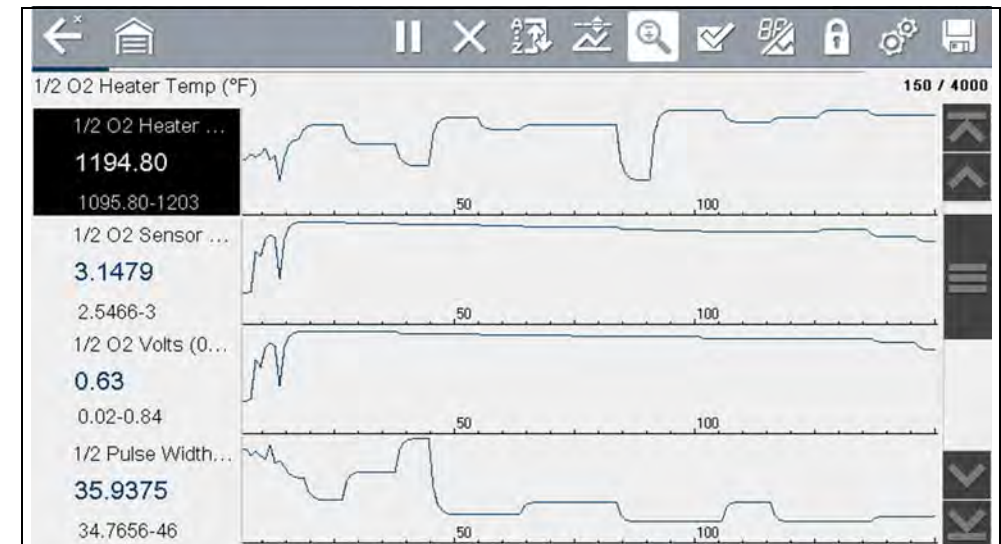

Figure 5-26 Four graph view

In graph view the text block ([Figure 5-27](#)) to the left of the graph displays:

- Top - PID description
- Middle - Current value or state
- Bottom - Active minimum and maximum values

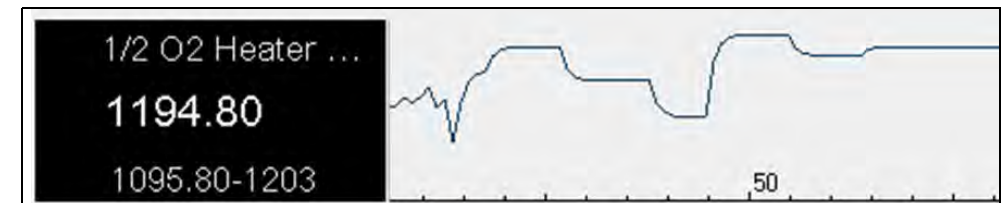

Figure 5-27

5.4.3 Locking PIDs (to always display at top)



Use the **Lock/Unlock** icon to hold selected lines of the data in place and prevent them from scrolling, or to release previously locked lines of data. Up to three lines of data may be held at a time. This feature allows you to position related parameters together, making it easier to monitor their values and spot inconsistencies.

Locked parameters display as the top frames on the main body of the display screen, as well as at their usual position within the data list ([Figure 5-28](#)). A lock icon appears to the left of the parameter name to indicate it is locked.



To lock parameters:

1. Highlight the parameter to be locked.
2. Select the **Lock/Unlock** icon on the toolbar to lock it.

A copy of the locked parameter is now shown at the top of the data list, and a lock icon appears alongside the parameter name.

3. Highlight and select additional parameters to lock.

Up to three parameters can be locked at a time. Once locked, a parameter remains locked until it is manually unlocked, or communication with the vehicle is stopped.

1/1 Long Term ADAP (%)		147 / 4000
	1/1 Long Term ADAP (%)	4.3
	1/1 O2 Heater Temp (°F)	1329.80
	1/1 O2 Sensor Level	High
	1/1 Long Term ADAP (%)	4.3
	1/1 O2 Fuel Feedback	Closed
	1/1 O2 Goal (0-1) (V)	0.35
	1/1 O2 Heater Temp (°F)	1329.80
	1/1 O2 Sensor Level	High

Figure 5-28 Locked parameters

NOTE

If three parameters are locked, one of them must first be unlocked before another parameter can be locked.



To unlock parameters:

1. Scroll through the data list and highlight the parameter to be unlocked, or released.
2. Select the **Lock/Unlock** icon on the toolbar.
The released parameter and the lock icon disappear from the list at the top of the data list.
3. Repeat Step 1 and Step 2 to release other parameters if needed.

5.4.4 About the Data Buffer

The diagnostic tool has the capability to collect, store and save PID data utilizing internal storage memory and buffer memory.

When Data is displayed onscreen, a data buffer automatically starts to store it in buffer memory. The data buffer runs continuously (storing data) until the Pause, Clear, or Save icon is selected.

Buffer memory is limited to a predetermined “total” size. When buffer memory reaches its full capacity, the data buffer will continue to store new data, however earlier stored data will be removed to allow room for the new data being stored.

The most recent data is always available for review when Pause is pressed, and can be reviewed using the toolbar controls.

The Data Buffer Indicator ([Figure 5-29](#) left arrow) can be used to visually see the amount of stored buffer data. This graphical indicator uses a bar graph to show how much stored data is in the memory buffer.



Figure 5-29

The Data Buffer Position Counter (*Figure 5-29* right arrow and *Figure 5-30*) indicates:

- first value = the numerical position of the active data point as displayed within buffer memory
- second value = indicates the maximum data buffer size value (e.g. 4000)

Figure 5-30 (right arrows) shows the relationship between the graph scale and the first value in the Position Counter.

During data review a slider on the bar graph (*Figure 5-30* left arrow), indicates the position of the current data point as displayed in relation to the entire memory buffer contents.

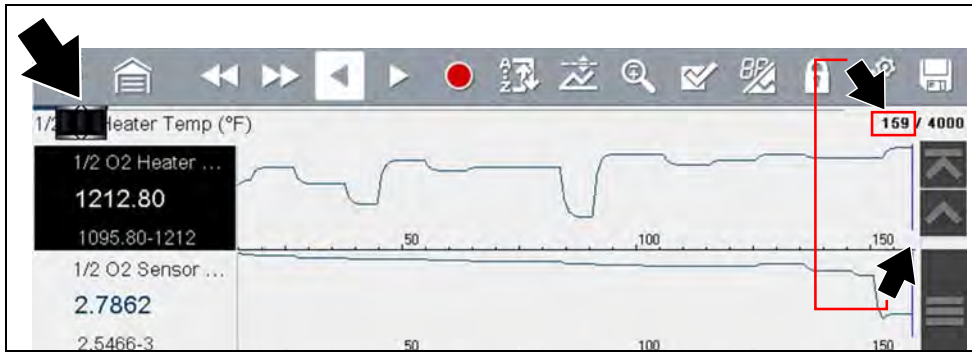

Figure 5-30

5.4.5 About Cursors

Vertical cursors are automatically displayed (in graphical PID views) to mark specific data reference points.

Gray (Pause/Save) - If you select Pause or Save while collecting data, a vertical gray cursor is automatically placed at that point in the data to indicate where the data was paused or saved.

- Each time Pause is pressed an additional cursor is added, and appears when Start is pressed to resume data collection.
- Each time Save is pressed an additional cursor is added, and appears when the data starts again after a slight pause to save the file.
- Cursors are displayed in all PIDs as reference markers.
- Cursors are retained and appear in saved data files.

Blue (Current Position) - If you select Pause while collecting data, a vertical blue cursor is displayed as an indicator to your position in the data and is denoted by the current position value in the counter display.

- Cursors are displayed in all PIDs as reference markers.
- Depending on the amount of data saved the blue cursor may be initially located on the far left next to the description, or the far right next to the scroll bar making it difficult to see. If this happens, use the control icons (Step/Skip) to move the data until you can see the cursor.

Red (Triggered PID Activation Point) - When using triggers, a vertical red cursor is displayed in the data of the triggered PID at the point where the trigger was activated.

- When multiple PIDs are armed, only the PID that is triggered first will display a red cursor.

Green (Trigger Activation Reference Point) - When using triggers, green vertical cursors are displayed in all PIDs (except the PID that was triggered) as reference to the triggered PID activation point.

- When a trigger is activated the displayed red and green cursors are all vertically aligned in the graphed data to show the relationship of the trigger point in all PIDs.

5.4.6 Pausing and Reviewing Active Data

During normal operation, data from the vehicle's ECM is continuously being stored in buffer memory as it is displayed onscreen. The Pause icon, allows you to temporarily pause data collection to review it in detail.



To pause and review active data:

While collecting data, select the **Pause** icon ([Figure 5-31](#)).

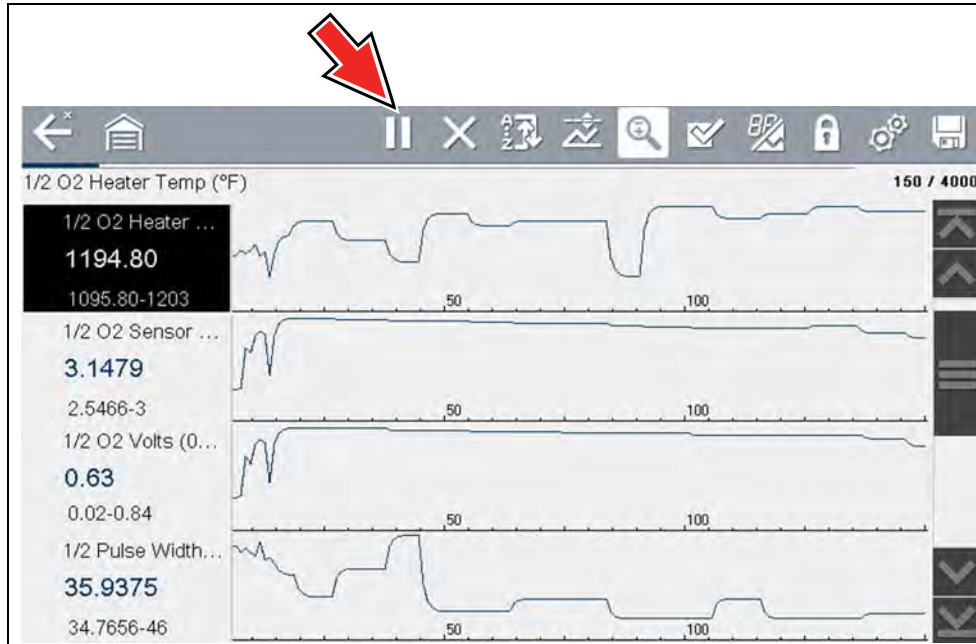

Figure 5-31

Toolbar control icons are described in [Scanner Control Icons](#) on page 14 and [Common Toolbar Control Icons](#) on page 8.

After Pause is pressed:

- Review control icons are displayed in the toolbar ([Figure 5-32](#)). Use the control icons to accurately move through the data and position the blue cursor.
- The blue (vertical cursor) ([Figure 5-32](#)) indicates your position in the data and is denoted by the current position value in the counter display. This cursor displays in all PIDs.

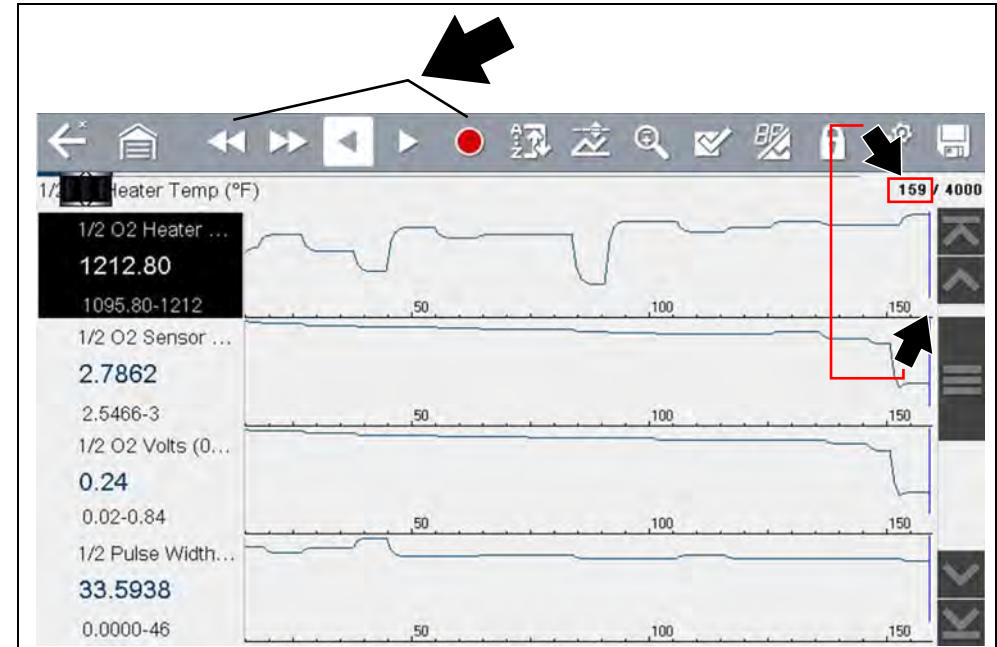



Figure 5-32

NOTE

The **Shortcut** icon can be set to perform the Pause/Play function. See [Configure Shortcut Button](#) on page 117 for additional information.

▶ To resume data collection (after pausing):

- Select the **Start** icon . The screen changes back to display data ([Figure 5-33](#)). A vertical gray cursor is displayed on all PIDs, indicating where the data was paused ([Figure 5-33](#)).

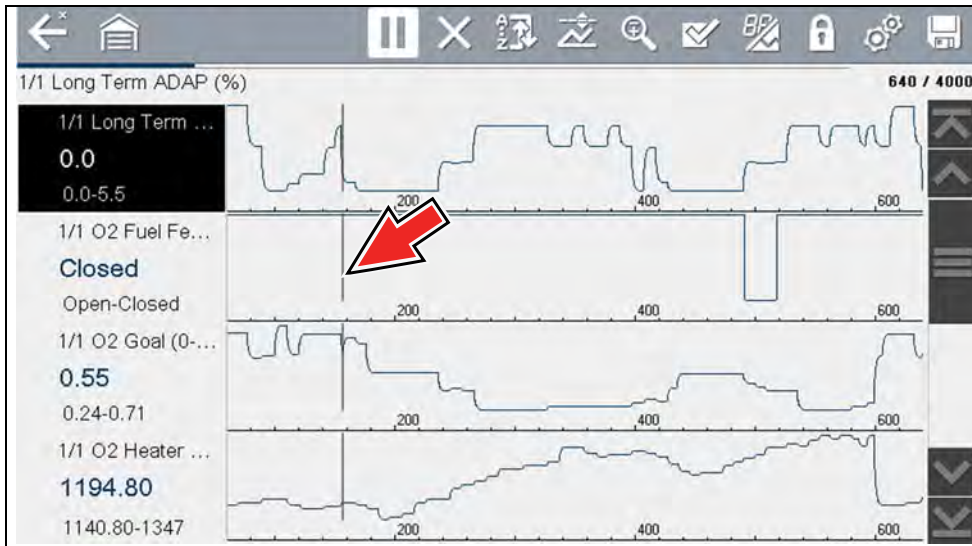

Figure 5-33

5.4.7 Saving Data Files

Saving data is useful when trying to isolate an intermittent problem or to verify a repair. During normal operation, data from the vehicle's ECM is continuously being stored in buffer memory as it is displayed onscreen. Selecting **Save** writes stored buffer memory to a file.

❗ NOTE

The **Save icon** performs the same function as “Save Movie” function choice for the programmable **Shortcut** button, see [Configure Shortcut Button](#) on page 117 for details.

▶ To save data:

While capturing or reviewing data, select the **Save** icon.

An onscreen message is displayed to indicate the data file is being saved ([Figure 5-34](#)).

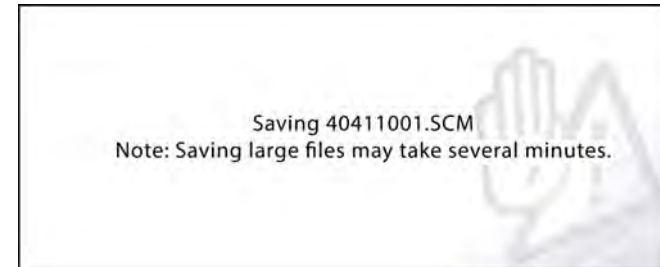

Figure 5-34 Save dialog box

▶ To view saved data (on the diagnostic tool):

The saved file can be viewed by selecting **Previous Vehicles and Data > View Saved Data**. See [View Saved Data](#) on page 113 for basic navigation.

1. Select the desired data file (.SCM file extension).
2. Change the view type and zoom levels as needed.
3. In graph view, use the control icons to move through the data ([Figure 5-35](#)).

Toolbar control icons are described in [Scanner Control Icons](#) on page 14 and [Common Toolbar Control Icons](#) on page 8.

The blue (vertical cursor) ([Figure 5-35](#)) indicates your position in the data and is denoted by the current position value ([Figure 5-35](#)) in the counter display. The cursor displays in all PIDs.



Depending on the amount of data saved the cursor may be initially located on the far left next to the description, or the far right next to the scroll bar making it difficult to see. If this happens, use the control icons to move the data until you can see the cursor.



Figure 5-35

Pressing the Save icon more than once in the same data collection session will create multiple (.SCM) files. Each file will contain gray (vertical cursors) ([Figure 5-35](#)) indicating where the data was paused.

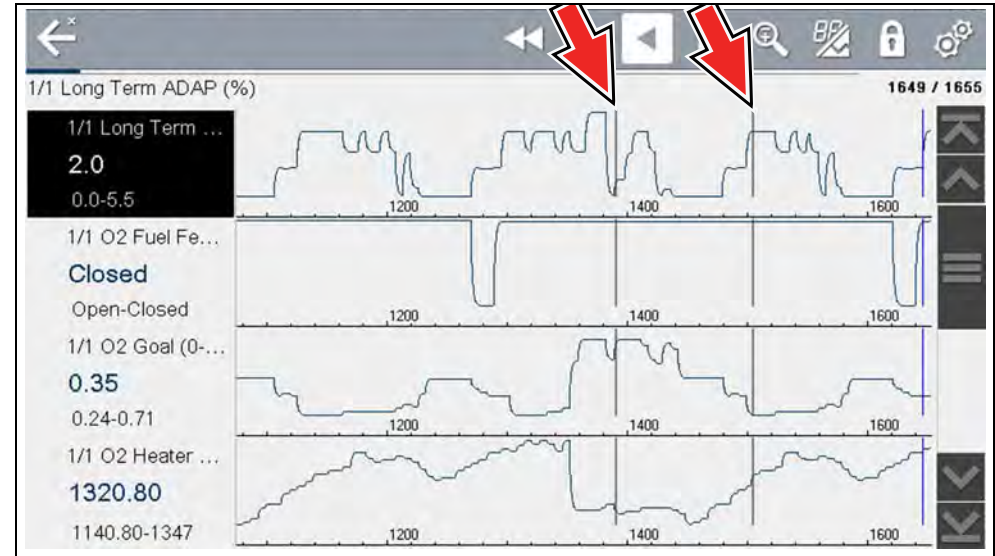

Figure 5-36

To view saved data (on a PC)

Saved data files can also be downloaded to a personal computer (PC) using the Mini USB jack. Once connected to the PC, the data files can be printed, transferred, and copied using ShopStream Connect. ShopStream Connect is an application that creates an interface between the diagnostic tool and a PC. The ShopStream Connect application is available free online, see [ShopStream Connect™](#) on page 144.



5.4.8 Using Zoom



The zoom function allows you to change the magnification level of the graphed data during data collection and review. Changing magnification levels allows you to compress or expand the displayed data to quickly find glitches, or signal losses.

When the **Zoom** icon is selected the dropdown menu allows you to select the display magnification level from a range of -2X to +8X. The "Zoom Out" option displays up to half of the maximum amount of data that can be collected, on one screen. The default magnification level is 1x.

Examples: Top (+4X), Middle (1X), Bottom (Zoom Out)



Figure 5-37 Zoom examples

5.4.9 Using Triggers

Trigger Description and Features



Setting PID triggers allows you to configure the diagnostic tool to automatically save PID data to a file, when a PID value meets an upper/lower limit (trigger point).

When a PID value meets the trigger point it activates the trigger which captures a short recording of all available PID data and saves it as a data file.

You can review the saved data file to closely evaluate not only the PID that triggered the event, but all the PIDs being monitored to collectively see what was happening at the time of the event.

Examples of the following trigger states (Armed / Not Activated - upper image) and (Activated - lower image) are shown in ([Figure 5-38](#)).

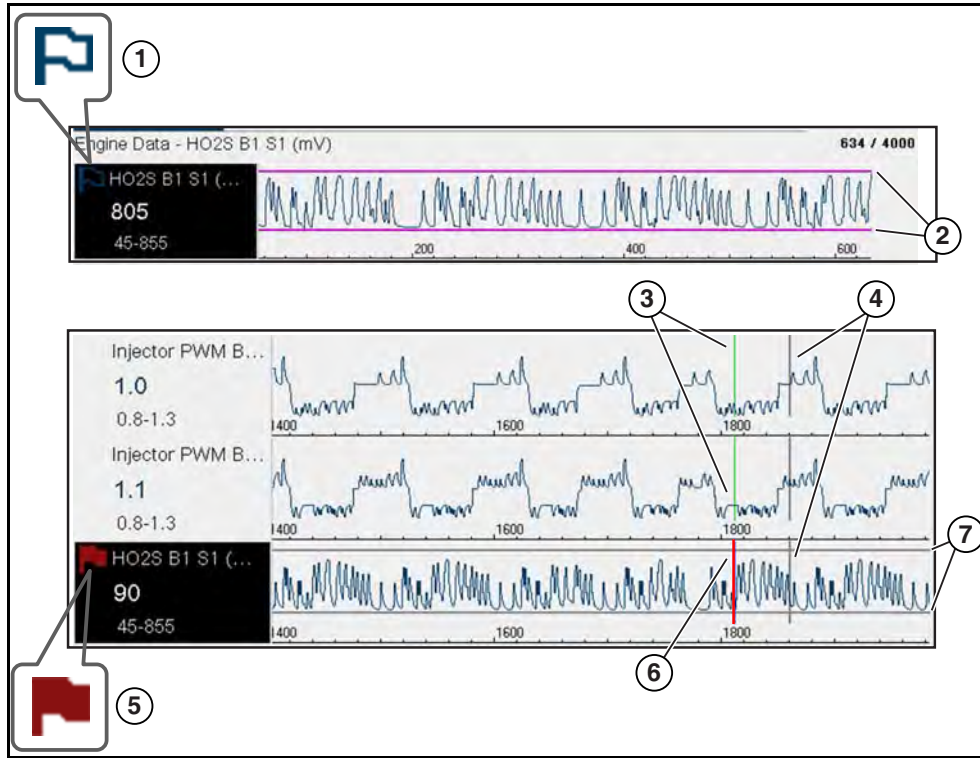



Figure 5-38

- 1— **Armed PID Trigger Indicator** - A blue outlined flag indicates the PID trigger is armed.
- 2— **Upper and Lower Limit Lines (Armed)** - Colored limit lines indicate the trigger is armed but not activated.
- 3— **Trigger Activation Point Reference Cursor** - Green cursors lines are displayed on all the other PID graphs to indicate their relationship to where the trigger occurred.
- 4— **Pause Cursor** - A vertical gray cursor line is displayed (all PIDs) as a marker in the where the data was paused and the file was saved.
- 5— **Activated PID Trigger Indicator** - A red flag indicates the PID trigger has activated.
- 6— **Trigger Activation Point Cursor** - A red cursor line is displayed in the PID data where the trigger was activated.
- 7— **Upper and Lower Limit Lines (Not Armed and Activated)** - Gray limit lines are displayed when the trigger is armed but not activated and after the trigger has been activated.

PID Trigger Status Icons

The icons (below) are used to help you quickly identify the status of individual PID triggers:

Icon	Description
	Trigger Armed Trigger has been set (configured) and is armed.
	Trigger Activated Trigger has been activated (upper or lower limit has been met).

▶ Setting triggers:

To use triggers, they must be turned on (set/configured), and then armed. Use the following procedures to setup PID triggers.

1. Highlight the PID to setup with a trigger.
2. Select the **Trigger** icon.

Selecting the **Trigger** icon ([Figure 5-39](#)) displays trigger menu options:

- **Set Trigger**—opens setup screen for upper/lower limits (trigger points)
- **Arm Trigger**—arms the trigger to capture data
- **Clear All Triggers**—deletes all previously set triggers

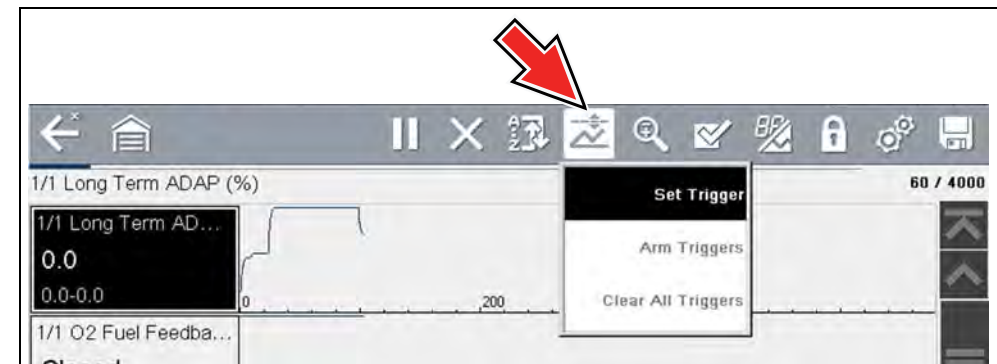

Figure 5-39 Trigger menu



If triggers are already set, the menu options are:

- **Clear Trigger**—deletes the highlighted trigger
- **Disarm Trigger**—disarms the highlighted trigger
- **Clear All Triggers**—deletes all set triggers

3. Select **Set Trigger**.

A graph of the highlighted PID and setup icons display (*Figure 5-40*).

The upper trigger point must be set first. A red horizontal line is displayed across the data graph (*Figure 5-40*) representing the upper trigger point.

4. Use the plus (+) and minus (-) icons (*Figure 5-40*), or the up ▲ and down ▼ arrow buttons to change the position of the upper trigger point.
5. Select ✓, or press the Y/✓ button, to set the upper trigger point.

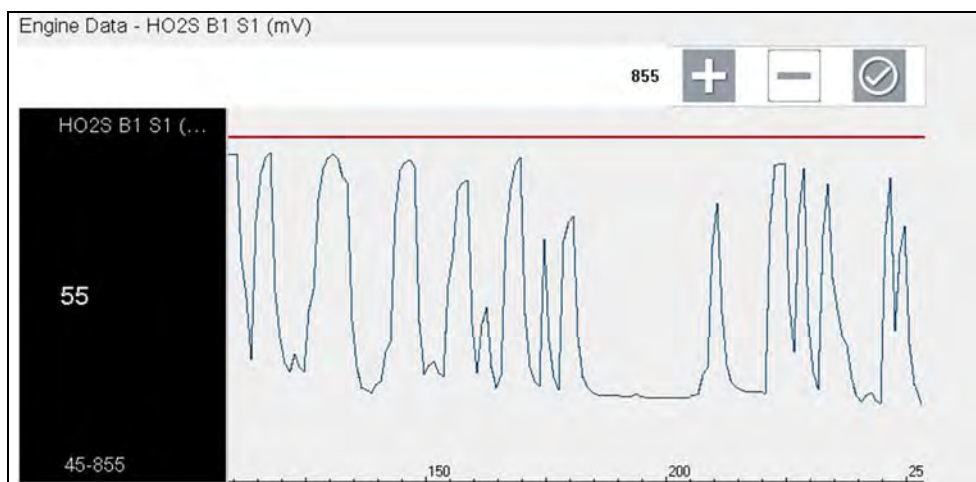

Figure 5-40 Trigger setup - upper limit

The upper trigger line changes color to gray and the lower trigger line displays in red (*Figure 5-41*).

6. Change the position of the lower trigger line in the same manner as the upper.
7. When finished, select ✓, or press the Y/✓ button, to set the lower trigger level.

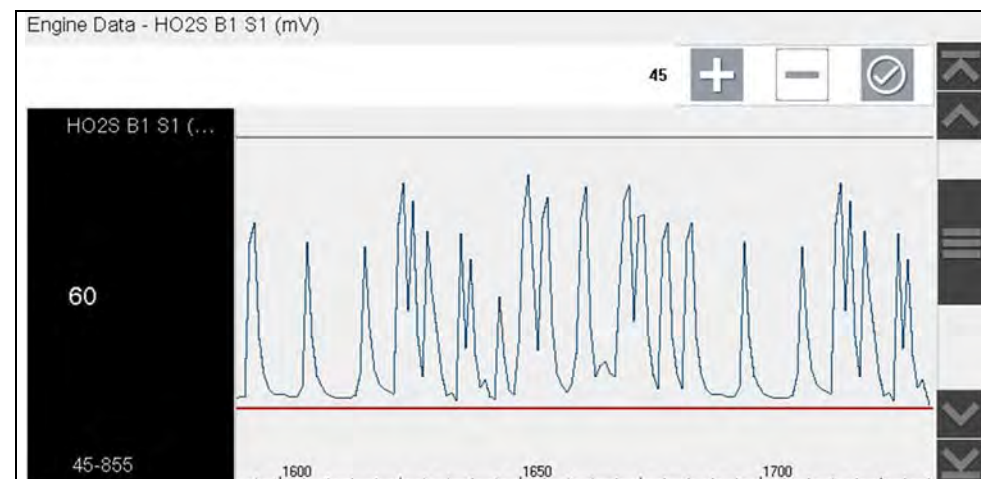

Figure 5-41 Trigger setup - lower limit

The display returns to the PID data view and the trigger points appear as horizontal lines across the designated graph (*Figure 5-42*). Repeat this procedure to establish trigger points for other parameters (up to three) if desired.

i NOTE

Only three parameters can have trigger levels set at one time, but only one of the conditions needs to be satisfied for triggering to occur.

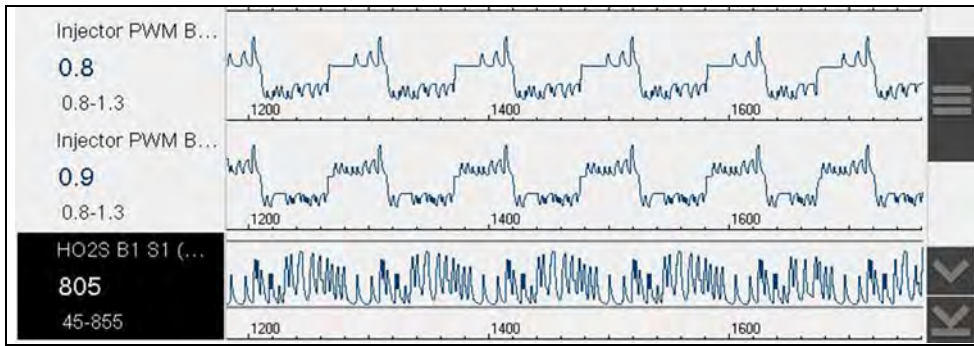

Figure 5-42 Trigger set (not armed)



Arming triggers:

1. Select the **Trigger** icon.
2. Select **Arm Triggers**.

The trigger point lines change color to indicate an armed condition (Figure 5-43).

All set PID triggers are armed simultaneously (if more than one is set). Once armed it remains armed until you clear it or the trigger is activated.

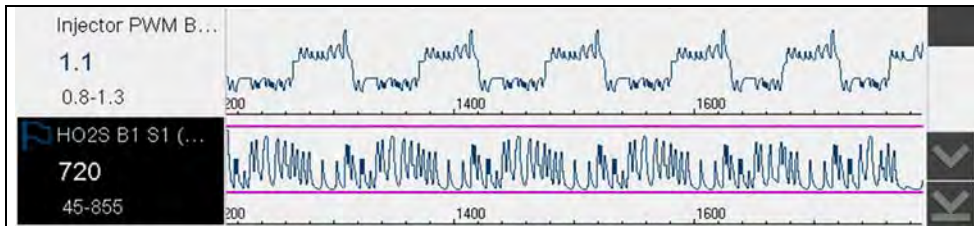

Figure 5-43 Trigger armed

About Activated Triggers

A trigger is activated (displays red flag)  when a PID value meets an upper/lower limit (trigger point).

When a trigger is activated:

- Data collection is briefly paused as the Scanner captures a recording of all available PID data, and saves it as a data file.
- A gray cursor line is displayed to indicate the point at which the data was paused or saved.
- An audible alarm is sounded
- A message displays indicating a data file was saved.
- Data collection continues.
- The activated PID trigger is disarmed. **Note** - if a different PID trigger is activated subsequently, an additional data file will be recorded.
- A red cursor line is displayed on the graph of the PID with the activated trigger to indicate where the trigger occurred. A green cursor line is displayed on all the other PID graphs to indicate their relationship to where the trigger occurred.

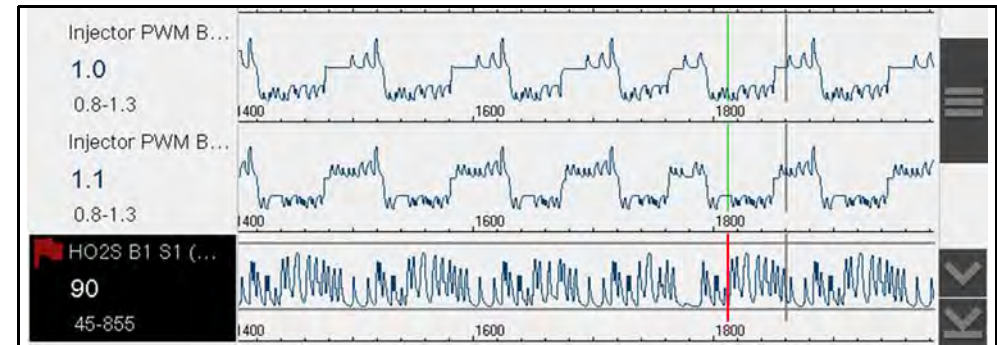

Figure 5-44 Trigger activated

5.5 Functional Tests

The **Functional Tests** selection is used to access vehicle-specific subsystem tests. Available tests vary by manufacturer, year, and model. Only the tests available for the identified vehicle display in the menu.

There are several types of functional tests:

- **Information Tests**—these are read-only tests, like selecting “VIN” from a Functional Tests menu to display the VIN of the identified vehicle.
- **Toggle Tests**—these tests switch a component, such as a solenoid, relay, or switch, between two operating states.
- **Variable Control Tests**—these tests command a certain value for a system or component, such as varying spark timing in 1° increments or EGR valve duty cycle in 10% increments.
- **Reset Tests**—these tests reset the adaptive, or learned, values that are stored in the vehicle electronic control module memory.
- **Scripted Tests**—these tests are software routines that place the vehicle into special operating modes for performing certain repairs, such as bleeding brakes with ABS.

Selecting Functional Tests opens a menu of test options that varies by make, year, and model. Selecting a menu option either activates the test or opens a submenu of additional choices. Follow all screen instructions while performing tests. How and what information is presented on the screen varies according to the type of test being performed and the vehicle being serviced.

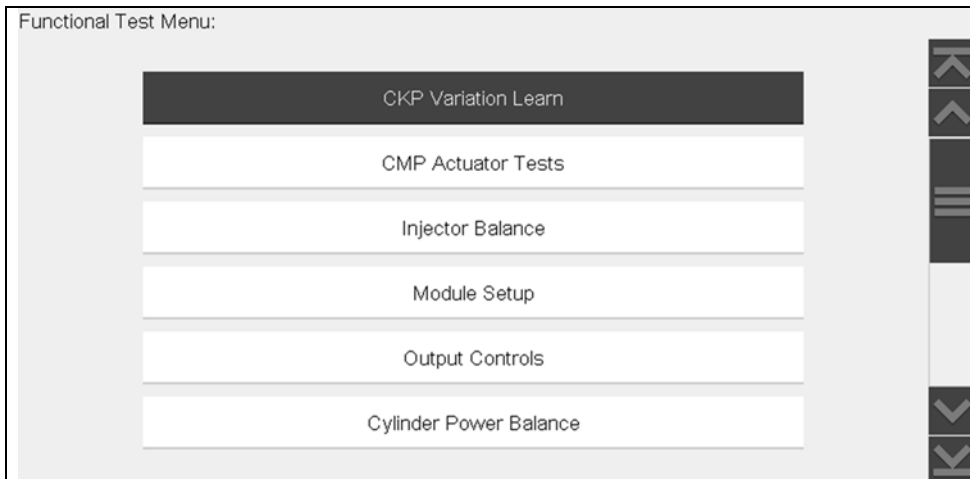

Figure 5-45 Functional test menu

Toggle and variable control tests often display functional test controls on the toolbar at the top of the screen with PID data in the main body.

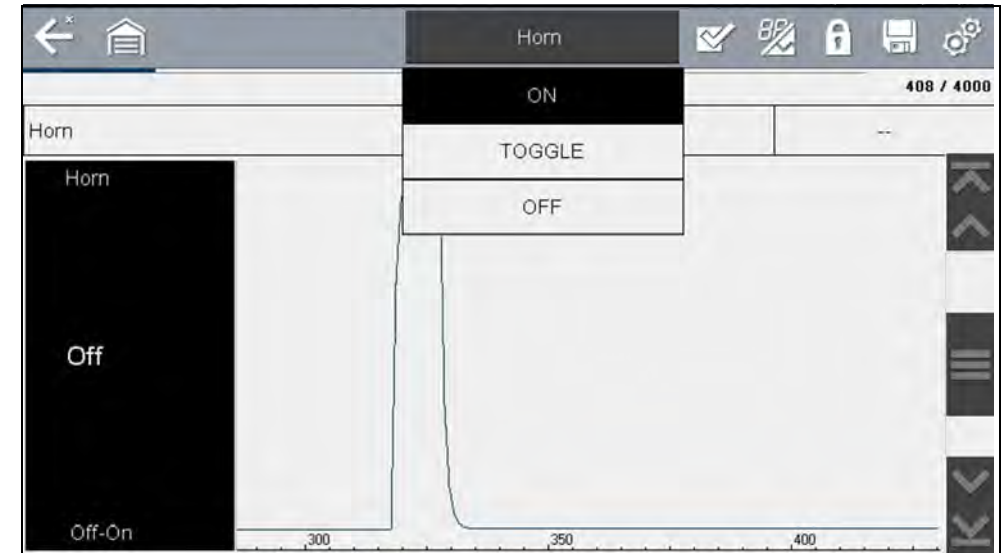

Figure 5-46 Functional test example

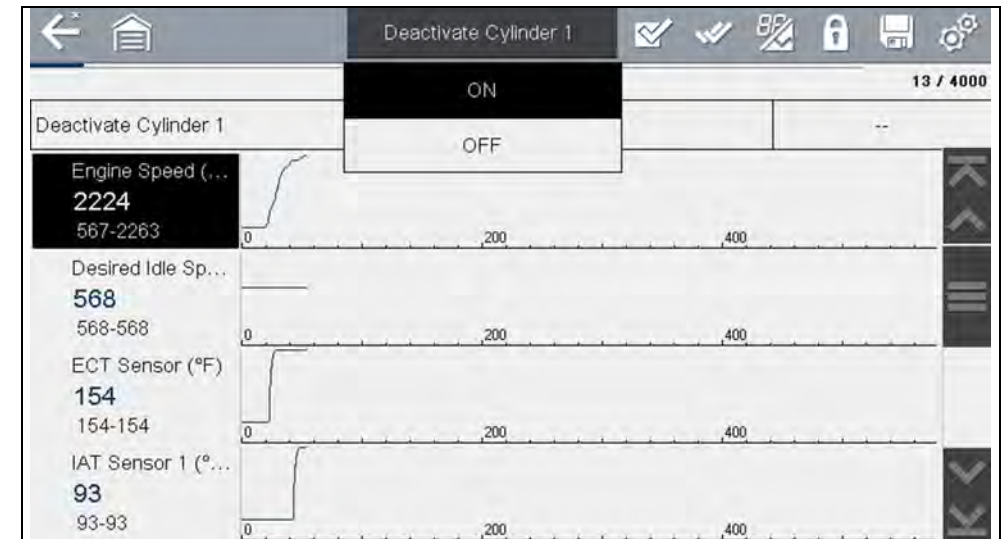

Figure 5-47 Functional test example

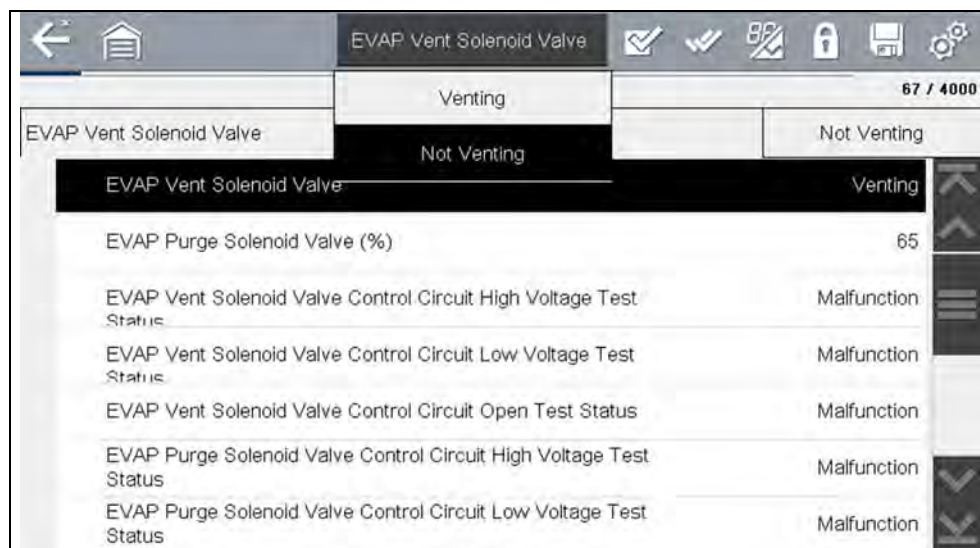

Figure 5-48 Functional test example

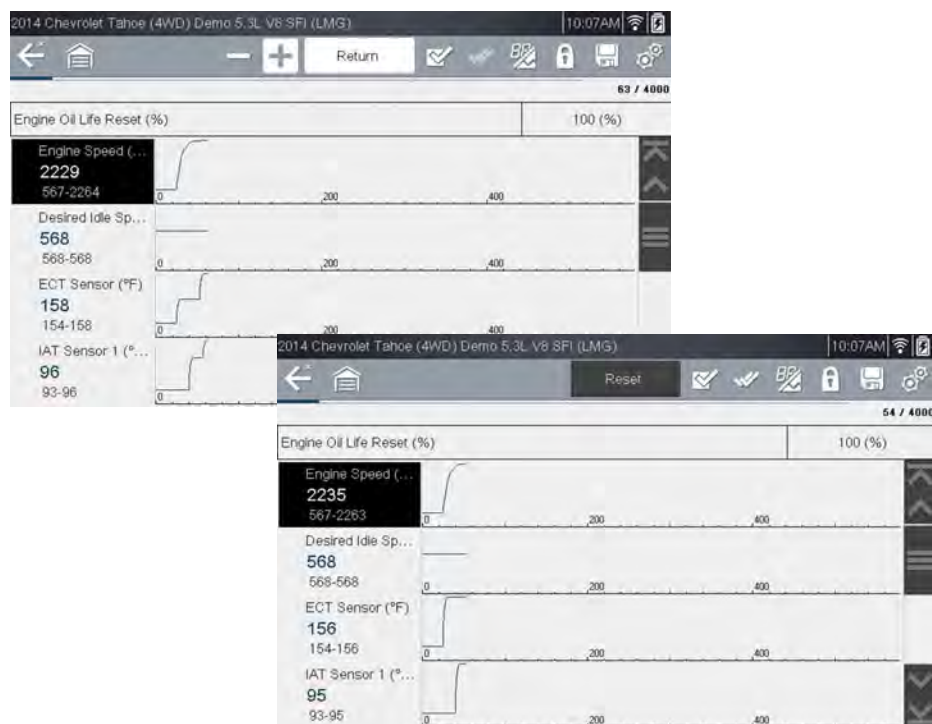

Figure 5-49 Functional test example

A Test icon on the toolbar activates the test, and a Return, or similarly named, icon cancels the test. For variable control tests, the variable value displays between the main body and the toolbar. Plus and Minus icons on the toolbar increase and decrease the variable value.

A Data List icon, shown to the left, is available on the toolbar for some tests. This feature allows you to change which data list displays in the main body without exiting the functional test. The icon is only available when the test is inactive.



5.6 Troubleshooter

NOTE

Troubleshooter appears in a Scanner Main Menu only if tips are available for the system selected on the identified vehicle.

Troubleshooter is a database of experience-based repair strategies and information, that has been compiled and validated by experienced technicians. Troubleshooter simplifies the diagnosis process, as it contains information on virtually all common diagnostic trouble code (DTC) problems and driveability symptoms.

Troubleshooter information is organized into a series of diagnostic tips that are designed to quickly lead you to the root cause of a particular problem. The tips are vehicle-specific, which means only tips that relate to the identified vehicle are presented. Selecting opens a menu that may include:

- **Code Tips**—provides detailed information on setting conditions, testing, and interpreting test results for specific codes ([Figure 5-50](#) and [Figure 5-51](#)).
- **Symptom Tips**—provides diagnostic tests and procedures based on vehicle operation.
- **Time Savers**—provides supplemental information, such as firing order and #1 cylinder location, that may be needed to make a diagnosis.
- **Common Problems**—provides advice and remedies for certain “pattern failures” that have been experienced on vehicles of the same model.
- **Tests and Procedures**—explains how to perform certain tests on the specific test vehicle. Some tips provide specifications and installation information as well.

- **Fast-Track Data Scan**—contains information and guidelines on how to validate data readings for certain sensors and actuators, PID data values are provided.
- **Fast-Track Fixes**—provides actual repair information for related repairs.

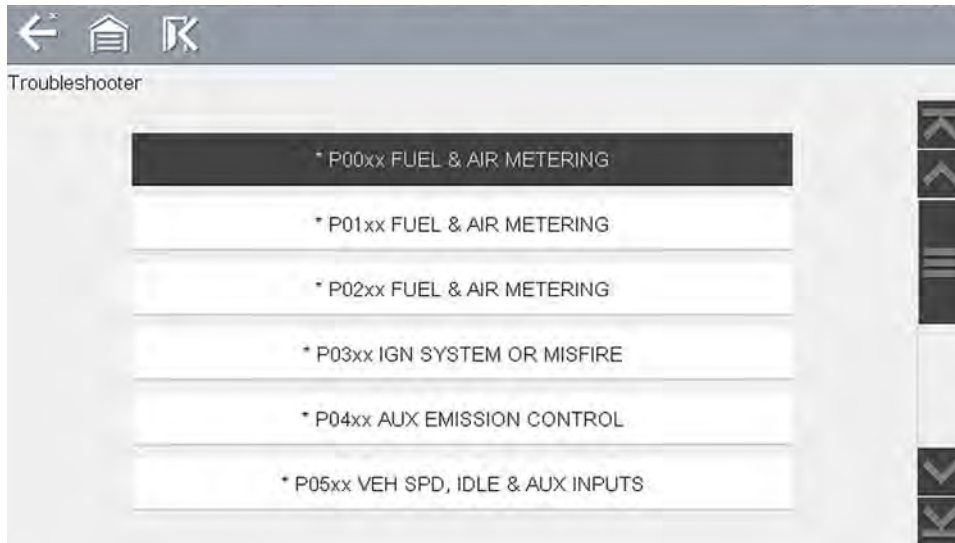

Figure 5-50 Troubleshooter code tip menu

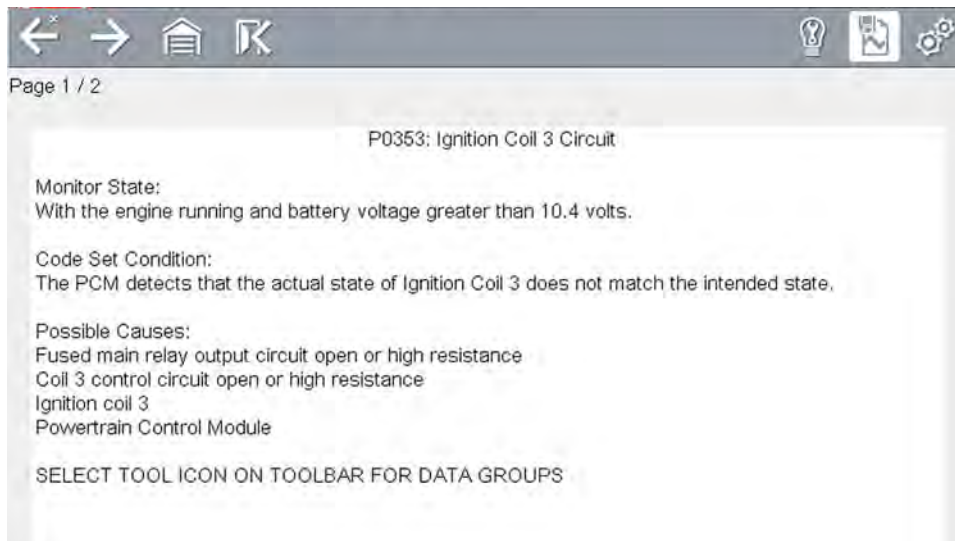

Figure 5-51 Troubleshooter tip (Example: P0353)

Section 6

Vehicle Code Scan



Code Scan allows you to quickly scan all supported vehicle control modules for codes. In addition, Global OBD-II codes and Readiness Monitors are scanned giving you a complete health check of vehicle systems.

One of the benefits of performing a code scan is that you can quickly show your customer diagnostic related issues with a pre scan report, and then after repairing the issues you can use the post scan report to show that the repairs were completed (*Figure 6-1*). In addition, by using The Snap-on Cloud the reports can be given to the customer and also saved for your own records, for more information, see *Vehicle System Report / Snap-on Cloud* on page 44.

IMPORTANT

PRE / POST Scan Importance - As many systems do not turn on the check engine light or other indicator, performing a vehicle code scan before making any repairs may help in troubleshooting, by identifying possible unknown issues that may be related to the present symptoms.

Performing pre and post scans also allows you to record in report format the pre-condition of the vehicle and compare the post scan after work is complete to confirm the repairs were completed properly.

Pre and post scan is required by some manufacturers for pre and post collision work as well as by some insurance companies.

The figure displays two side-by-side screenshots of a 'Vehicle System Report' for a 2016 Nissan Rogue 2.5L L4 MFI (QR25DE). The left report is labeled 'Pre Scan' and shows several diagnostic trouble codes (DTCs) in red boxes: C1704 (Low Pressure Left Front), C1706 (Low Pressure Right Rear), and C1707 (Low Pressure Left Rear) under 'Body Control Module - Codes'; and C1704 (Low Pressure Left Front), C1706 (Low Pressure Right Rear), and C1707 (Low Pressure Left Rear) under 'Tire Pressure Monitor - Codes'. The right report is labeled 'Post Scan' and shows all systems as 'Tests Complete' with green checkmarks. A red arrow points from the 'Pre Scan' report to the 'Post Scan' report, indicating the change in status after repairs.

System	Pre Scan Status	Post Scan Status
Engine	0	0
Transmission	0	0
Antilock Brakes	0	0
Airbag	0	0
Body Control Module - Codes	3 (C1704, C1706, C1707)	0
Electronic Power Steering	0	0
Intelligent Power Distribution Module	0	0
Meter	0	0
Tire Pressure Monitor - Codes	3 (C1704, C1706, C1707)	0
OBDII	0	0
Misfire	Tests Complete	Tests Complete
Fuel System	Tests Complete	Tests Complete
Comprehensive Component	Tests Complete	Tests Complete
EGR/VVT	Tests Complete	Tests Complete
Catalyst	Tests Complete	Tests Complete
Evaporative System	Tests Complete	Tests Complete
Oxygen Sensor	Tests Complete	Tests Complete
Oxygen Sensor Heater	Tests Complete	Tests Complete

Figure 6-1

Main Topic Links

- [Using Code Scan](#) page 41
- [Vehicle System Report / Snap-on Cloud](#) page 44
- [Printing the Vehicle System Report](#) page 44

6.1 Using Code Scan

NOTE

The Code Scan function and results are dependent upon the vehicle. Not all vehicles may support this function.

After you have connected and identified a vehicle through Scanner, Code Scan is available from the Vehicle System menu.

Selecting **Code Scan** from the Vehicle System menu ([Figure 6-2](#)) starts an active scan of vehicle control modules, and opens the Code Scan results screen ([Figure 6-3](#)).

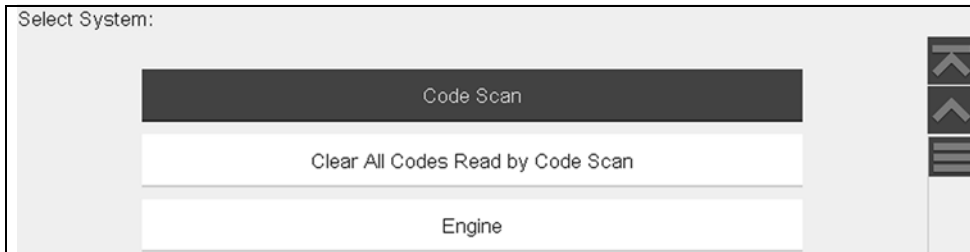

Figure 6-2

NOTE

Selecting **Clear All Codes Read by Code Scan** ([Figure 6-2](#)) erases all DTCs from all vehicle system modules that were read by Code Scan. Selecting this function may not clear global OBD-II codes on some vehicles.

When initially opened ([Figure 6-3](#)), a progress bar is shown at the top indicating the active scanning progress. Once completed, code results are displayed by system.

The following results are displayed as the modules are scanned and are described in the following sections.

- [Total Number of Systems \(modules\) Analyzed](#)
- [List of All the Systems Analyzed with DTCs Totals](#)
- [Global OBDII DTCs](#)
- [Readiness Monitor Test Status](#)

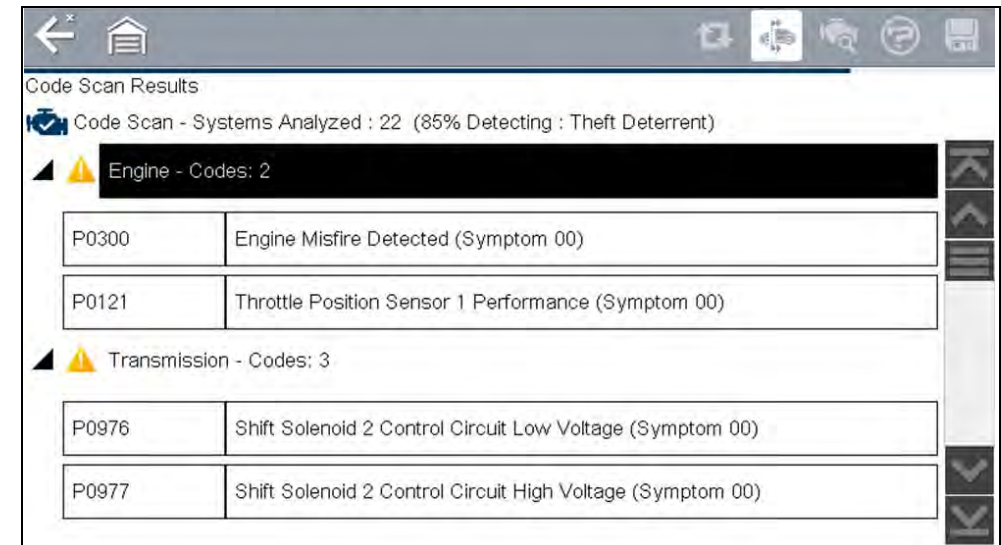

Figure 6-3 Code Scan in process



Code Scan control icons are located on the upper toolbar (Figure 6-3), and provide the following functions.

Icon	Function
	Refresh - Refreshes the code scan data (restarts the code scan)
	System - Opens the main menu of the system selected (highlighted)
	Diagnose - Opens Intelligent Diagnostics for the code selected (highlighted)
	Save - Saves the code scan results as an (.XML) file. See Viewing Codes and Code Scan Results on page 113.
	Help - The Help icon on the Code Scan toolbar opens the Getting Started with Intelligent Diagnostics slideshow. See Getting Started (Demonstration) on page 46.

After the code scan has completed it is automatically saved as an .XML file on the diagnostic tool, and is uploaded to your account on the Snap-on Cloud (if registered and connected).

A confirmation message is displayed indicating that the file was saved (e.g. **Message Example:** "Saving A2810005.XML").

To view the report on the diagnostic tool, see [Viewing the Code Scan Report on the Diagnostic Tool](#) on page 113.

To view/print the report on The Snap-on Cloud, see [Vehicle System Report / Snap-on Cloud](#) on page 44.

NOTE

The code scan can also be saved manually by selecting the **Save** icon.

6.1.1 Total Number of Systems (modules) Analyzed

The total number of systems analyzed is actively displayed at the top of the screen as they are scanned.

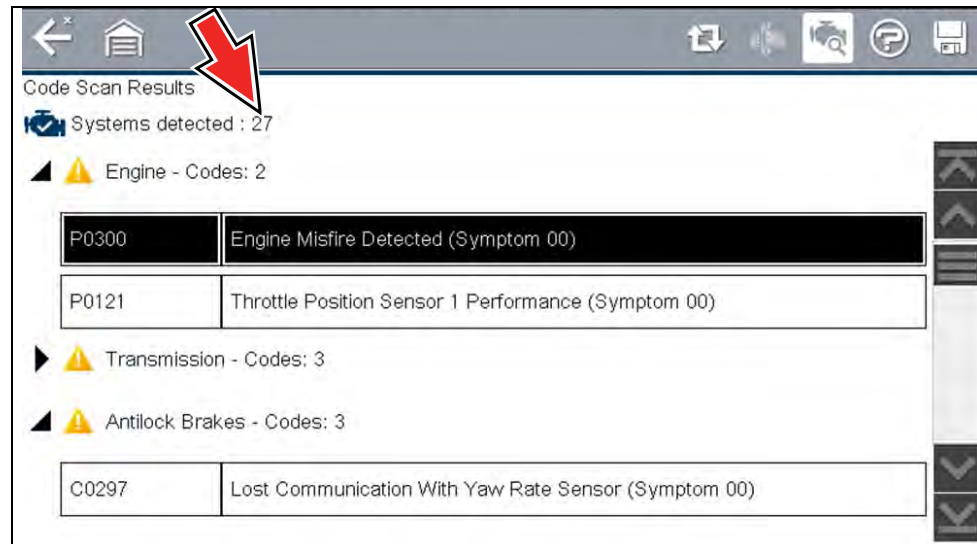

Figure 6-4 Code Scan systems analyzed result total



6.1.2 List of All the Systems Analyzed with DTCs Totals

A categorized system list with DTC totals is displayed in the order they are scanned. To view the main menu for a system in the list, select the system, then select the **System** icon (Figure 6-5).

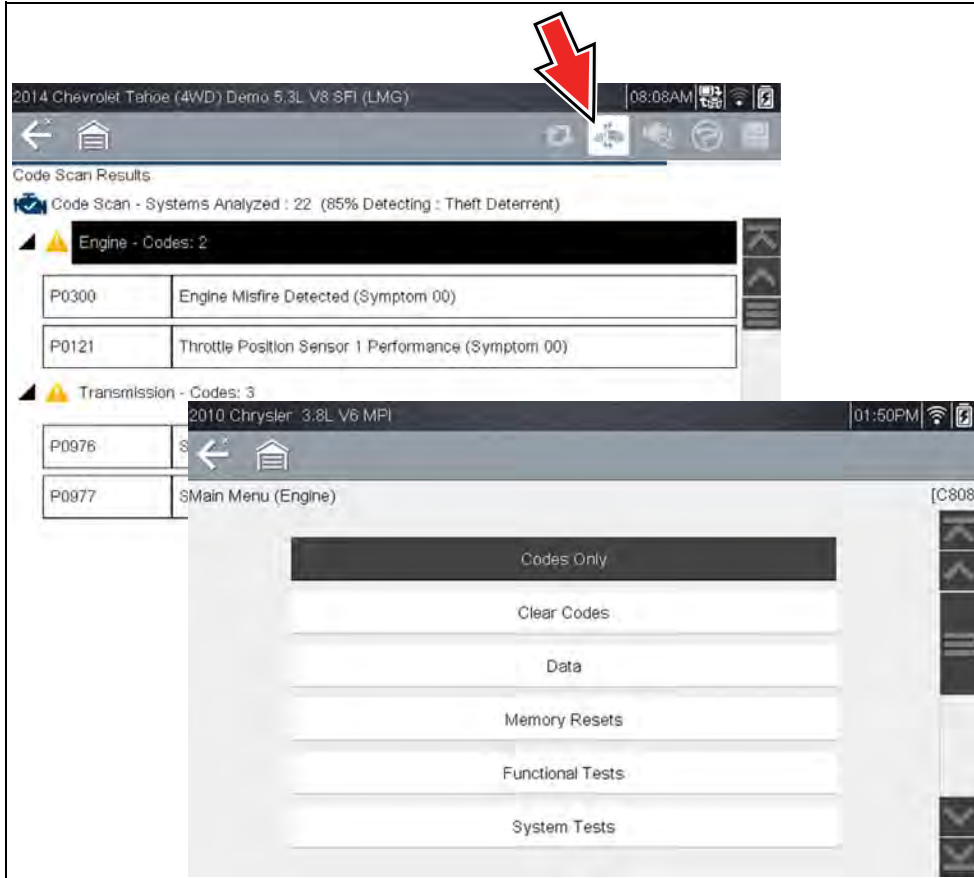

Figure 6-5 System icon (opens Main Menu)

Select the **expand/collapse** icon (Figure 6-6) on the left side of a system category title to expand or collapse a systems' DTC list.

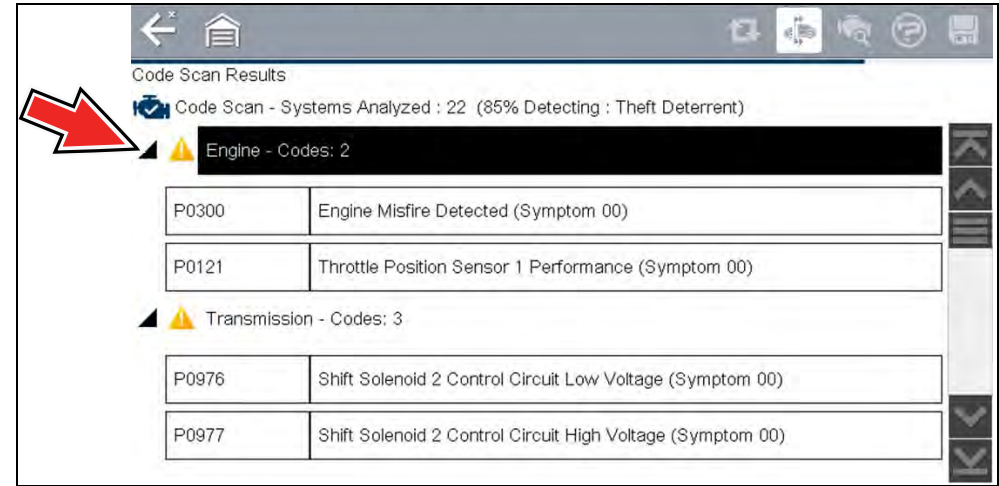

Figure 6-6 Expand/Collapse Icon (expanded result)

6.1.3 Global OBDII DTCs

Towards the end of the Code Scan list Global OBDII DTCs are displayed.

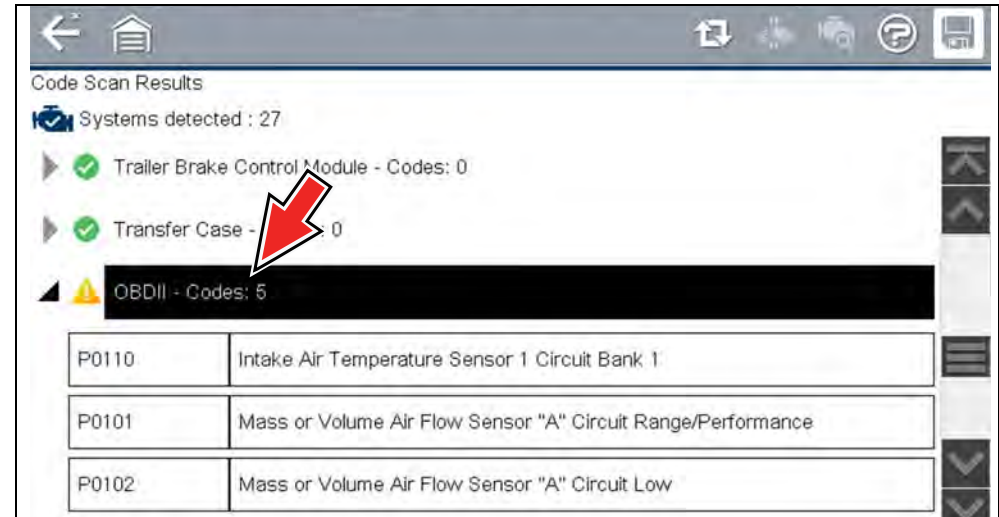

Figure 6-7

**NOTE**

Some 2005 to 2008 vehicles may not display global OBD-II information in the Code Scan list. A message will be displayed to inform you the OBD-II - codes and monitors for this vehicle may be accessed using the global OBD-II function. See [OBD-II/EOBD](#) on page 59.

6.1.4 Readiness Monitor Test Status

At the end of the Code Scan list, readiness monitor test results are displayed as “Tests Complete” or “Not Complete”.

Quick reference indicators are used to show monitor status.

Green icon “✓” mark - Monitor test is complete

- **Grey icon “—” mark** - Monitor test is not complete

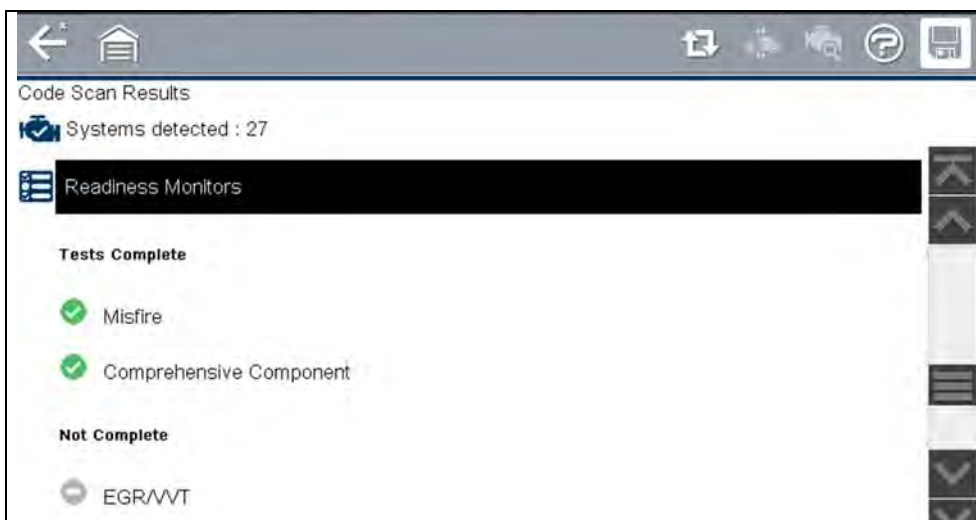

Figure 6-8

NOTE

Monitors that are not supported by the vehicle are not displayed in Code Scan.

6.2 Vehicle System Report / Snap-on Cloud

After a code scan is completed the results of the scan are automatically configured into a Vehicle System Report that is uploaded and saved to your Snap-on Cloud account (if registered and connected). Report examples are shown in [Figure 6-1](#).

Using The Snap-on Cloud, the report can be printed, downloaded, attached to an e-mail or other social media app to share with others. For additional information on using The Snap-on Cloud, see [The Snap-on® Cloud](#) on page 130.

NOTE

Code scan reports are automatically saved each time a code scan is performed. The report is automatically uploaded to your Snap-on Cloud account.

The code scan/vehicle system report includes:

- Basic vehicle information
- A list of the code scan results by system
- Individual system DTCs with a brief description
- Global OBD codes
- Readiness monitor test status

6.2.1 Printing the Vehicle System Report

Use The Snap-on Cloud to print the vehicle system report from your PC or mobile device, see [The Snap-on® Cloud](#) on page 130.

The vehicle system report can also be customized and printed using ShopStream Connect - See [Printing the \(Code Scan\) Vehicle System Report](#) on page 147.



Introduction

Intelligent Diagnostics provides access to the latest **code-specific** data, information, and tests, all obtained from actual shop repair orders and industry professionals.

Intelligent Diagnostics may include the following **code-specific** information and data (if available):

- **Technical Bulletins** - View Safety Recalls, Technical Service Bulletins (TSB's), and OEM Campaigns
- **Top Repairs Graph** - View a graph of the specific parts and procedures most frequently used to fix the selected code or symptom.
- **Smart Data** - View custom code-specific PID lists developed to show you just the data you need related to the code. Smart Data also highlights PIDs that are operating outside known-good values.
- **Functional Tests and Reset Procedures** - Test components using command functionality directly from the diagnostic tool and reset service indicators.
- **Guided Component Tests** - Test components quickly and accurately with Guided Component Tests that include step-by-step instruction, component specifications and troubleshooting information.
- **Real Fixes and Troubleshooter** - View code-specific procedures, tests, and tips that have been gathered from actual shop repair orders and industry professionals.

7.1 Main Topic Links

- [Getting Started \(Demonstration\)](#) page 46
- [Accessing Intelligent Diagnostics](#) page 47
- [Main Menu Navigation](#) page 48
- [Code Results Dropdown Menu](#) page 49
- [Top Repairs Graph](#) page 49
- [Technical Bulletins \(OEM Information\)](#) page 49
- [Smart Data](#) page 50
- [About Smart Data PIDs](#) page 51
- [Functional Tests and Reset Procedures](#) page 51
- [Guided Component Tests \(GCTs\)](#) page 52
- [Real Fixes](#) page 53
- [Troubleshooter](#) page 54



7.2 Getting Started (Demonstration)



The Help icon is available from Scanner and OBD-II code related screens (e.g. display codes, code scan). The icon is also available from the Intelligent Diagnostics main menu.

Selecting **Help** ([Figure 7-1](#)), starts a built-in slideshow describing the basic features of Intelligent Diagnostics.

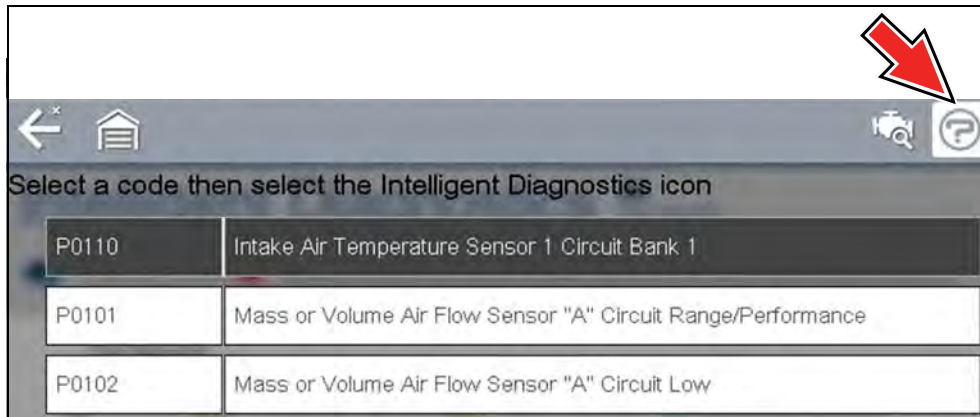

Figure 7-1

Slideshow example screens are shown in [Figure 7-2](#).



Figure 7-2

7.3 Accessing Intelligent Diagnostics

To access Intelligent Diagnostics on the diagnostic tool:

- you must have authorized access to Intelligent Diagnostics, contact your sales representative for information.
- turn the Wi-Fi radio on and connect to a wireless network. For Wi-Fi setup and connection see, [Configure Wi-Fi on page 122](#).

NOTES

The diagnostic tool is equipped with the ability to connect to a Wi-Fi network, however the connection is solely dedicated to our Snap-on Services Network.

Before you begin using Intelligent Diagnostics you must connect to a wireless network and turn the Wi-Fi radio on.

7.3.1 Informative Messages

Messages may be displayed to inform you of pending issues or general status. Depending on your access and connection status, the following are typical messages that may be displayed:

- **Content May Be Available!** - indicates content may be available, however you are not currently connected to the Web Services Network. This message may be caused by a Wi-Fi connection issue, or you do not have access to the application. See [Wi-Fi Connection / Troubleshooting on page 124](#) for Troubleshooting information.
- **No connection. Please try again later.** - indicates you are not currently connected to the Web Services Network, except when displayed in the OBD/EOBD function as Repair Information Services are not accessible in OBD/EOBD mode. If this message is displayed in the Scanner function, it may be caused by a Wi-Fi connection issue, or you do not have access to the feature. See [Wi-Fi Connection / Troubleshooting on page 124](#) for Troubleshooting information.
- **Loading content** - indicates information is being accessed from the Web Services Network.
- **A new diagnostic software upgrade is available. Contact your sales representative for details.**
- **Your access has expired. See your Sales representative to renew.** - indicates your access to the Web Services Network has expired and you should contact your sales representative.

7.3.2 Using Intelligent Diagnostics (Code Results)



To open Intelligent Diagnostics, select the **Diagnose** icon when viewing Scanner code results. For code results information, see [Codes Menu on page 18](#).

To review basic Scanner operation procedures, see [Using Intelligent Diagnostics \(Code Results\) on page 47](#).

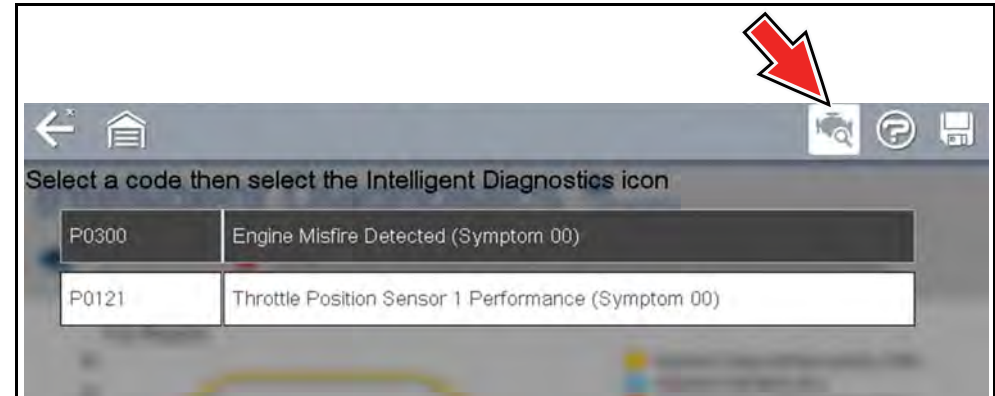

Figure 7-3 Code Results - Diagnose Icon

7.4 Main Menu Navigation

Intelligent Diagnostics information modules are contained in one multi-card main menu. This allows you to easily select a card (e.g. Technical Bulletins, Smart Data, Real Fixes, etc), view the data and then quickly return to the main menu to open another card.

NOTE

Some Intelligent Diagnostics functions are similar to Scanner functions and may share navigation and controls instructions. These topics use cross references to the applicable common information.

Basic navigation is accomplished by selecting the desired menu card to open that function.

Use the **Back** icon on the upper toolbar to navigate back to the previous screen.

The following descriptions are used with [Figure 7-4](#).

- Wi-Fi Connection Status Indicator** - A Wi-Fi connection indicator (cloud icon) is provided on the top of the screen ([Figure 7-4](#)). This icon is also used to indicate service expiration, the icon changes color to red, and displays the word "Expired" in the event your access has expired.
- Expand /Collapse icon** - Expands / Collapses Top Repairs graph onscreen
- Help icon** - Opens a built-in slideshow ([Getting Started \(Demonstration\)](#)) describing the basic features of Intelligent Diagnostics.
- Code Results Dropdown Menu** - Displays selectable list of all present codes.
- Top Repairs Graph** - Graphical display of the specific parts and procedures most frequently used to fix the selected code or symptom
- Technical Bulletins (OEM Information)** (card) - Lists code-specific Safety Recalls, Technical Service Bulletins (TSB's), and OEM Campaigns
- Smart Data** (card) - Displays a custom list of code-specific PIDs, and highlights PIDs operating outside known-good limits.
- Functional Tests and Reset Procedures** (card) - Perform code-specific functional component tests directly from the diagnostic tool.
- Guided Component Tests (GCTs)** (card) - Test code-specific components quickly and accurately with Guided Component Tests that include step-by-step instructions, component specifications, and troubleshooting information.
- Real Fixes** (card) - Provides a list of code-specific procedures and tests (Real and Related Real Fixes) that have been gathered from actual shop repair orders and presented in a complaint, cause, and correction format. The Real Fix displayed on the Main Menu is the most common fix to date.
- Troubleshooter** (card) - Opens a list of code-specific tips gathered from industry experts.

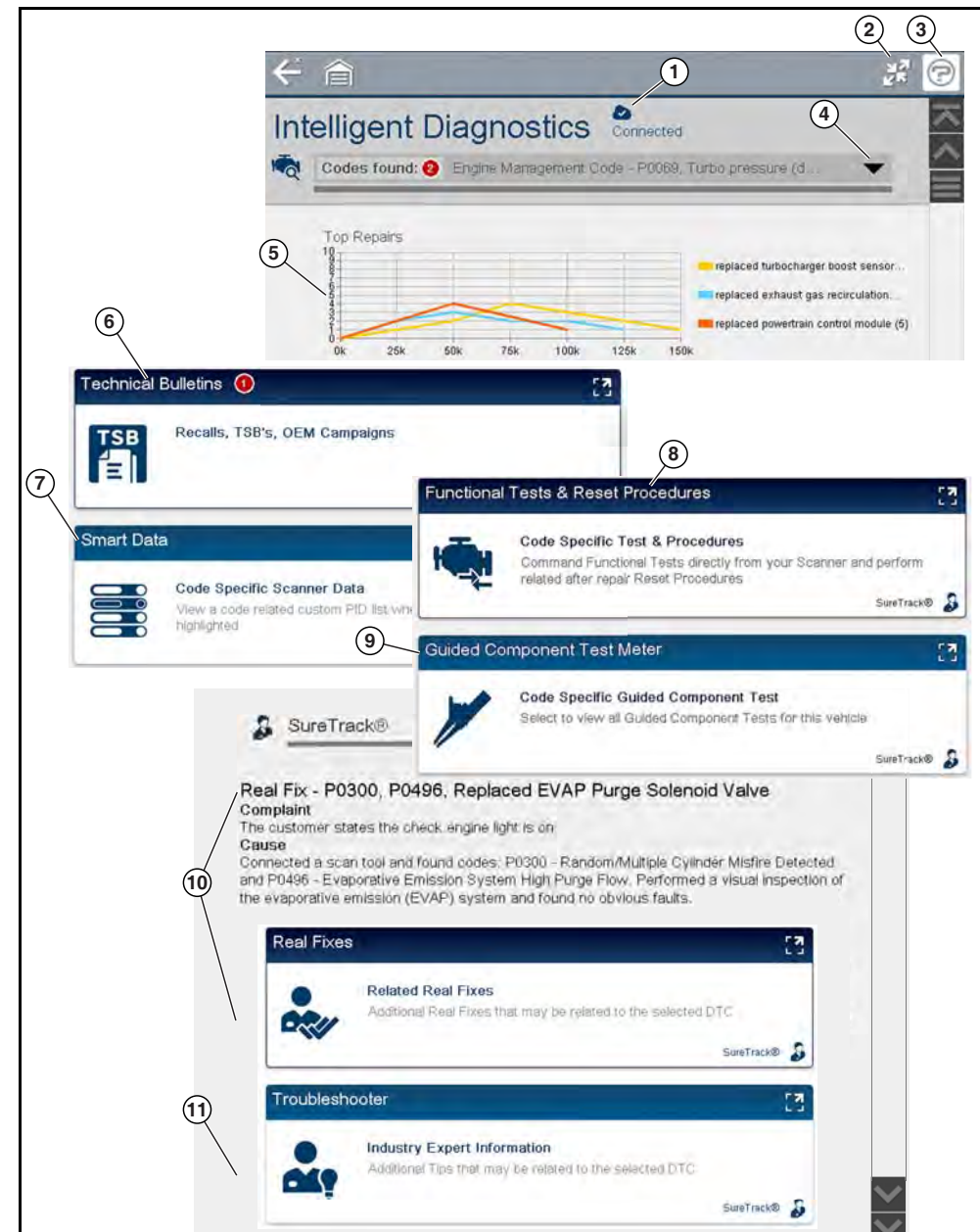

Figure 7-4 Multi-card menu



7.5 Code Results Dropdown Menu

The Code Results Dropdown menu allows you to quickly choose any of the scanned codes from the code list, without having to exit Intelligent Diagnostics. Select a code to view specific data about that code within Intelligent Diagnostics.

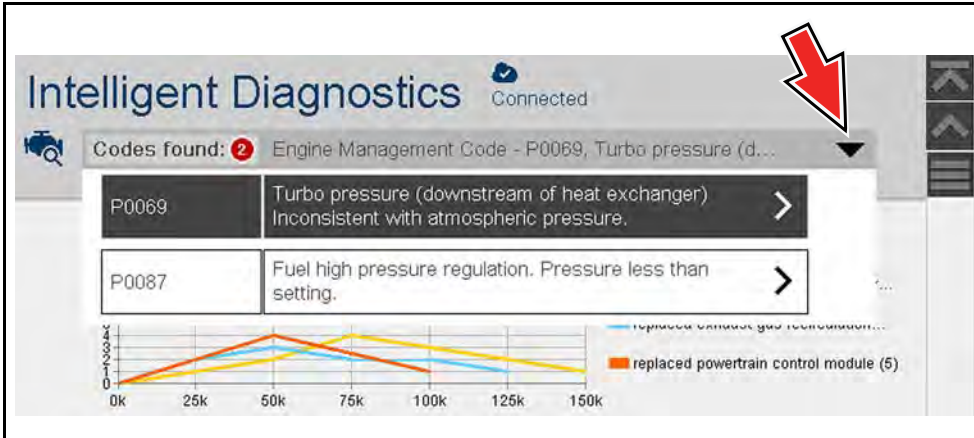

Figure 7-5 Dropdown Menu

7.6 Top Repairs Graph

The Top Repairs Graph (Figure 7-6) shows the most common verified fixes and procedures.

Example - In the graph shown below, the most common fix for the code was replacing the turbo boost sensor. This fix occurred 12 times, with the most occurrences (4) at 75k miles in vehicles with up to 150k miles.

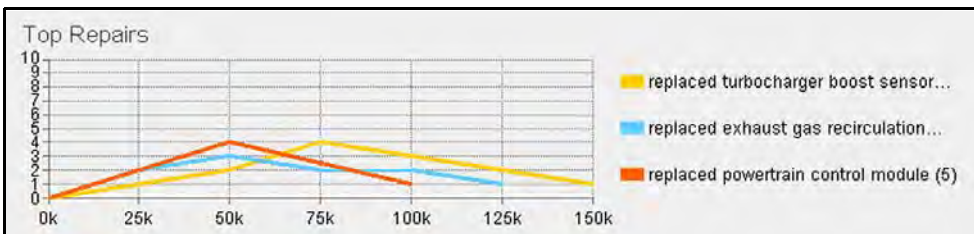

Figure 7-6 Top Repairs Graph (multiple components)

7.7 Technical Bulletins (OEM Information)

The Technical Bulletins card (Figure 7-7) provides a quick link to OEM Recall, TSB and Campaign information that may be available for the selected code.

- A red icon (Figure 7-7) indicates the total number of Recalls, TSBs, and OEM Campaigns that have been found.
- A green icon indicates a search was performed and no results were found.

Selecting the Technical Bulletins card (Figure 7-7) provides a detailed list view of the available OEM Recalls, TSBs, and Campaigns (Figure 7-8).

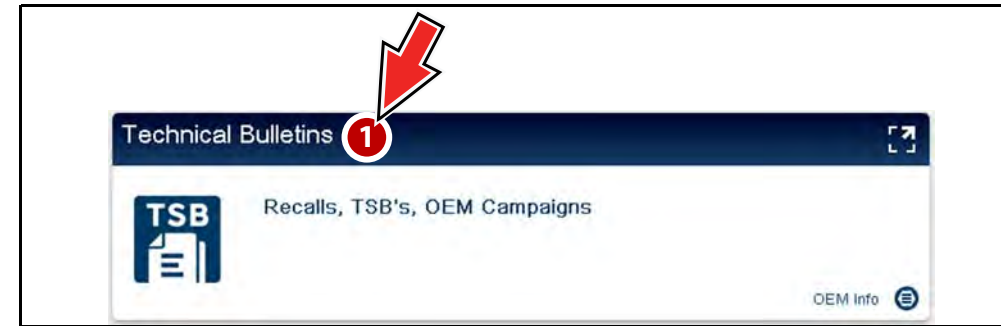

Figure 7-7 Technical Bulletins card

Select a topic from the list (Figure 7-8) to view detailed information on the topic (Figure 7-9).



Figure 7-8 Bulletin, Recall, Campaign list



SES TRACTION CONTROL LAMP ON AND ENGINE RUNS ROUGH WITH DTC P0300

TECHNICAL SERVICE BULLETIN
 Reference Number(s): PIP5298, Date of Issue: May 22, 2015
 Affected Model(s): 2014-2015 Chevrolet Silverado, Suburban, Tahoe 2014-2015 GMC Sierra, Yukon, Yukon XL 2015 Cadillac Escalade Engine 4.3L LV3 5.3 L83 6.2 L86

SERVICE INFORMATION
 The following diagnosis might be helpful if the vehicle exhibits the symptom(s) described in this PI.

CONDITION/CONCERN
 Some customers may comment on an SES light with DTC P0300 set and/or a rough running engine concern

RECOMMENDATION/INSTRUCTIONS
 If SI diagnostics have been completed with no trouble found inspect for a possible terminal tension concern on both the ignition coil power feed for a possible cause of the DTC P0300 set

Figure 7-9 TSB example

TAC Data - REDUCED POWER 49 / 4000

REDUCED POWER	NO
APP SENSORS(%)	0
APP IND ANGLE(%)	25
TP DES ANGLE(%)	0
TP IND ANGLE(%)	22
APP 1&2 AGREE	YES
TPS 1&2 AGREE	YES
APP1(V)	0.00

Figure 7-11

7.8 Smart Data

Smart Data filters out all non-relevant PIDs and shows you a custom list of PIDs related to the selected code. In addition, specific PIDs in the list are prearmed to flag values that are out of the expected range.

IMPORTANT

Smart Data works best when the vehicle is idling at operating temperature with no load present. Always refer to OEM service information for specific PID range limit information.

Selecting the Smart Data card (Figure 7-10) opens the custom code-specific PID list (Figure 7-11 PID List View), (Figure 7-12 PID Graph View).

Smart Data

Code Specific Scanner Data
 View a code related custom PID list where anomaly PID values are highlighted

SureTrack®

Figure 7-10

TAC Data - ENGINE SPEED (RPM) 640 / 4000

APP IND ANG...	20	0-26
TP DES ANGL...	0	0-17
TP IND ANGLE...	21	4-22
ENGINE SPEE...	1997	567-2297

Figure 7-12



Selecting the **Back** icon opens the Smart Data main menu ([Figure 7-13](#)), which includes additional data list options (bottom of screen).

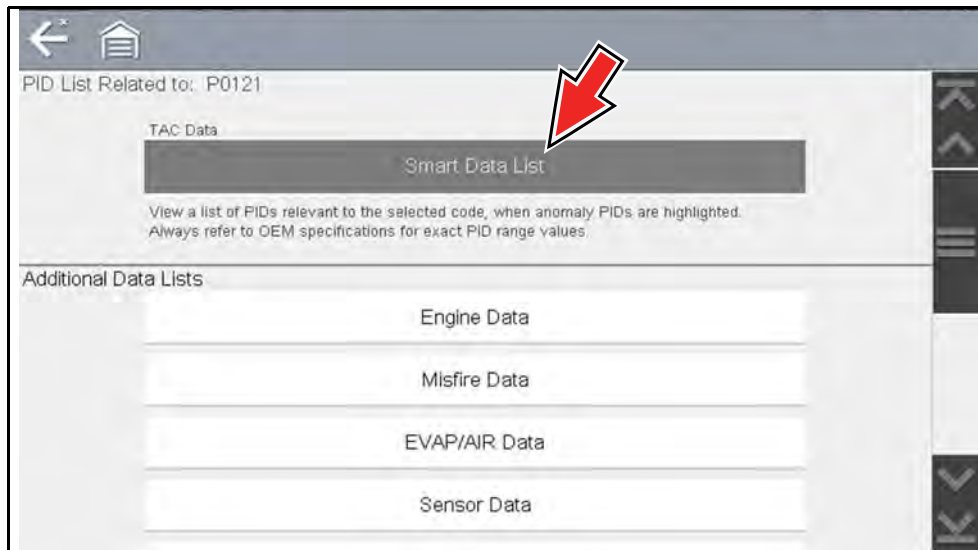



Figure 7-13

7.8.1 About Smart Data PIDs

Features and operation of Smart Data PIDs:

- Any PID with a flag displayed has been preset and prearmed.
 - A red flag  indicates the PID is operating out of range and the trigger has been activated.
 - A blue outlined flag indicates the PID is armed, and operating within its limits (trigger not activated).
- PID trigger points (upper/lower value limits) are automatically set using known-good upper/lower limit values.
 - Note** - Upper/lower limit lines are not displayed on the graph, and values are not displayed in settings.
- Smart Data PID triggers can be (overridden) set manually, see [Using Triggers on page 33](#) for instructions.
 - Note** - Manually setting trigger values will override the preconfigured Smart Data values.
 - Note** - Manually set triggers will display upper and lower trigger limit lines in the graph.

When a trigger is activated:

- Data collection is briefly paused as the Scanner captures a recording of all available PID data, and saves it as a data file.
- An audible alarm is sounded
- A message displays indicating a data file was saved.
- Data collection continues.
- The activated PID trigger is disarmed. **Note** - if a different PID trigger is activated subsequently, an additional data file will be recorded.
- A red cursor line is displayed on the graph ([Figure 7-14](#)) of the PID with the activated trigger to indicate where the trigger occurred.
- A green cursor line is displayed on all the other PID graphs to indicate their relationship to where the trigger occurred.
- A gray cursor line is displayed to indicate the point at which the data was paused to save the data file.

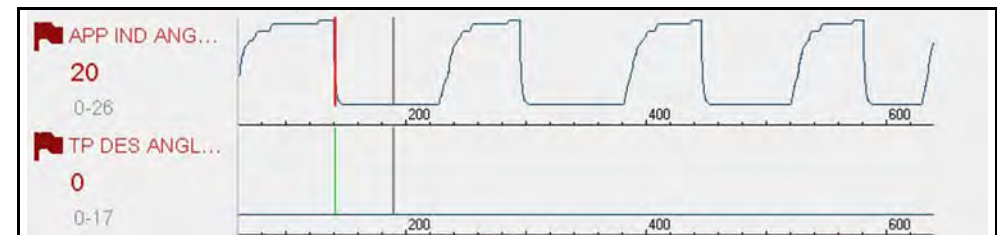

Figure 7-14 Triggers activated

7.9 Functional Tests and Reset Procedures

Selecting the Functional Tests and Reset Procedures card ([Figure 7-15](#)) opens the Tests main menu ([Figure 7-16](#)), which displays a list of bi-directional tests and procedures related to troubleshooting the selected codes. Functional tests and reset procedures allow you to manually control certain component operations (e.g. turn fuel pump on/off) and reset certain control module values (e.g. reset fuel trim) directly from the diagnostic tool to confirm the operation of components and validate repairs.

Intelligent Diagnostics Functional Tests and Reset Procedures operation and navigation is similar to the Functional Tests within the Scanner function. For additional information see [Functional Tests](#) on page 37.



Figure 7-15

Additional Functional Tests and Reset options may be displayed at the bottom of the screen, depending on the vehicle. These options are not DTC related, but are vehicle specific related, and may be useful in troubleshooting or validating repairs.

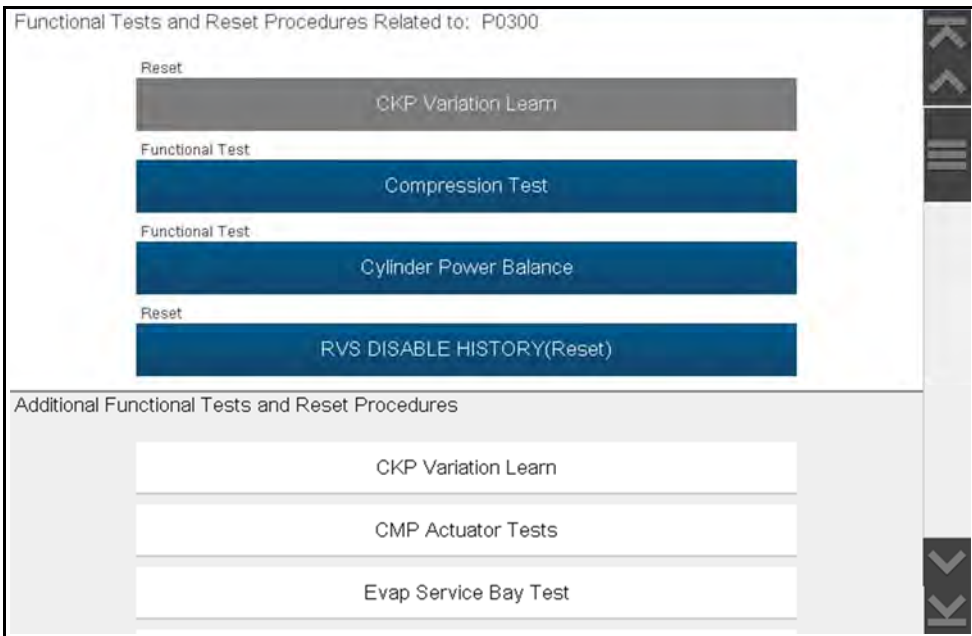

Figure 7-16

7.10 Guided Component Tests (GCTs)

Selecting the Guided Component Tests card ([Figure 7-17](#)) opens the Components Tests main menu ([Figure 7-18](#)), which displays a menu list of tests related to the troubleshooting of the selected codes.

Intelligent Diagnostics Guided Component Tests operation and navigation is similar to the main Guided Component Tests function accessed from the Home screen. For additional information see [Guided Component Tests](#) on page 66.



Figure 7-17

Additional Component Tests may be displayed at the bottom of the screen ([Figure 7-18](#)) depending on the vehicle. These options are not DTC related, but are vehicle specific related, and may be useful in troubleshooting or validating repairs.

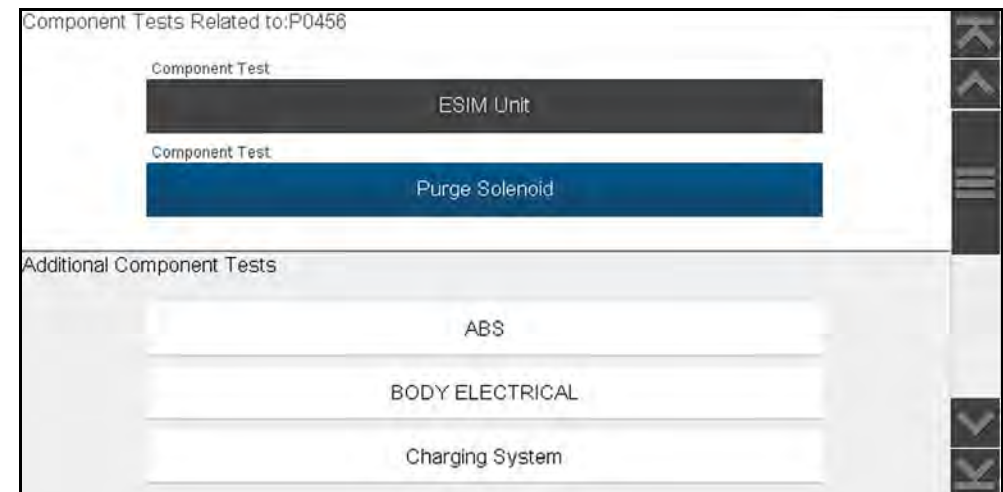

Figure 7-18

After a test is selected a component test sub-menu opens. The component test sub-menu may include various test options and a Component Information selection (*Figure 7-19*) if supported.

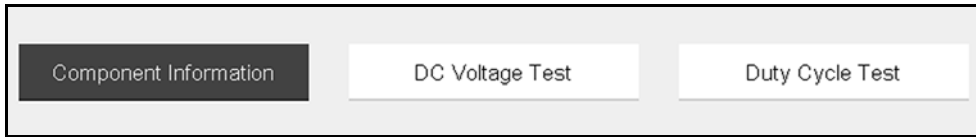

Figure 7-19

Guided Component Tests provide you with step-by-step instructions to guide you through the process of performing component tests. They may include component information and specifications (*Figure 7-20*).

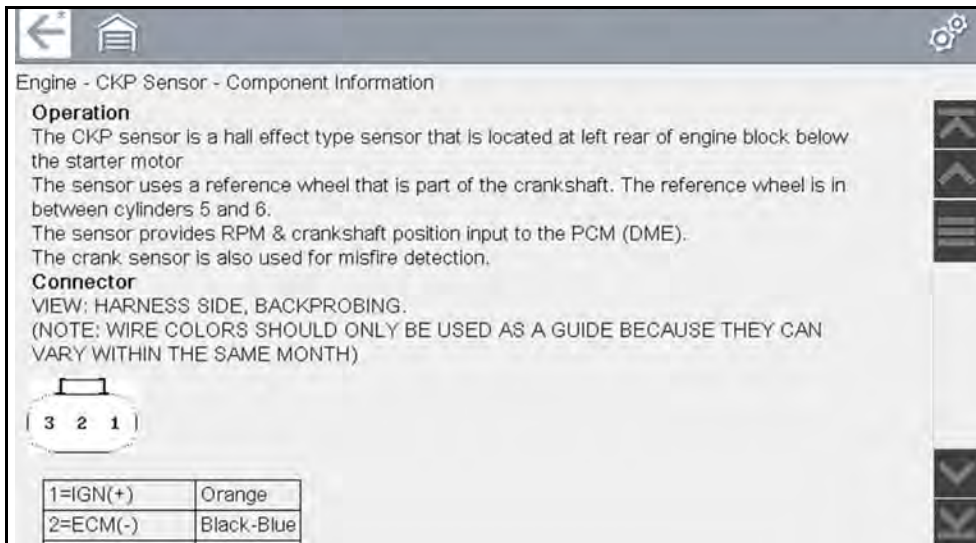

Figure 7-20

Some tests may also automatically configure the multimeter or lab scope to perform the selected test (*Figure 7-21*). For additional information on using these functions, see *Guided Component Tests* on page 66.

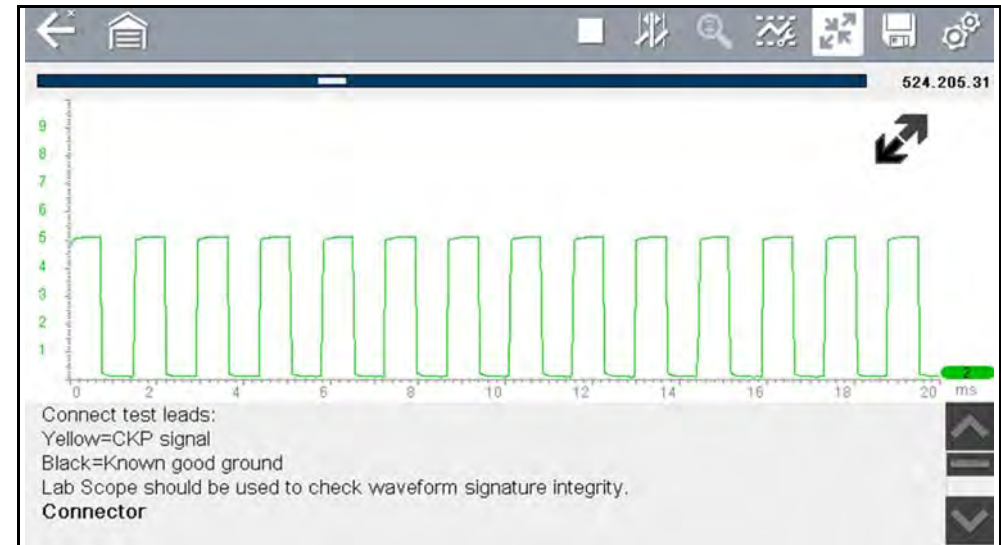

Figure 7-21

7.11 Real Fixes

Select the **Real Fixes** card (*Figure 7-22*) to view a list (*Figure 7-23*) of code-specific procedures, tests and repair tips (Real and Related Real Fixes) that have been gathered from actual shop repair orders.

The Real Fix displayed on the Main Menu (above the Real Fixes card) is the most common Real Fix to date.

NOTE

Fixes have been researched and obtained from professional automotive OEM and specialty technicians from a vast range of repair shops. Fixes may not be available for every vehicle and/or DTC.

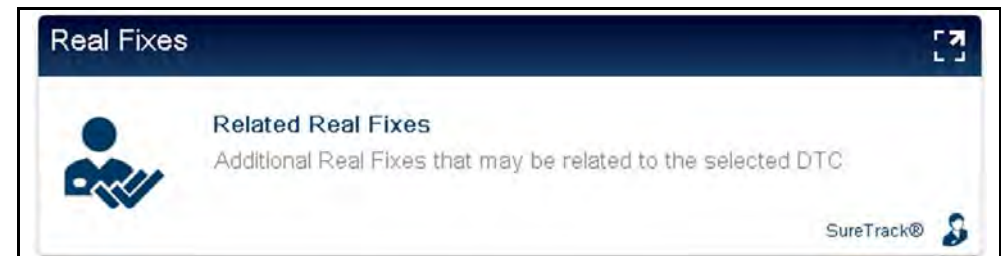

Figure 7-22



Related Real Fixes	Fixed It!
P0300, P0496, Replaced EVAP Purge Solenoid Valve Connected a scan tool and found codes: P0300 - Random/Multiple Cylinder Misfire Detected and P0496 - Evaporative ...	3
P0300, Replaced Ignition Coil, Spark Plugs Connected a scan tool and found code P0300 - Random/Multiple Cylinder Misfire Detected. Inspected the ignition syst...	2
P0300, Replaced Fuel Injector Connected a scan tool and found code P0300 - Random/Multiple Cylinder Misfire Detected. Inspected the air intake sys...	1

Figure 7-23

Select a Related Real Fix from the list (Figure 7-23) to view detailed information about the fix (Figure 7-24) in a Complaint - Cause - Correction format.

3 Fixed It!

Real Fix - P0300, P0496, Replaced EVAP Purge Solenoid Valve

Complaint
The customer states the check engine light is on.

Cause
Connected a scan tool and found codes: P0300 - Random/Multiple Cylinder Misfire Detected and P0496 - Evaporative Emission System High Purge Flow. Performed a visual inspection of the evaporative emission (EVAP) system and found no obvious faults. Used the scan tool to command the EVAP purge solenoid valve open and closed and found the solenoid valve was inoperative. Performed a visual inspection of the EVAP purge solenoid valve wiring harness and found no obvious faults. Used the scan tool to command the EVAP purge solenoid valve open and closed while using a multi-meter to check for the presence of voltage and ground at the EVAP purge solenoid valve, and found both were present. With the EVAP purge solenoid valve disconnected, used a vacuum pump to apply vacuum to the EVAP purge solenoid valve and found the valve did not hold the applied vacuum, which indicated the EVAP purge solenoid valve was stuck open. These test results verified the EVAP purge solenoid valve was faulty.

Correction
Replaced the EVAP purge solenoid valve, cleared codes, performed a road test and verified the vehicle operated properly. The check engine light did not illuminate and no fault codes

Figure 7-24

7.12 Troubleshooter

Select the **Troubleshooter** card (Figure 7-25) to view a list (Figure 7-26) of code-specific tips gathered from industry professionals.

NOTE

Tips have been researched and obtained from professional automotive OEM and specialty technicians from a vast range of repair shops. Tips may not be available for every vehicle and/or DTC.

Troubleshooter

Industry Expert Information

Additional Tips that may be related to the selected DTC

SureTrack®

Figure 7-25

Select a **Related Tip** from the list (Figure 7-26) to view the information (Figure 7-27).

Related Tips

[P0121](#)
P0121 Throttle position sensor

[P0191](#)
...P0222, P0223, P0261, P0262, P0264, P0265, P0267, P0268, P0270, P0271, P0300, P0301 P0306, P0351 P0356, P...

[P0300](#)
P0300 Engine Misfire Detected Circuit/System Description: The engine control module (ECM) uses information...

[P0315](#)
...Is not within the crankshaft position system variation compensating values stored in the ECM then P0300 may set. If ...

[P0667](#)
...P0174, P0175, P0201, P0202, P0203, P0204, P0205, P0206, P0207, P0208, P0300, P0301, P0302, P0303, P0304, ...

Figure 7-26

**Tip - P0121****P0121 Throttle Position Sensor 1 Performance****Circuit/System Description:**

The throttle body assembly contains a contact-less inductive throttle position sensing element that is managed by a customized integrated circuit. The throttle position sensor is mounted within the throttle body assembly and is not serviceable. The engine control module (ECM) supplies the throttle body with a 5V reference circuit, a low reference circuit, an H-bridge motor directional control circuit, and an asynchronous signal/serial data circuit. The asynchronous signal means communication is only going from the throttle body to the ECM. The throttle body cannot receive data from the ECM over the signal/serial data circuit. The throttle position sensor provides a signal voltage that changes relative to throttle blade angle. The customized integrated circuit translates the voltage based position information into serial data using the Society of Automotive Engineers (SAE) J2716 Single Edge Nibble Transmission (SENT) protocol. The throttle position sensor information is transmitted between the throttle body and the ECM on the signal/serial data circuit. The ECM decodes the serial data signal into separate voltages which are displayed on a Scanner as the voltage inputs from TP sensors 1 and 2.

Conditions for Running the DTC:

1. The engine speed is between 500-6,800 RPM.
2. The engine coolant temperature (ECT) is -7 to +126°C (19-259°F).

Figure 7-27



This chapter describes the basic operation, and navigation of the TSBs (Technical Service Bulletins) function.



The **TSBs** icon is located on the Home screen.

The TSBs function can provide the following Original Equipment Manufacturer (OEM) Technical Service Bulletin information (if available) for the identified vehicle:

- Symptoms
- Causes or Defects*
- Solutions*
- Repair Times
- Parts Required

* Illustrations provided if available.

NOTES

— To use the TSB feature you **MUST** have the current software upgrade installed on your diagnostic tool, and be connected to a wireless network with Internet access.

— If you experience a wireless network connection loss, TSB data will not refresh and/or may cause the program to stop. To continue use, you must re-establish your Internet connection.

8.1 Operation

NOTE

The information and procedures provided by the TSBs function is vehicle specific, therefore a vehicle must be identified before information can be displayed.

There are two methods to access this function:

- **Selecting the TSBs icon from the Home screen** - See [Viewing TSBs \(using the Home Screen icon\)](#) on page 56.
- **Selecting the TSBs menu option from within a current Scanner session** - See [Viewing TSBs \(using Scanner\)](#) on page 58.



Viewing TSBs (using the Home Screen icon)

1. Select the **TSBs** icon from the Home Screen ([Figure 8-1](#)).

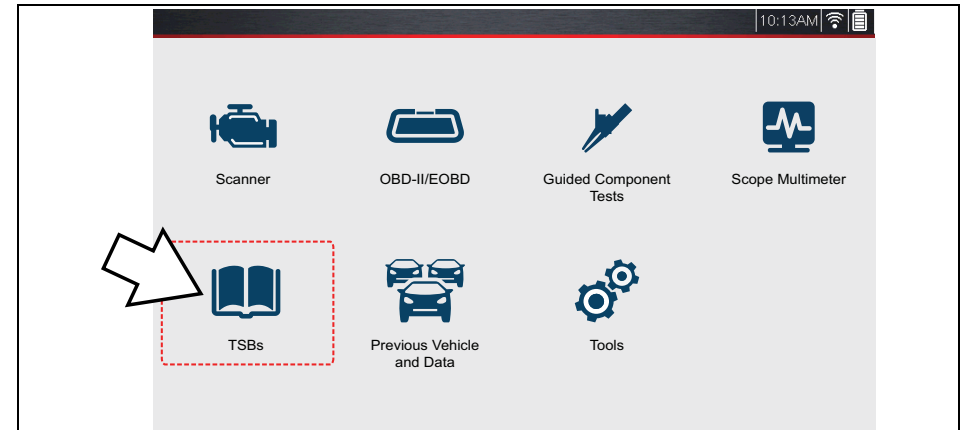

Figure 8-1 Home Screen - TSBs icon

2. Identify the vehicle, by following the screen prompts to select the vehicle information (e.g. **make, year, model**, etc.).
3. Select **OK**.

4. Select a vehicle area, (e.g. **Engine**, **Transmission**, **Brakes**, etc) (Figure 8-2).

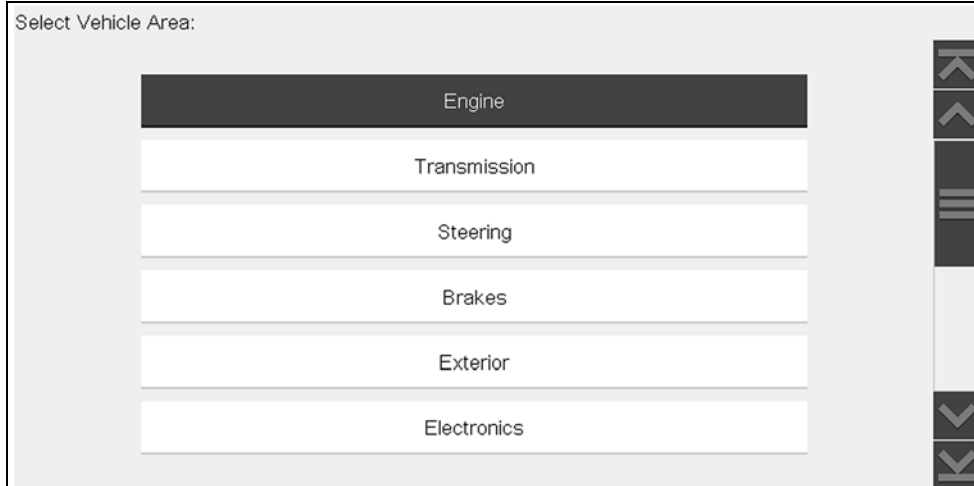

Figure 8-2 Vehicle Area Menu

5. Select the desired TSB.

If applicable, use the scroll bar or directional buttons (▲, ▼) to scroll up/down to view all of the information.

The example shown in Figure 8-3 shows a typical TSB, describing the symptom, cause, solution, repair time, parts required, and shows an illustration of the applicable part location.

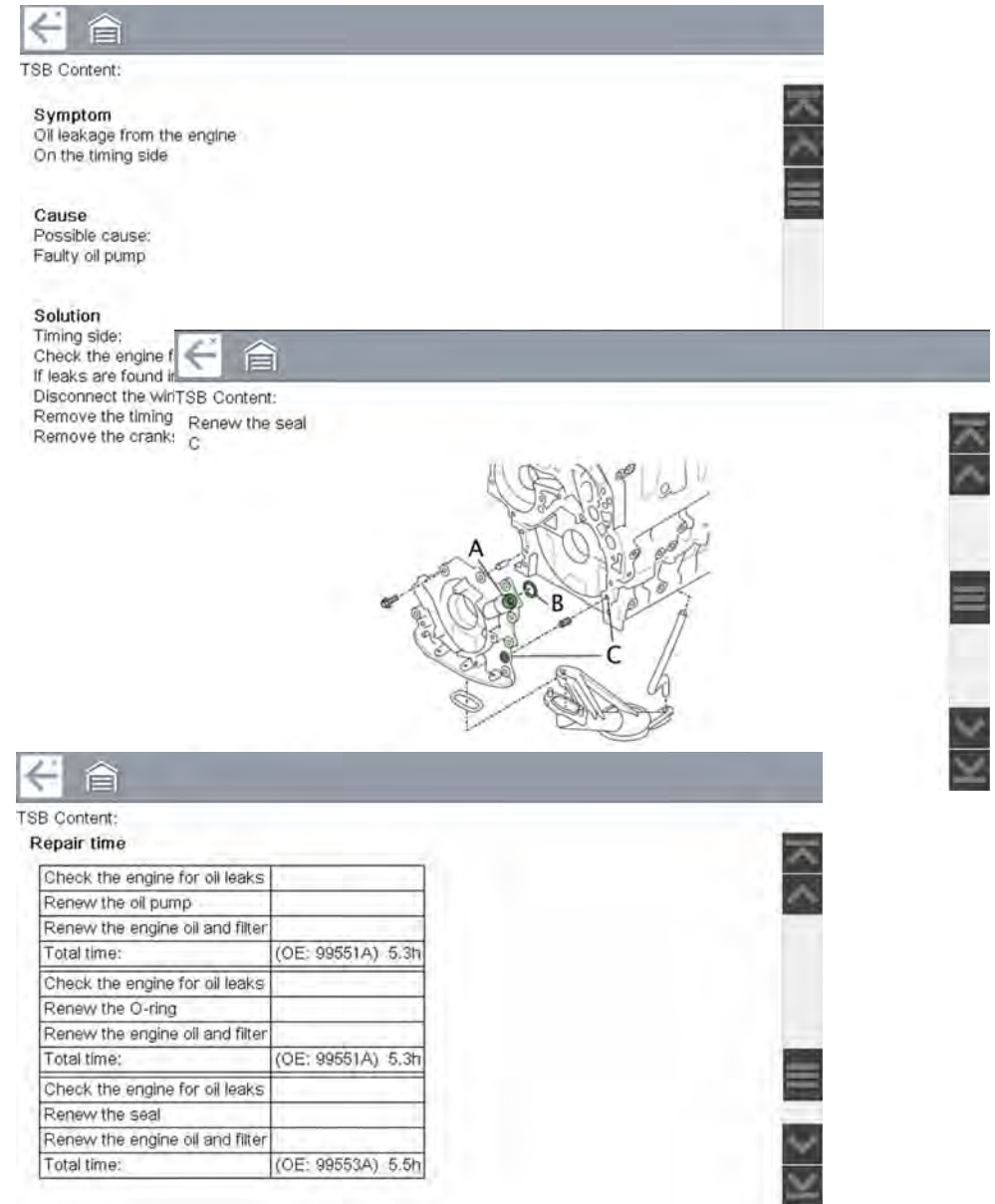

Figure 8-3 Typical - TSB

▶ Viewing TSBs (using Scanner)

1. From within a current Scanner session select **TSBs** from the System menu ([Figure 8-4](#)).

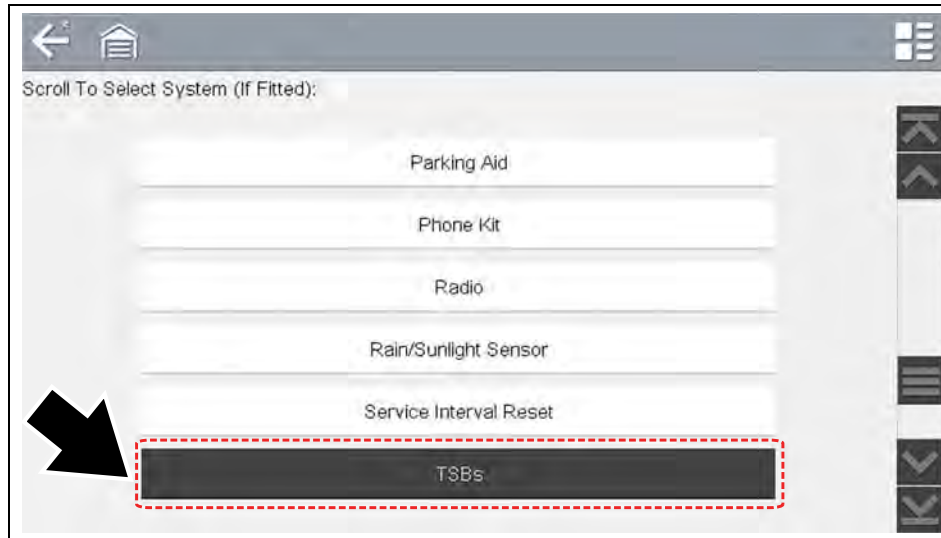

Figure 8-4 Scanner System Menu - TSBs Option

2. Select a vehicle area, (e.g. **Engine, Transmission, Brakes**, etc) ([Figure 8-5](#)).

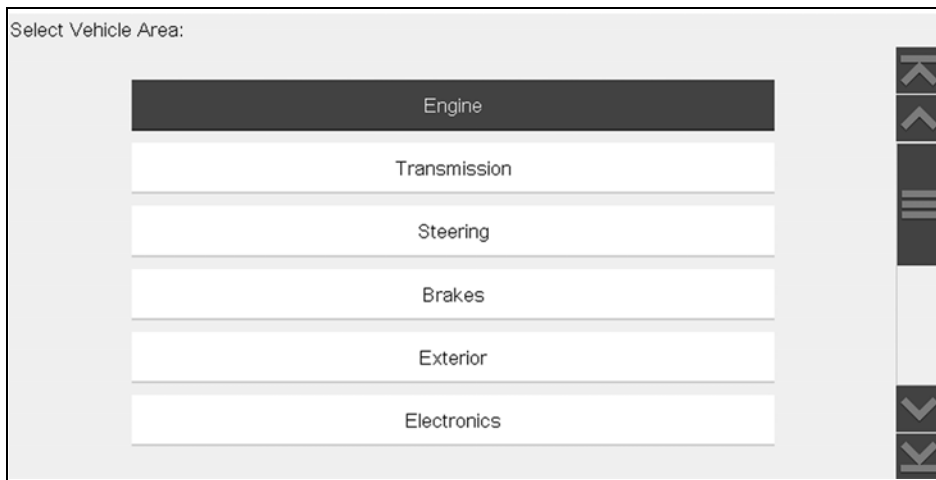

Figure 8-5 Vehicle Area Menu

3. Select the desired TSB.

If applicable, use the scroll bar or directional buttons (▲, ▼) to scroll up/down to view all of the information.

See TSB example in [Figure 8-3](#). The example, illustrates the typical sections of a TSB, the symptom, cause, solution, repair time, parts required, and shows an illustration of the applicable part location.



This section describes the basic operation of the OBD-II/EOBD function.



The **OBD-II/EOBD** icon is located on the Home screen.

The OBD-II/EOBD function allows you to access “generic” OBD-II/EOBD data.

Generic OBD-II/EOBD data is data limited to emission related diagnostics such as:

- Checking for emissions-related diagnostic trouble codes (DTCs)
- Checking the cause of an illuminated malfunction indicator lamp (MIL)
- Checking monitor status prior to emissions certification testing

To access other available electronic control module (ECM) data for vehicle specific systems, parameters or enhanced diagnostics use the Scanner function, see “Scanner” on page 12.

i NOTE

The OBD-II/EOBD function can also be used to access “generic” OBD-II/EOBD data for OBD-II/EOBD compliant vehicles that are not included in the Scanner function databases.

Main Topic Links

- [Basic Operations](#) page 59
- [OBD-II/EOBD Menu](#) page 60
- [OBD Health Check](#) page 60
- [OBD Direct](#) page 62
- [Connector Information](#) page 65
- [Manual Protocol Selection](#) page 65
- [Codes](#) page 60
- [Pending Codes](#) page 60
- [Readiness Monitors](#) page 63
- [MIL Status](#) page 63

- [Troubleshooter](#) page 63
- [\(\\$01\) Display Current Data](#) page 63
- [\(\\$02\) Display Freeze Frame Data](#) page 63
- [\(\\$03\) Display Trouble Codes](#) page 63
- [\(\\$04\) Clear Emissions Related Data](#) page 63
- [\(\\$05, 06, 07\) Display Test param./Results](#) page 64
- [\(\\$06\) On-board Monitored Systems](#) page 64
- [\(\\$07\) DTCs Detected During Last Drive](#) page 64
- [\(\\$08\) Request Control of On-board System](#) page 64
- [\(\\$09\) Read Vehicle Identification](#) page 64
- [\(\\$09\) In-use Performance Tracking](#) page 64
- [\(\\$0A\) Emission Related DTC with Permanent Status](#) page 65

9.1 Basic Operations

9.1.1 Screen Layout and Toolbar Controls

Screen layout and toolbar controls are similar to the Scanner function, see [Scanner Control Icons](#) on page 14.

9.1.2 Connecting the Data Cable

Connection of the data cable to the diagnostic tool and vehicle DLC is required for OBD-II/EOBD testing, see [Data Cable / Connections](#) on page 10.

9.1.3 Saving and Reviewing Data Files

Save and Pause control icon operation and data review procedures are the same as used for the Scanner function, see [Scanner](#) on page 12.



9.2 OBD-II/EOBD Menu

The following options are available from the OBD-II/EOBD menu:

- [OBD Health Check](#)
- [OBD Direct](#)

9.2.1 OBD Health Check

The OBD-II Health Check offers a way to quickly check for and clear emissions-related diagnostic trouble codes (DTCs), and to check readiness monitors for emissions testing. Selecting opens a connection message. Select **Continue** or press the **Y/✓** button to open a submenu of test options (*Figure 9-1*).



Figure 9-1 OBD Health Check menu

Global OBD II Code Check

Global OBDII Code Check displays stored emission related generic DTCs reported by the ECM. Selecting opens a submenu with two choices: Codes and Pending Codes. Either option opens a code list (*Figure 9-2*).

The DTC results screen is similar to the same screen used in the Scanner function, as both display the SureTrack results message below the toolbar. However, SureTrack is not accessible in OBD-II/EOBD mode. SureTrack is only accessible in the Scanner function where the vehicle has been identified.

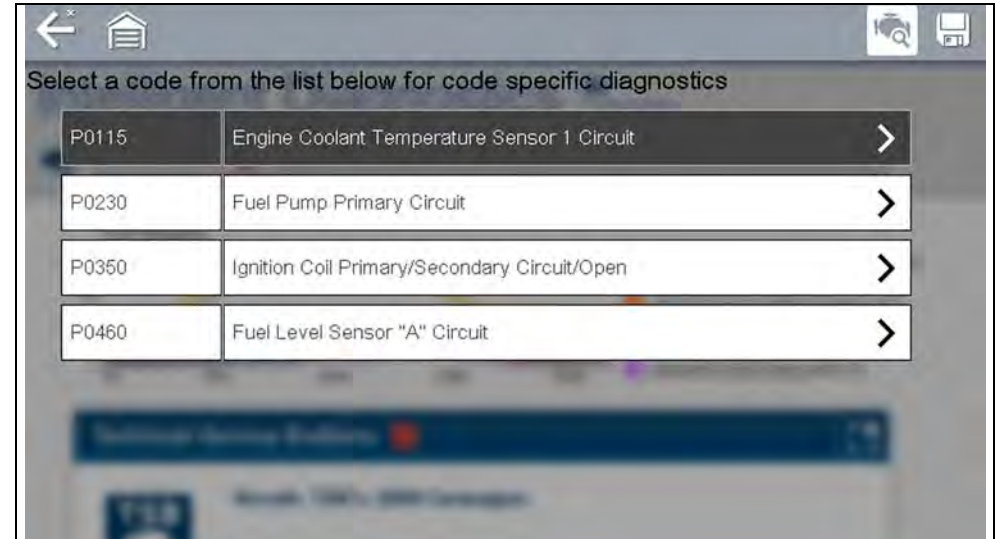

Figure 9-2 DTC Results Screen

Codes

The Codes option displays a list of current emission related DTCs.

OBD-II/EOBD Codes have a priority according to their emission severity. The priority of the code determines the illumination of the MIL and the code erase procedure. Vehicle manufacturers have implemented the ranking differently, so there are differences between makes.

Pending Codes

The purpose of this service is to enable the diagnostic tool to obtain “pending” or maturing diagnostic trouble codes. These are codes whose setting conditions were met during the last drive cycle, but need to be met on two or more consecutive drive cycles before the DTC actually sets.

NOTE

Save valuable time by using this service to verify test results after a single drive cycle following a vehicle repair and code clearing procedure.

- If a test failed during the drive cycle, the DTC associated with that test is reported. If the pending fault does not occur again within 40 to 80 warm-up cycles, the fault is automatically cleared from memory.
- Test results reported by this service do not necessarily indicate a faulty component or system. If test results indicate another failure after additional driving, then a DTC is set to indicate a faulty component or system, and the MIL is illuminated.

Refer to the [Global OBD Vehicle Communication Software Manual](#) for additional information.

Global OBD II Clear Codes

This option is used to clear all emission related diagnostic data, such as DTCs, freeze frame data, and test results, from the memory of the selected ECM. Although OBD-II/EOBD displays generic OBD-II/EOBD data only, clearing codes erases all of the stored data, including any enhanced codes and freeze frame information.

A confirmation screen displays when the clear codes option is selected to prevent accidental loss of data. Select to continue from the confirmation screen. Refer to the [Global OBD Vehicle Communication Software Manual](#) for additional information.

Readiness Monitors

This test checks the status of the readiness monitoring system. An OBD-II /EOBD control system runs continuous and periodic tests to check the status of emission-related subsystems to gauge the integrity of the electronic operations. Two options are available for Readiness Monitors:

- **Monitors Complete Since DTC Cleared**—displays the status of all monitors that have run since the last time ECM memory was erased.
- **Monitors Complete This Cycle**—displays the status of the monitors that ran during the current drive cycle only.

Selection of either option displays test results as shown in the data viewer ([Figure 9-3](#)).

Quick reference indicators are used to show monitor status on the left side of the screen ([Figure 9-3](#)):

- **Green icon “✓” mark** - Monitor test is complete
- **Gray icon “—” mark** - Monitor test is not complete
- **Red icon “X” mark** - Monitor test is not supported by vehicle

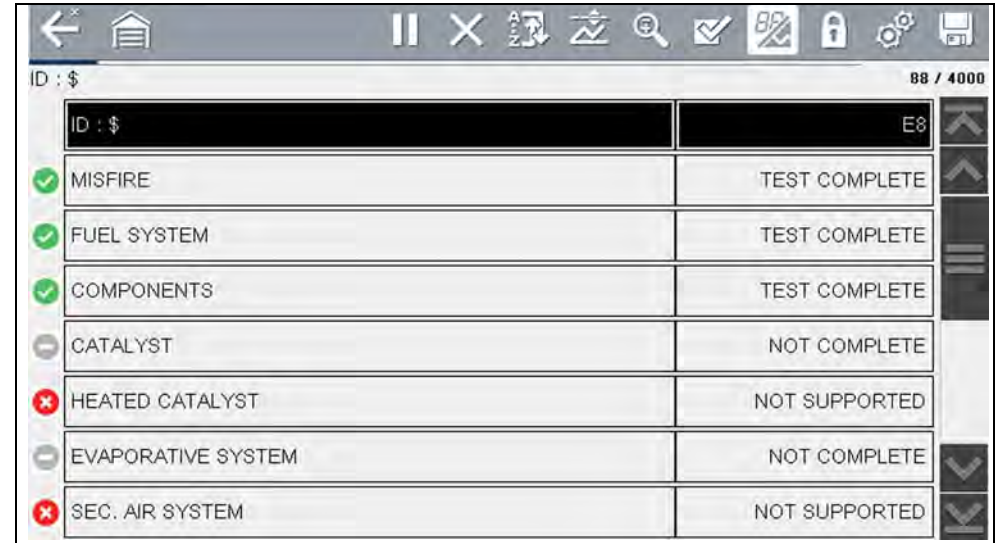

Figure 9-3 Readiness monitor test report

Use the scroll bar to view the entire list of Readiness Monitors.

Selecting **Save** from the toolbar saves the monitor data as an .SCM file for review at a later time. See [View Saved Data](#) on page 113 for additional information.

MIL Status

This test checks the ECM commanded state (on or off) if the malfunction indicator lamp.



9.2.2 OBD Direct

OBD Direct includes the following menu and submenu choices:

- **OBD Diagnose**
 - **Start Communication** - initiates a test session
 - **Connector Information** - provides DLC location details
 - **Manual Protocol Selection** - provides choices for communication protocol
- **OBD Training Mode** - allows you to familiarize yourself with the capabilities of OBD-II/EOBD while navigating through menus without being connected to a vehicle.

Start Communication

Use the following procedure to begin an OBD-II/EOBD test session:



To perform an OBD-II/EOBD Test:

1. Connect the data cable to the test vehicle.
2. Select **Start Communications** from the OBD-II/EOBD menu.

A series of messages are displayed indicating automatic detection of vehicle type (12 or 24 V) has occurred and then the detected controllers are displayed. The diagnostic tool establishes a communication link with the test vehicle, then opens an information screen (*Figure 9-4*).



Figure 9-4 Protocol information

The information screen shows how many control modules were detected, which ECM is communicating, and which communication protocol is being used.

3. Select **Continue**.

A Select Service menu of available tests opens:

- *Readiness Monitors* on page 63
- *MIL Status* on page 63
- *Troubleshooter* on page 63
- *(\$01) Display Current Data* on page 63
- *(\$02) Display Freeze Frame Data* on page 63
- *(\$03) Display Trouble Codes* on page 63
- *(\$04) Clear Emissions Related Data* on page 63
- *(\$05, 06, 07) Display Test param./Results* on page 64
- *(\$08) Request Control of On-board System* on page 64
- *(\$09) Read Vehicle Identification* on page 64
- *(\$09) In-use Performance Tracking* on page 64
- *(\$0A) Emission Related DTC with Permanent Status* on page 65

IMPORTANT

All service modes are not supported by all vehicles, so the available menu selections will vary.

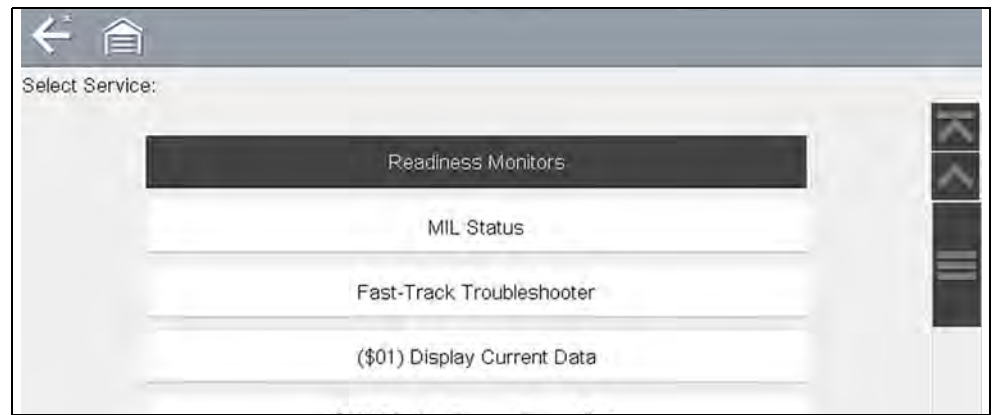

Figure 9-5 Service mode menu

4. Select a test to continue.



Readiness Monitors

Use this menu item to check the readiness of the monitoring system. Monitors not supported will display “not supported”. Scroll, if needed, to view the entire list of monitors ([Figure 9-3](#)). Selecting Readiness Monitors opens a submenu with two choices:

- **Monitors Complete Since DTC Cleared**—displays the results of all monitor tests that have run since the last time the vehicle electronic control module (ECM) memory was cleared.
- **Monitors Complete This Cycle**—displays only the results of monitor tests that ran during the current drive cycle, they reset when the ignition is switched off.

MIL Status

This item is used to check the current condition of the malfunction indicator lamp (MIL). Additional information, such as which ECM commanded the MIL on and the distance driven while the MIL is on (if supported), can also be displayed.

Troubleshooter

Troubleshooter is a database of experience-based repair strategies and information, that has been compiled and validated by top-notch technicians. The Troubleshooter system simplifies the diagnosis process, as it contains information on virtually all common diagnostic trouble code (DTC) problems and driveability symptoms for most vehicles covered by the vehicle communication software.

(\$01) Display Current Data

Use this test to display the serial data transmitted by the selected vehicle electronic control module (ECM). The main body of the screen has two columns; the left-hand column is a description of the parameter and the right-hand column is the parameter value or state. Viewing options and operations are the same as the Scanner function, see [Scanner](#) on page 12 for more information.

ID : \$		E8
ENGINE SPEED(1/min)		2033
ABSOLUTE THROTTLE POSITION(%)		16.5
ABSOLUTE THROTTLE POSITION B(%)		16.9
RELATIVE THROTTLE POSITION(%)		6.3
COMMANDED THROTTLE ACT.CONTROL(%)		6.7
ACCELERATOR PEDAL POSITION D(%)		15.7
ACCELERATOR PEDAL POSITION E(%)		7.5

Figure 9-6 Current data display

(\$02) Display Freeze Frame Data

Freeze frame data provides a “snapshot” of critical parameter values at the time a DTC set.

This item is used to display freeze frame data for any stored emission related diagnostic trouble codes (DTCs). In most cases the stored frame is the last DTC that occurred. Certain DTCs, those that have a greater impact on vehicle emissions, have a higher priority. In these cases, the highest priority DTC is the one for which the freeze frame records are retained.

(\$03) Display Trouble Codes

This is used to display any stored emission related DTCs reported by the ECM. The display is similar to the Scanner function code display (see [Codes - View / Save](#) on page 18 for details). The list does not include enhanced DTCs in this mode.

(\$04) Clear Emissions Related Data

This item is used to clear all emission related diagnostic data, such as DTCs, freeze frame data, and test results, from the memory of the selected ECM.

**To clear emission related Data:**

1. Select **Clear Emissions Related Data** from the menu.
A confirmation message displays to help prevent loss of any vital data (Figure 9-7).



Figure 9-7 Clear codes confirmation message

2. Continue from the confirmation message.
The screen updates several times as ECM memory is erased, then a “data has been cleared” message displays.
3. Select **Continue** to return to the Select Service menu.

(\$05, 06, 07) Display Test param./Results

This option opens a submenu of parameters and test results from various sensors, monitor test results, and a record of DTC setting conditions detected during the last drive cycle. The submenu includes:

- [\(\\$05\) Oxygen Sensor Monitoring](#)
- [\(\\$06\) On-board Monitored Systems](#)
- [\(\\$07\) DTCs Detected During Last Drive](#)

(\$05) Oxygen Sensor Monitoring

This option opens a menu of tests available for checking the integrity of the oxygen (O₂) sensors. Making a selection displays all of the pertinent O₂ sensor parameters for the specific test. The test identification (ID) displays at the top of the data list.

(\$06) On-board Monitored Systems

This option opens a menu of tests from the monitored systems. The available data is for specific systems and components that the on-board diagnostic system monitors continuously, such as misfire, or non-continuously, such as the catalyst system. Making a menu selection displays the test results.

(\$07) DTCs Detected During Last Drive

This test opens a record of any DTCs that set during the last completed drive cycle. Select to open the DTC list.

(\$08) Request Control of On-board System

This service enables bidirectional control of the ECM. This service allows the diagnostic tool to control the operation of an on-board system, test, or component.

(\$09) Read Vehicle Identification

The purpose of this service is to enable the diagnostic tool to request and display vehicle-specific information, such as the vehicle identification number (VIN), the calibration identification, and the calibration verification number (CVN), of the test vehicle. Select a menu item to retrieve the information. Select **Return** to go back to the menu.

(\$09) In-use Performance Tracking

This option displays the “In-use Performance Tracking” of data. It is a record of the number of times each of the monitor tests have been completed. Select **Return** to go back to the menu.



(\$0A) Emission Related DTC with Permanent Status

This option displays a record of any “permanent” codes. A permanent status DTC is one that was severe enough to illuminate the MIL at some point, but the MIL may not be on at the present time.

Whether the MIL was switched off by clearing codes or because the setting conditions did not repeat after a specified number of drive cycles, a record of the DTC is retained by the ECM. Permanent status codes automatically clear after repairs have been made and the related system monitor runs successfully.

Connector Information

This option opens a database of vehicle diagnostic connector locations that includes most makes and models. The menu driven interface leads you quickly to difficult to find test connectors.



To locate a vehicle diagnostic connector:

1. Select **Connector Information** from the System menu.
A list of vehicle manufacturers displays.
2. Select a manufacturer from the list.
A list of models available from the selected manufacturer displays.
3. Select a model from the list.
If a cable adapter is needed, which one and how to connect it displays.
4. Select **Continue**.
Information on where to locate the vehicle diagnostic connector displays.
5. Select **Continue** to return to the System menu.

Manual Protocol Selection

Communication protocol is a standardized way of transferring data between an ECM and a diagnostic tool. Global OBD may use the following communication protocols:

- ISO 15765-4 (CAN)
- ISO 27145 (WWHOBD CAN)
- ISO J1939 (CAN)
- ISO 9141-2 (K-LINE)
- SAE J1850 PWM (Pulse Width Modulation)
- SAE J1850 VPW (Variable Pulse Width)

- ISO 14230-4 (Keyword Protocol 2000)
- SAE J2284/ISO 15765-4 (CAN)

When initially attempting to establish communication with the ECM the diagnostic tool attempts to communicate trying each protocol in order to determine which one is being used. During normal operation the communication protocol is automatically detected. If automatic detection fails, communication protocol can be manually selected.

IMPORTANT

Using unsupported OBD communication protocols may activate warning lights and can set network related faults. Only use the manual selection option when OBD protocol is already known.

Select **Manual Protocol Selection** to open a menu of options ([Figure 9-8](#)).



Figure 9-8 Manual protocol selection menu

Select the **Back** icon or press the **N/X** button to return to the OBD-II/EOBD Main menu.



The Guided Component Tests function provides you with an extensive collection of vehicle specific component tests and reference information. It is like having access to a complete library of automotive repair manuals for testing multiple vehicle components.

The preconfigured meter tests and reference information provided are vehicle specific and designed to help save you diagnostic time, verify faulty components, and verify the repair.

Detailed instructions and reference information are provided to guide you through the testing process, from locating the component, to selecting the appropriate test, showing test lead connections, and illustrating electrical connector and pin configurations. In addition, test results (including waveform examples), procedures, tips, and specifications may also be provided.

i NOTE

Availability of tests and information may vary.

As an added resource, the Training and Classes feature provides even more support by including (non-vehicle specific) tests and resources that allow you to quickly perform common tests, review basic reference information and more.

Main Topic Links

- [Training and Classes](#) page 66
- [Screen Layout and Icons](#) page 69
- [Operation](#) page 69
- [Component Information](#) page 70
- [Tests](#) page 71
- [Saving and Reviewing Data Files](#) page 73

10.1 Training and Classes

Training and Classes is a companion feature to the Guided Component Tests function. This resource includes a wide collection of common (non-vehicle specific) reference information and tests, such as measuring fuel pump current ramp, and monitoring CKP and CMP signals simultaneously. Also included are, basic component operation and theory information, testing procedures, tips, definitions, illustrations, diagnostic tool feature descriptions and accessory information.



To access Training and Classes:

1. Select **Guided Component Tests** from the Home screen.
2. Select **Training and Classes** from the Vehicle Make menu ([Figure 10-1](#)) to access the menu options.

Each menu option is described in the following sections:

All features and information are subject to change. The following is for reference only.

- [Power User Tests](#)
- [Features and Benefits](#)
- [How To Guide](#)



Figure 10-1 Training and Classes



10.1.1 Power User Tests

Power User Tests provide you quick access to preconfigured meter tests for a number of common automotive system tests. Most tests provide onscreen help and testing information along with a description of the test and the expected results, including known good waveforms.

Here is a sample listing of the types and specific tests that may be available within Power User Tests:

- **Current Probe Tests** - provides common tests configured to use the Snap-on Low Amp Current probes or generic Low Amp Current probes. Snap-on Low Amp Current Probe operation information is also provided within the *Snap-on Low Amp Probe Reference Manual* option.
 - Fuel Injector Current Ramp (multiple types)
 - Fuel Pump Current Ramp
 - Fuel Pump RPM Calculation
 - Ignition Coil Current Ramp (multiple types)
 - Parasitic Draw
 - Snap-on Low Amp Probe Reference Manual
- **Dual Channel Tests** - provides common tests configured to measure or compare two signals
 - CAN-BUS High/Low
 - CKP and CMP Relationship
 - EGR Solenoid and Position Sensor
 - EVAP Solenoid and Diagnostic Switch
 - FlexRay Bus
 - Injector and Oxygen Sensor
 - Knock Sensor and EST
 - MC Dwell and Oxygen Sensor
 - Pre and Post Cat Oxygen Sensors
 - Throttle Positions 1 & 2
 - WSS (Hall Effect Type)
- **Transducer Tests** - provides common single and dual channel tests configured to measure various types of pressures, voltage and current. Transducers are available as optional equipment.
 - A/T Line Pressure and Shift Solenoid
 - A/T Line Pressure Test
 - EGR Temperature Sensor and EGR Vacuum
 - Exhaust Back Pressure Test
 - Fuel Pressure and Fuel Pump Current and Voltage
 - Fuel Pressure Test

10.1.2 Features and Benefits

Selecting **Features and Benefits** provides basic feature description and operational information about the diagnostic tool. Additional information is provided for ShopStream Connect, optional waveform demonstration boards and optional accessories. Selections include:

- **5-Minute Walk Thru With Demo Board**—provides instructions on the operation of the optional waveform demonstration board(s) to sharpen your Lab Scope and Meter skills. Topics may include:
 - New Demo Board (PN) #EESX306A—provides functionality information and basic step-by-step demonstration information of multiple generated waveforms
 - Old Demo Board (PN) #SSP816—provides functionality information and basic step-by-step demonstration information for multiple generated waveforms

The optional demonstration board(s) generate various waveforms similar to signals commonly found on modern vehicle control systems. The demonstration board(s) not only help you learn how to use the Guided Component Tests software, it allows you to hone your skills and diagnostic techniques without connecting to an actual vehicle. Contact your sales representative for details.
- **Accessories**—provides descriptions for the optional accessories available for the diagnostic tool. Accessory topics may include:
 - Low Amp Probe
 - Pressure/Vacuum Transducers
 - ShopStream Connect
 - Test Leads and Clips
- **Product Description**—provides an overview of diagnostic tool capabilities and operations.



10.1.3 How To Guide

The **How To** option provides multiple topics and references ranging from instructional and basic theory to troubleshooting and testing instructions. Menu options may include:

- **10-minute Electronic Classes**—provides basic electrical theory and testing information. Topics may include:
 - Ohm's Law
 - Variable Resistors
 - Amperage
 - Diode Continuity
 - Electrical Circuits
 - Guided Voltage Drop Test
 - Other Electrical Measurements
 - Resistance
 - Scientific Notation
 - Voltage
- **15-minute Ignition Class**—provides basic introductory ignition system information. Topics may include:
 - Introduction
 - Coil on Plug (COP)
 - Conventional
 - Waste Spark
- **Illustrated Terms & Definitions**—provides common term definitions, illustrations and tips associated with automotive component testing.
- **No-Start Basics**—provides basic step-by-step procedures for the diagnosis of a no-start condition on carbureted and fuel injected vehicles.
- **O2 Sensor & Feedback System Analysis**—provides basic definition and theory information for the following O2 sensor topics:
 - Air Fuel Ratio Sensors
 - Correct PCM Response (includes configured meter test)
 - Heated Oxygen Sensor
 - Non-Heated Oxygen Sensor
 - Open and Closed Loop
 - Oxygen Sensor Types
 - Understanding Oxygen Sensors (includes configured meter test)
- **Snap-on Automotive Theory**— provides basic theory information on multiple topics including:
 - Air Conditioning
 - Diagnosing Battery Draws

- Diesel Particulate Filters
- Electronic Parking Assistance
- HID Headlights
- Hybrid Vehicles
- LIN-BUS
- Supplemental Restraint Systems
- Tire Pressure Monitoring (TPMS)
- **Test Tips**—provides basic testing information, tips and procedures for specific tests and meter operations. Topics may include:
 - Alternator Ripple Test
 - EVP Sensor Test
 - Frequency, Pulse Width and Duty Cycle Test
 - Graphing AC Voltage
 - Injector Pulse Width Test
 - Parasitic Draw Test
 - Reading Pulsed DTC's
 - TPS Sweep Test
 - Using Cursors
 - Using Pressure Transducers
 - Using Triggers
 - Wiggle Test
 - Zirconia Oxygen Sensor Rise Time
- **Theory and Operation**—provides basic theory information for the following topics:
 - Oxygen Sensors
 - Relays
- **20-minute Current Ramp Classes**—provides an introduction to current ramp testing using the Snap-on Low Amp Current Probes. Snap-on Low Amp Current Probe operation information is also provided within the *Snap-on Low Amp Probe Reference Manual* option. Topics may include:
 - Fuel Injector Current Ramp (multiple types)
 - Fuel Pump Current Ramp
 - Fuel Pump RPM Calculation
 - Ignition Coil Current Ramp (multiple types)
 - Parasitic Draw
 - Snap-on Low Amp Probe Reference Manual
 - Using Fuse Box for Current Test Hard to Reach Wiring

10.2 Screen Layout and Icons

This section describes the Guided Component Tests control icon functions and screen layout.

10.2.1 Screen Layout



- 1— **Vehicle Identification**
- 2— **Toolbar**—contains control icons
- 3— **Main Body**—displays menus, information, meter scales and signal traces
- 4— **Information Panel**—displays test information
- 5— **Expand/Collapse icon**—toggles Main body view between full and split views

Figure 10-2 Test screen

Main Body

The main body of a Guided Component Test screen may display any of the following:

- **Selectable Menu** - Select menu options using the touch screen or control buttons.
- **Component Information** - Provides information to assist you with testing.
- **Test Meter** - The test meter can display up to two signals, simultaneously. Signal and display adjustments are made through the Control Panel. Signals are displayed using a grid with scales, both vertical (y axis), and horizontal (x axis).

Meter touch screen functionality is limited, however you can adjust the zero baseline position (0 value) of the signal on the horizontal scale by touching and dragging the zero baseline marker.

10.2.2 Guided Component Tests Control Icons

Guided Component Tests toolbar control icons may vary depending on the active function or test. A frame surrounding an icon (highlighted), indicates it is selected. See control icons descriptions in [Scope Multimeter Control Icons on page 82](#) and [Common Toolbar Control Icons on page 8](#).

10.3 Operation

As the information and tests provided within the Guided Component Test function is vehicle specific, the vehicle must first be identified in order to retrieve the correct data.



To identify a vehicle:

The vehicle identification process is the same as the process used for the Scanner function, see [Vehicle Identification on page 15](#) for additional information. Once the vehicle is identified, a list of Systems is displayed.



To select a system and component to test:

1. Select a system from the list ([Figure 10-3](#)).

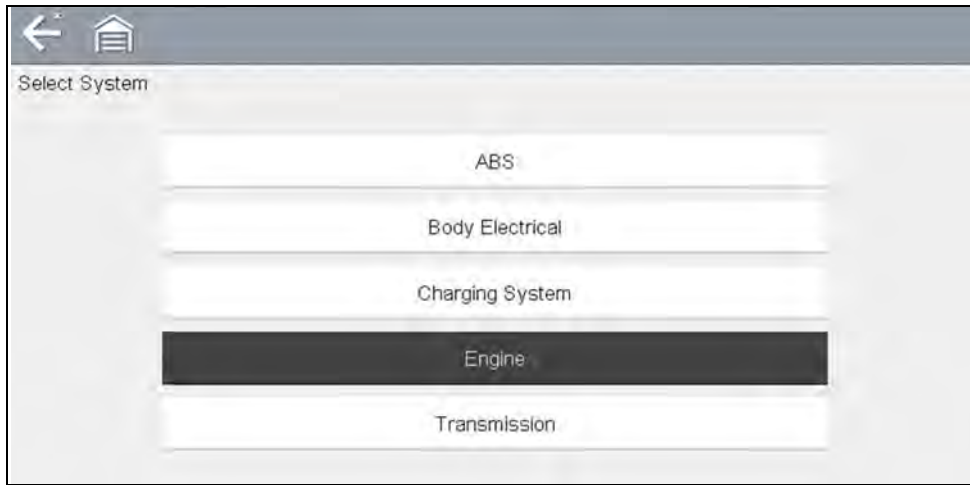

Figure 10-3 Systems Menu

A list of Components (and/or sub systems) is displayed (Figure 10-4).

2. Select a Component to continue.

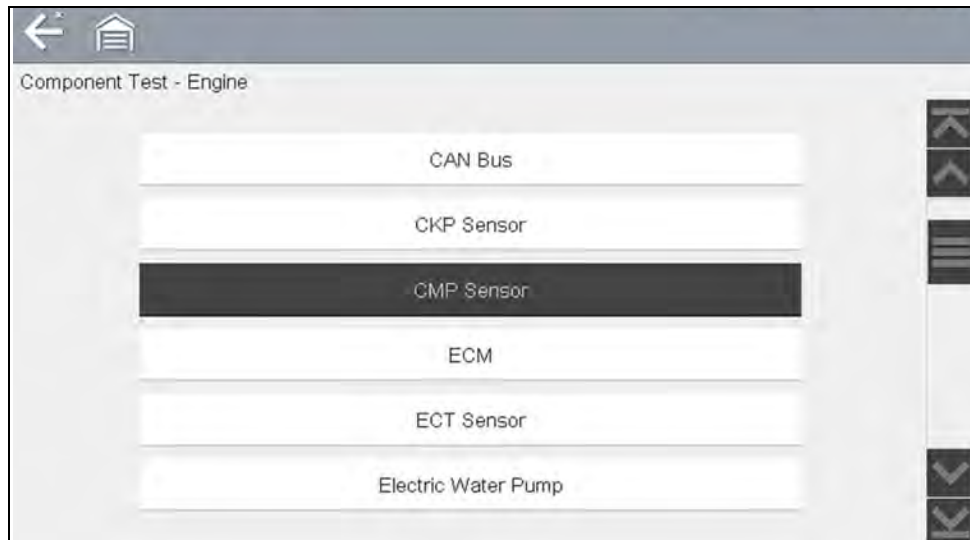

Figure 10-4 Component Menu

Depending on the vehicle and component selected, different options and sub-menus may be displayed. Information and tests may vary:

- **Component Information**— see [Component Information](#) on page 70.
- **Tests**— see [Tests](#) on page 71.
- **Reference Information**—provides identification of components, connector pin location and functions, and abbreviation reference.

10.3.1 Component Information

Component Information provides (if available) specific operational information on the selected component, and may also include electrical connector and pin location and function details



To view component information:

1. Select a component.
2. Select **Component Information** from the Component Test menu (Figure 10-5).

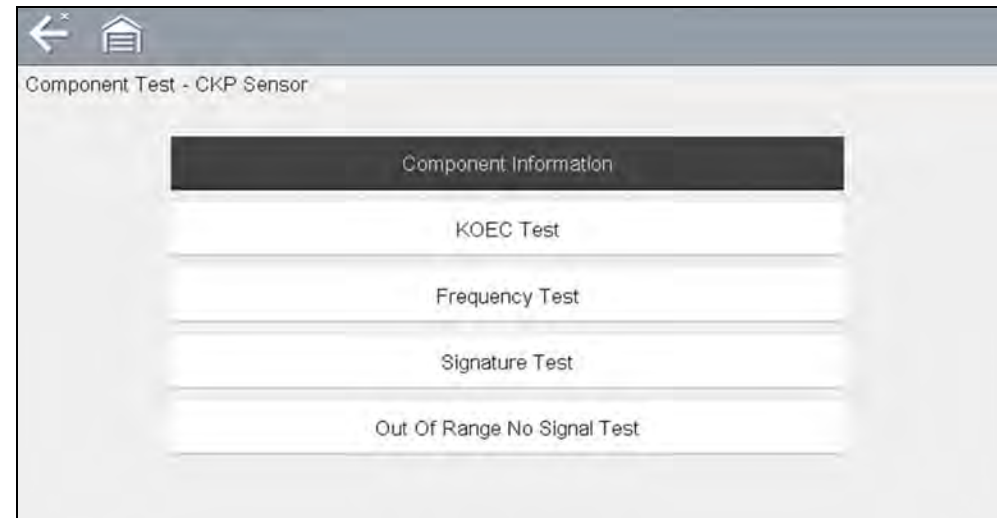

Figure 10-5 Component Tests Menu

i NOTE

An additional selection may be required for some components (e.g. selecting front or rear for an oxygen sensor (O2S)).

Component Information is displayed (*Figure 10-6*).

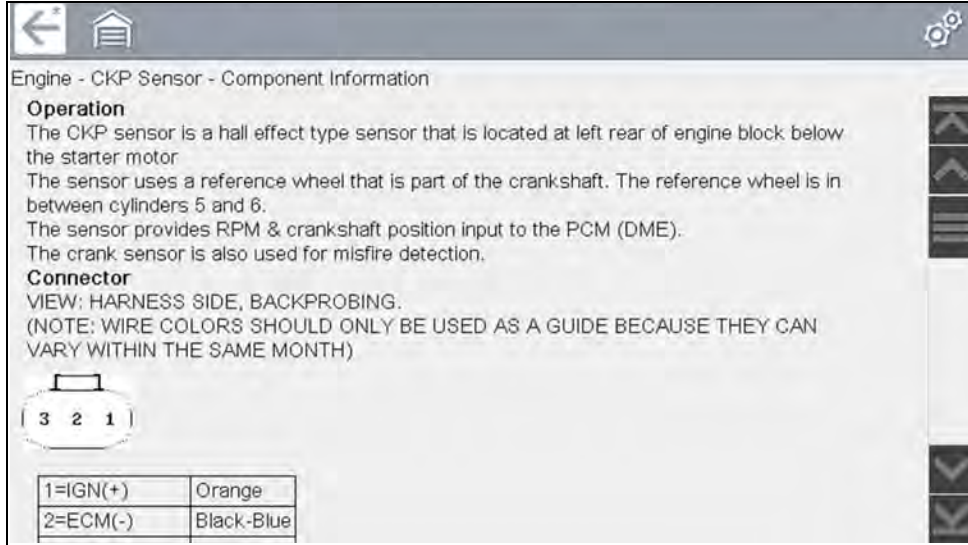

Figure 10-6 Component Information Screen

Screens are divided into sections to quickly guide you to the correct information (available sections and information will vary):

- **Operation**—provides a general description of component operation.
- **Tech note**—provides component related tips (e.g. common failures or faults), additional information may include OEM service updates and recall information.
- **Connector**—displays illustrated electrical connectors and socket/pin identification.
- **Location**—provides component locations, testing tips, and alternate testing locations if available.

Use the scroll bar to view additional information.

3. Select **Back** on the Toolbar, or press the **N/X** button, to return to the component menu.

10.3.2 Tests

Tests provides (if available) specific instructions to help you perform tests on components. Selecting a component test opens a preconfigured meter to start the test, and may also provide connection instructions, specifications and testing tips.

▶ To select a test:

1. Select a component.
2. Select a **Test** from the Component Test menu (*Figure 10-7*).

The component test menu lists all of the tests available for the selected component. Choices vary by the type of component, as well as the make, model, and year of the vehicle.

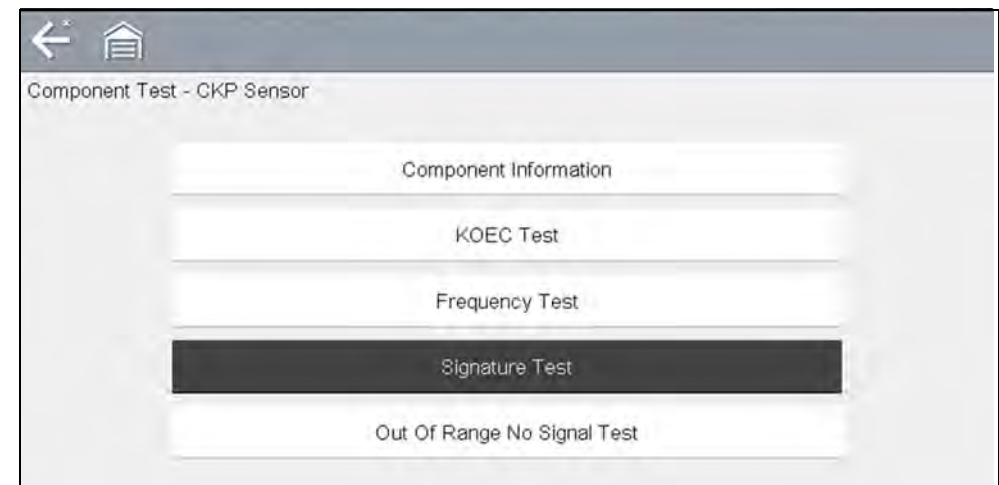

Figure 10-7 Component Test Menu

❗ NOTE

An additional selection may be required for some Component Tests (e.g. selecting front or rear for an oxygen sensor).



The test screen displays (Figure 10-8).

A Guided Component Test screen initially opens with the information panel below the main body. Use the scrollbar to display hidden information.

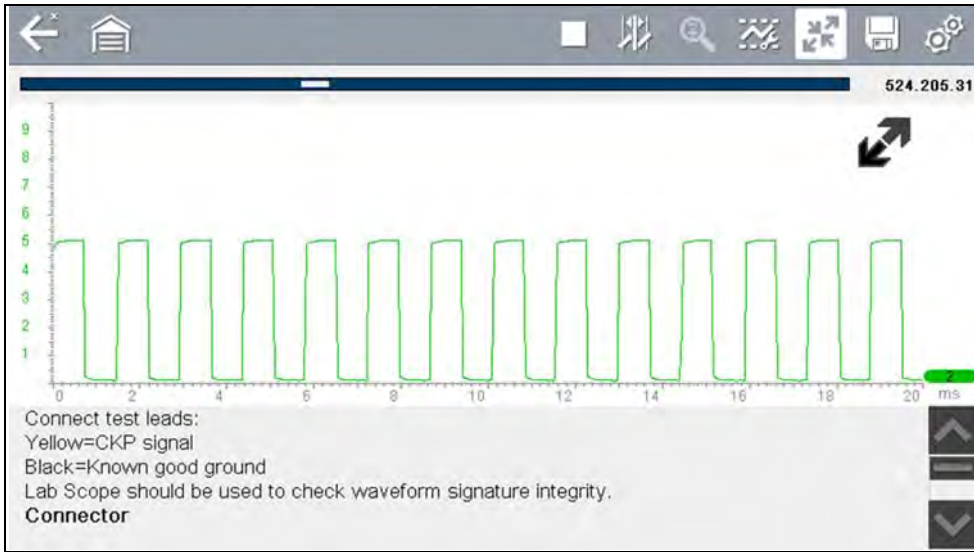

Figure 10-8 Test screen

3. Tap on the Information Panel once to display the information panel in full screen view. Tap on it again to return to split view. The **Expand/Collapse** icon can also be used to toggle through split and full screen views (Figure 10-9).

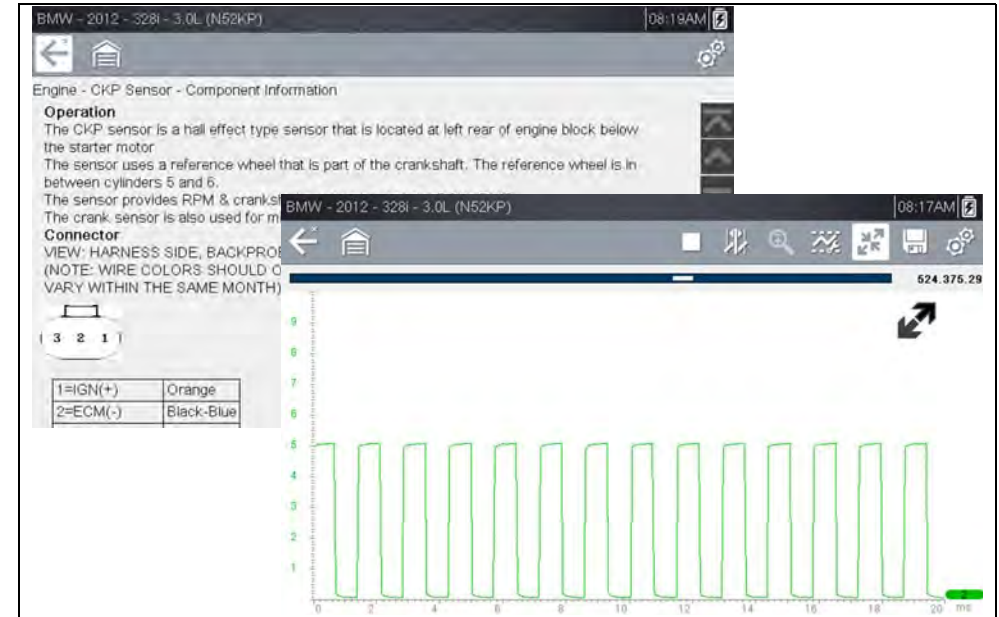

Figure 10-9 View Options

Some tests (e.g. signature integrity tests) may include waveform examples within the information panel. These waveform examples allow you to compare your test results for quick diagnosis (Figure 10-10).

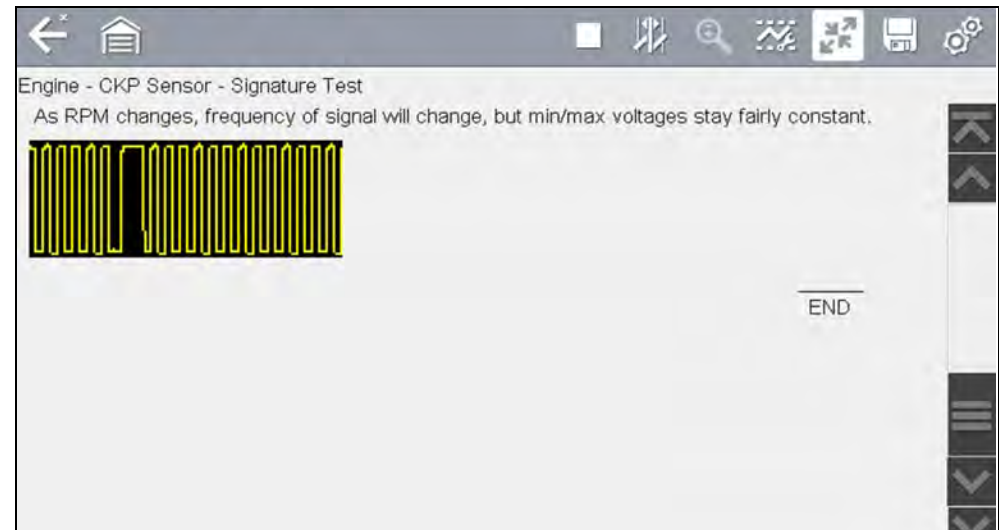

Figure 10-10 Waveform Example

4. Select **Back** on the toolbar to return to the menu.

Channel Settings

The test meter is preconfigured, for most of the component tests. However, if the need to change channel settings is needed, adjustments can be made by selecting the **Control Panel** icon from the toolbar to display the Control Panel ([Figure 10-11](#)). For additional information on channel settings, see [Control Panel and Settings on page 84](#).



Figure 10-11 Control Panel - Channel Controls

10.3.3 Saving and Reviewing Data Files

Save and Stop control icon operation and data review procedures are the same as used for the Scope/Multimeter function, see [Saving Data Files on page 105](#).



The Scope Multimeter function allows you to perform multiple types of circuit and component measurement tests. This chapter includes general operation procedures, instructions for saving and reviewing test data, optional settings, and general reference information.

Main Topic Links

- [Safety Information](#) page 74
- [Overview](#) page 75
- [Digital Multimeter \(DMM\)](#) page 75
- [Graphing Multimeter \(GMM\)](#) page 76
- [Lab Scope](#) page 77
- [Digital Multimeter \(DMM\)](#) page 75
- [Tests and Capabilities \(Quick Reference\)](#) page 78
- [General Information](#) page 81
- [Operation and Controls](#) page 83
- [Optional Settings](#) page 97
- [Capturing Data](#) page 101
- [Optional Settings](#) page 97
- [Reviewing Data and Using Zoom \(Review Mode\)](#) page 102
- [Saving Data Files](#) page 105
- [General Reference](#) page 106

11.1 Safety Information

IMPORTANT

Over Voltage Installation Category (CAT) - This Scope Multimeter is rated as a Category (CAT) 1 device. The maximum rated transient over voltage impulse is 500 volts, DO NOT exceed the rated transient over voltage.



! WARNING

Risk of electrical shock.

- **Read the Safety Information** provided for important warnings on the use of this product
- **This product is intended for Measurement Category I** (for example, automotive 12V systems), do not use this product for Measurement Categories II, III, and IV.
- **Measurement Category I** is for performing measurements on circuits not directly connected to MAINS or MAINS circuits (an example of a MAINS circuit is 120V AC or 240V AC household or industrial electricity), do not connect this product to MAINS or MAINS circuits.
- **Do not apply the Black Ground Lead** to test points other than ground/system return/vehicle chassis.

Electrical shock can cause personal injury, equipment damage, and/or circuit damage.

11.1.1 Measurement Out of Range Indicator

A group of arrows display when a measurement is out of range for the scale selected:

- Arrows pointing UP—measurement over maximum range
- Arrows pointing DOWN—measurement under minimum range

Voltage measurements also display arrows in place of live values when the voltage exceeds the input rating of the meter.

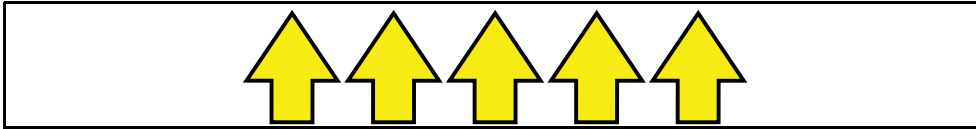

Figure 11-1



WARNING

Risk of electrical shock.

- **Do not exceed voltage limits between inputs as indicated on the rating label.**
- **Use extreme caution when working with circuits that have greater than 40 volts AC or 24 volts DC.**

Electrical shock can cause personal injury, equipment damage, and/or circuit damage.

IMPORTANT

If arrows are displayed in the live voltage values, discontinue circuit testing.

Correct an out-of-range condition by selecting a scale setting appropriate for the signal being sampled. See [Scale \(Vertical scale adjustment\)](#) on page 85 for more information.

11.2 Overview

The Scope Multimeter test functions are:

- Digital Multimeter (DMM)
- Graphing Multimeter (GMM)
- Lab Scope

IMPORTANT

Over Voltage Installation Category (CAT) - This Scope Multimeter is rated as a Category (CAT) 1 device. The maximum rated transient over voltage impulse is 500 volts, DO NOT exceed the rated transient over voltage.

11.2.1 Digital Multimeter (DMM)

The digital multimeter gives you the ability to quickly make precise common electrical measurements (e.g. DC and AC voltage, resistance and amperage) on circuits and components to verify operation. The meter displays measurements in a digital numerical format, and is typically used for measuring signals that are not rapidly changing.

The DMM is ideal for performing basic tests on most standard automotive circuits, and displays the results in a large easy to see format.

To use the DMM, select the **Scope Multimeter** icon from the home screen then select **Digital Multimeter** from the menu. See [Tests and Capabilities \(Quick Reference\)](#) on page 78 for a list of available testing functions.

Specifications

Function	Range	Accuracy/Comments
Signal Measurement	Ch. 1— (yellow jack)	Input is referenced to common ground (GND— (black jack)
VDC (Full Scale)	75VDC	Do not measure greater than 75VDC
VAC (Full Scale)	50VAC	Do not measure greater than 50VAC (rms)
Signal Measurement Input Impedance	10 MΩ	-
Ohm Measurement	Ch. 1— (yellow jack (-)) Ch. 2— (green jack (+))	-
Diode Test		
Continuity Test		
Ohms	40 Ω—4 MΩ	Fixed scales or auto ranging
Glitch Capture	Approximately 50 μS	-
Diode test	2V scale	-



11.2.2 Graphing Multimeter (GMM)

Unlike the DMM, the graphing multimeter provides two channels for testing and plots a visual graphing line of the signal instead of displaying digital values. The GMM displays a signal's measurements over time on a two-dimensional grid. This plotted graph is basically a graphical history (histogram) of the signal's measurements over time.

The GMM uses a higher sample rate (than a DMM) to calculate signal measurements. This characteristic along with the visual graph, make the GMM ideal for finding intermittent dropouts or glitches that may not be obvious when viewing a digital value. A key advantage of the GMM is being able to capture a signal over a long time interval and then review it's graphical history, to visually see if and when dropouts have occurred.

In addition, the GMM uses a combination of filter and peak detect modes to provide a good balance between detecting fast glitches and preventing unwanted noise from displaying.

Unlike the lab scope, the sweep scales used with typical GMM tests are of longer time intervals, and may range from seconds to minutes, compared to the lab scope sweep scales that use relatively short time intervals (e.g. milli and micro seconds). This allows you to monitor a signal over a longer period of time when looking for erratic glitches or dropouts.

To use the GMM, select the **Scope Multimeter** icon from the home screen then select **Graphing Multimeter** from the menu. See [Tests and Capabilities \(Quick Reference\)](#) on page 78 for a list of available testing functions.

Specifications

Function	Range	Accuracy/Comments
Signal Measurement	Ch. 1— (yellow jack) Ch. 2— (green jack)	Each channel input is referenced to common ground (GND— black jack)
Sample Rate	1.5 MSPS	Continuous sampling, MSPS = mega samples per second
Band Width	3 MHz	3 db point @ 3 MHz
Input Impedance	10 M Ω @ DC 4 k Ω @ 3 MHz	Channel 1 and 2
VDC (Full Scale)	75VDC	Do not measure greater than 75VDC
VAC (Full Scale)	50VAC	Do not measure greater than 50 VAC (rms)
Ohm Measurement Diode Test Continuity Test	Ch. 1— (yellow jack (-)) Ch. 2— (green jack (+))	-
Ohms	40 Ω —4 M Ω	Fixed scales
Low Amp Probe	20A scale (100mV/Amp) 40A scale (10mV/Amp) 60A scale (10mV/Amp)	Connect the positive (+) Amp Probe lead to the yellow jack on the diagnostic tool for values on Ch.1, or to the green jack for values on Ch. 2. Connect the negative (-) lead to GND (black jack) ¹ .
1. Do not use the Low Amp Probe to measure current on conductors at a potential greater than 46VAC peak or 70VDC.		



11.2.3 Lab Scope

Similar to the GMM, the lab scope (oscilloscope) plots a visual image line of a signal's measurements over time on a two-dimensional grid. The visual line that is displayed is commonly called a trace, and the graphical form created by a signal is called a waveform.

Unlike the DMM, the lab scope allows you to visually see a signals waveform, which in turn allows you to see the strength and shape of the signal, as well as any noise that may be occurring on the circuit. The lab scope also samples signals at a high rate, which allows you to see a higher level of detail in short samples of the signal, especially in signals that change rapidly. In addition, the lab scope also provides more control over the acquisition of the signal and in how it is displayed, through the use of triggers and channel controls. All of these features allow you to analyze signals in great detail when performing diagnostics.

To use the lab scope, select the **Scope Multimeter** icon from the home screen then select **Lab Scope** from the menu. See [Tests and Capabilities \(Quick Reference\)](#) on page 78 for a list of available testing functions.

Specifications

Function	Range	Accuracy/Comments
Signal Measurement	Ch. 1— (yellow jack) Ch. 2— (green jack)	Each channel input is referenced to common ground (GND— black jack).
Sample Rate	For 50 μ S sweep 6 (MS/s) For 100 μ S sweep 3 (MS/s) For all other sweeps 1.5 (MS/s)	Continuous sampling, (MS/s) = mega samples per second
Band Width	3 MHz	3 db point @ 3 MHz
Input Impedance	10 M Ω @ DC 4 k Ω @ 3 MHz	Channel 1 and 2
VDC (Full Scale)	100mV–400V	Do not measure greater than 75VDC.
VAC (Full Scale)	100mV–400V	Do not measure greater than 50 VAC (rms).
Low Amp Probe	20A scale (100mV/Amp) 40A scale (10mV/Amp) 60A scale (10mV/Amp)	Connect the positive (+) Amp Probe lead to the yellow jack on the diagnostic tool for values on Ch.1, or to the green jack for values on Ch. 2. Connect the negative (–) lead to GND (black jack) ¹ .
1. Do not use the Low Amp Probe to measure current on conductors at a potential greater than 46VAC peak or 70VDC.		



11.3 Tests and Capabilities (Quick Reference)

The following chart identifies and describes available tests by function.

i NOTE

Not all the tests listed are described in this manual. This list is intended as reference only.

D M M	G M M	L S	Test	Function
		✓	Two Channel Lab Scope	Displays two Lab Scope channels automatically.
	✓		Dual Graphing Meter	Displays two Graphing Multimeter channels automatically.
		✓	Ignition Probe	Measures secondary Ignition voltage 2 to 50kV. Displays secondary ignition (kV) waveforms.
✓	✓	✓	Volts DC	Measures direct current voltage. DC voltage is measured through the two test leads connected to a DC circuit.
✓	✓		Volts DC - Average	Measures DC voltage using a filter to determine the average voltage over a period in time. DC voltage is measured through the two test leads connected to a DC circuit.
✓	✓		Volts AC RMS	Measures the effective AC voltage, not the peak voltage which results in measurements with higher accuracy. The AC RMS (root mean square) voltage value can be defined as the equivalent DC voltage of the AC voltage measured. RMS values are commonly used in AC electrical measurement, as they are more representative of DC measurements.
✓	✓		Ohms	Measures electrical resistance (opposition to current) 0 to 4 M Ohms. Scope supplied DC current is passed through the circuit to measure the resistance between the two connected test leads.

D M M	G M M	L S	Test	Function
✓			Diode/Continuity	Measures voltage drop across a diode and continuity through a diode. Scope supplied DC current is passed through the diode to measure the voltage drop between the two connected test leads. Typical setup for positive to negative current flow - positive lead (anode +/side) and negative (cathode -/side).
	✓		Frequency	Measures the number of times a signal repeats itself per second. Used to measure frequency of signals such as CKP, CMP and wheel speed sensors.
	✓		Pulse Width	Measures the on-time of various components (e.g. components that cycle on and off like the EGR, or canister purge).
	✓		Injector Pulse Width	Measures fuel injector on-time when checking for variances when engine load is changed and/or physical problems with the injector.
	✓		Duty Cycle	Measures the ratio of the pulse width to the complete cycle width, the on-time of components that cycle on and off like EGR, or canister purge from 0–100%.
✓	✓	✓	Low Amps (20)	Used to measure amperage of typical devices (e.g. ignition coils, injectors, fuel pumps) that may draw up to 20A peak (startup) when initially started. Also used to measure parasitic draw.
✓	✓	✓	Low Amps (40)	Used to measure amperage of typical motors and devices that may draw up to 40A peak (startup) when initially started.
✓	✓	✓	Low Amps (60)	Used to measure amperage of larger motors and devices that may draw up to 60A peak (startup) when initially started.
	✓		MC Dwell (60)	Measures carburetor Mixture Control Solenoids (0–60°). The duty cycle of the solenoid is expressed in the dwell angle of a 6 cylinder engine: 100% = 60 deg.
	✓		MC Dwell (90)	Measures fuel system Mixture Control Solenoids (0–90°). The duty cycle of the solenoid is expressed in the dwell angle of a 4 cylinder engine: 100% = 90 deg.
	✓	✓	100 PSI Vacuum	Used to measure vacuum up to 20 in.Hg, using the 0–100 psi transducer.

D M M	G M M	L S	Test	Function
	✓	✓	100 PSI Pressure	Used to measure pressures for typical systems such as, fuel, oil, EVAP, hydraulic/transmission fluid etc. up to 100 psi, using the 0–100 psi transducer.
	✓	✓	500 PSI Pressure	Used to measure pressures for typical systems such as, hydraulic/transmission fluid pressure, cylinder compression, and AC high side up to 500 psi, using the 0–500 psi transducer.
	✓	✓	5000 PSI Pressure	Used to measure pressures for typical systems such as, ABS, power steering, and heavy-duty hydraulic system fluid up to 5000 psi, using the 0–5000 psi transducer.
	✓	✓	MT5030 Vacuum	Used to measure vacuum up to 29 in.Hg, using the MT5030 pressure transducer adapter.
	✓	✓	MT5030 Pressure	Used to measure fluid and gas pressures up to 500 psi, using the MT5030 pressure transducer adapter.
	✓	✓	EEDM506D Temperature	Used to measure temperatures from -50° to 1800° F (-45 to 982° C), using the EEDM506D pressure transducer adapter.

11.4 Test Leads and Accessories

Some of the leads, probes and adapters supplied with or that may be available, are explained in the following section.

NOTE

Not all test leads and/or accessories may be available in all markets. Contact your sales representative for information, or to find out more about these and other available accessories.

IMPORTANT

Avoid damaging test leads, do not pull on the wire when removing the leads from their jacks. Pull only on the lead terminal end.

11.4.1 Channel 1 Lead

The shielded yellow lead is used with channel 1, and is color matched with the channel 1 jack on the diagnostic tool.

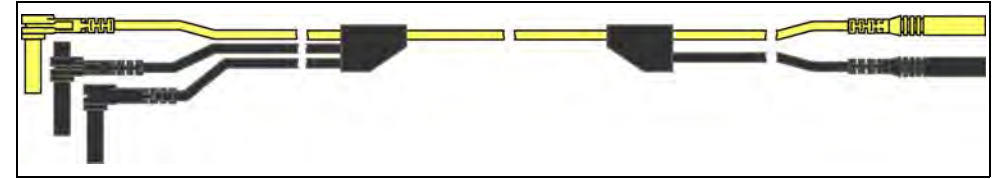

Figure 11-2 Yellow Channel 1 Lead

This lead also includes two black, right-angle common ground plugs. One plug is standard and the other is stackable. The standard ground plug should always be connected to the ground (GND) jack on the diagnostic tool.

The stackable ground plug is used for connecting additional ground leads, such as the Channel 2 or the Secondary Coil Adapter lead grounds. The stackable ground lead is internally connected to the standard ground lead, therefore it does not need to be connected to the diagnostic tool ground jack.

11.4.2 Channel 2 Lead

The shielded green lead is used with channel 2, and is color matched with the channel 2 jack on the diagnostic tool. This lead also includes a black, right-angle stackable ground plug.



Figure 11-3 Green Channel 2 lead

11.4.3 Alligator Clips and Probes

Insulated alligator clips and probes (pointed type) can be attached to the end of the test leads. Each alligator clip is color matched with a test lead, and the probes are available in red and black.

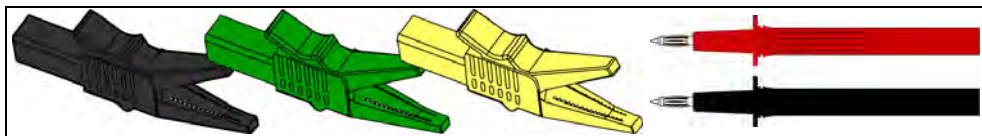

Figure 11-4 Alligator clips

11.4.4 Secondary Ignition Coil Adapter Lead and Clip-on Adapter (optional)

The secondary ignition adapter lead can be used with the secondary ignition clip-on wire adapter, coil-in-cap (CIC), or coil-on-plug (COP) secondary ignition adapters to display secondary ignition signals. The clip-on adapter clips over a secondary ignition wire to pickup a signal, and the CIC and COP adapters attach to the ignition coil. The coil adapter lead includes a black, right-angle stackable ground plug, and a RCA type connector that is used to connect the lead to a secondary ignition adapter. The spring clamp is used to connect to a ground.

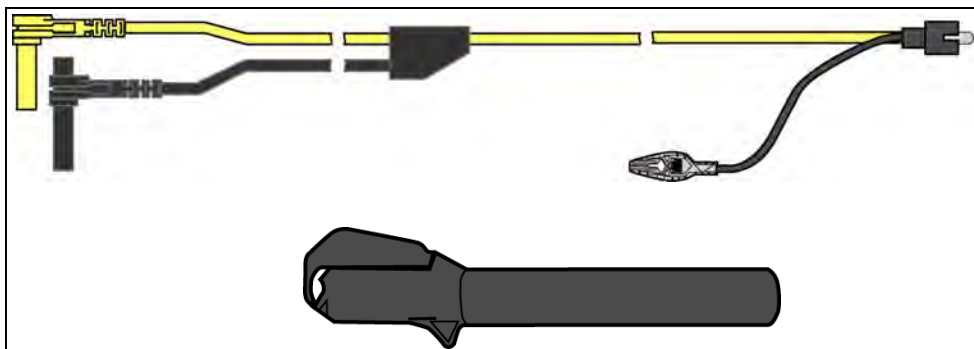

Figure 11-5 Secondary Ignition Coil Adapter Lead and Clip-on Wire Adapter

i NOTE

Contact your sales representative for additional information on OEM specific CIC and COP secondary ignition adapters.

11.4.5 Low Amp Current Probe (optional)

The Low Amp Current Probe is used measure AC or DC current up to 60A. This probe includes two scales (0 to 20A) and (0 to 60A) that can be used to provide accurate and reliable non-intrusive current measurement for components such as, ignition coils, fuel injectors, fuel pumps, relays, and electric motors.



Figure 11-6 Low Amp Current Probe

11.4.6 Temperature Probe Adapter (optional)

The temperature probe adapter can be used to measure temperatures ranging from -50°F to $1,800^{\circ}\text{F}$. Different probes are available for surface, fluid and air temperature measurements.



Figure 11-7

11.4.7 Pressure Transducers and Adapters (optional)

Different pressure transducers and adapters are available for measuring positive and negative gas and liquid pressures. Depending on the adapter, measurement capabilities range from 1 to 5000 psi and up to 29 inHg. Measurement and application capabilities vary per device.



Figure 11-8

11.4.8 Waveform Demonstration Tools (optional)

To help you sharpen your lab scope and graphing multimeter skills, optional waveform demonstration tools are available as a training aid. These demonstration tools generate common waveforms, and allow you to vary their display characteristics by turning glitches on/off, helping you to become more familiar with the lab scope controls. Common waveforms include, AC sine wave, variable frequency and pulse, secondary ignition, and more. There are two tools currently available, the standard model (Figure 11-9 left) and the vehicle simulator model (Figure 11-9 right) which produces waveforms (e.g. Crankshaft Position Sensor (CKP), Camshaft Position Sensor (CMP), Accelerator Pedal Sensor (APP), Wheel Speed Sensor (WSS) Signals, and more) representative of a 2012 BMW 328i Sedan.

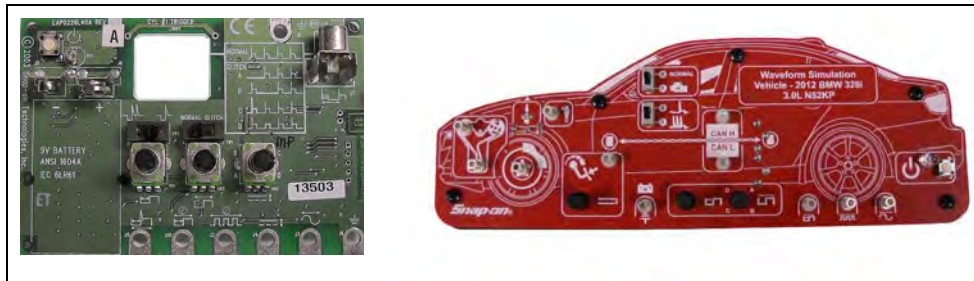

Figure 11-9

11.5 General Information

This section describes the general Scope Multimeter control icon functions, screen layout and optional settings. The screen layout and control icon functions are shared between the digital/graphing multimeters and lab scope.

NOTE

Scope and Multimeter tests are not vehicle specific, therefore vehicle identification is not required.

11.5.1 Scope Multimeter Screen Layout and Features

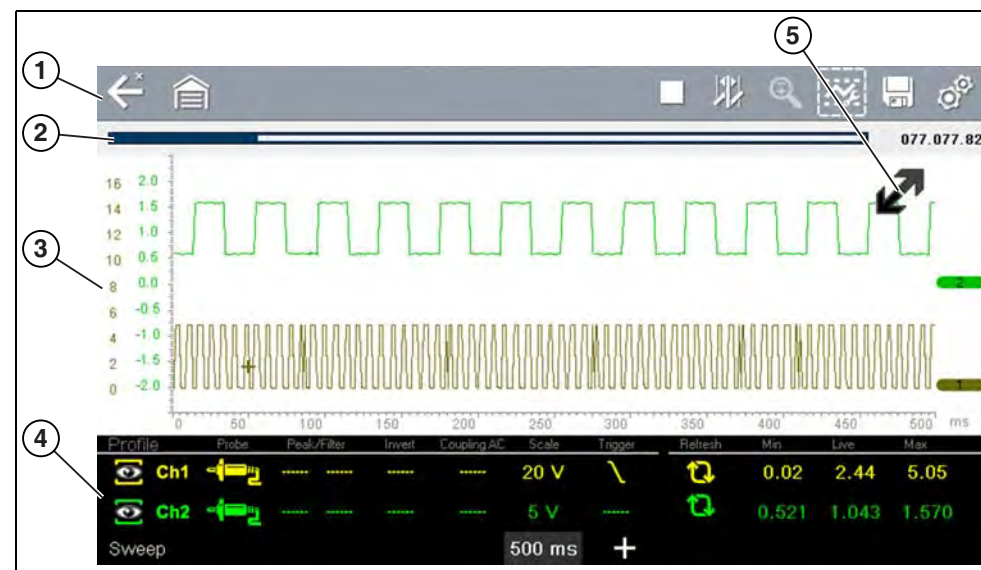

- 1— **Toolbar**—contains navigational and control icons
- 2— **Data Buffer Position Indicators**—graphical and numerical position indicators
- 3— **Main Body**—contains the meter/scope display
- 4— **Control Panel**—contains channel/trace controls
- 5— **Expand/Collapse icon**—toggles display between split and full screen views

Figure 11-10



Scope Multimeter Control Icons

The following control icons are common across most Scope Multimeter functions, however use may vary depending on the active function or test. A yellow frame surrounding an icon (highlighted), indicates it is selected. Other control icons (not shown) are described in [Common Toolbar Control Icons on page 8](#).

Icon	Function
	Pause - Pauses the data buffer
	Start (Capture) - Resumes active data collection.
	<p>Control Panel - (a). In full screen mode, when selected this icon becomes surrounded by a white frame and opens the control panel at the bottom of the screen while switching active selection focus to the Show/Hide or Probe icon in the Control Panel.</p> <p>(b). In split screen mode (control panel open), when selected this icon becomes surrounded by a white frame and switches active selection focus to the Show/Hide or Probe icon in the Control Panel.</p> <p>Note: Switching active selection focus to the Control Panel allows manual navigation (using the directional control buttons) of the Control Panel control icons</p>
	Zoom - Increases and decreases screen magnification. The zoom function is only available during data review (scope paused).
	Cursors - Toggles cursors on/off.
	<p>Step Forward - moves to the next point in the data. To quickly step forward, select this icon (yellow frame appears) then press and hold the Y/✓ button.</p> <p>(Note: To quickly step forward during data playback, press and hold the icon down until a red frame appears around the icon.)</p>
	Forward 1 Frame - allows forward movement by one frame. To quickly skip forward, select this icon (yellow frame appears around icon) then press and hold the Y/✓ button

Icon	Function
	<p>Step Back - moves to the previous point in the data. To quickly step backward, select this icon (yellow frame appears) then press and hold the Y/✓ button.</p> <p>(Note: To quickly step backward during data playback, press and hold the icon down until a red frame appears around the icon.)</p>
	Back 1 Frame - allows backward movement by one frame. To quickly skip backward, select this icon (yellow frame appears around icon) then press and hold the Y/✓ button.
	Expand / Collapse - Expands and collapses the Trace Detail area on the screen

Main Body

The main body may display the following:

- **Menu** - Select from a menu using the touch screen or the control buttons.
- **Meter/Scope Display** - Up to two signal traces can be displayed simultaneously. Each trace is displayed as voltage over time and the voltage level is recorded on the vertical, or “y”, axis and time is presented on the horizontal, or “x”, axis of the screen.

Data Buffer Position Indicators

The graphing multimeter and lab scope functions have the capability to save, store and playback, data (signals) utilizing internal storage “buffer” memory.

The Data Buffer Position Indicators are used to visually see the overall amount and position of the of stored buffer data during saving and playback.

For additional information on the Data Buffer, Data Buffer Position Indicator and Saving, Storing and Reviewing Data files, see [Saving Data Files on page 105](#).

11.6 Operation and Controls

This section describes the general operation and controls used to configure the scope or meter to perform testing. All three functions share similar control panel settings, see [Control Panel and Settings](#) on page 84 for additional information.

NOTE

The information in the following sections is intended as a guide and general overview of the controls and functions used within the Scope Multimeter. Not all the settings or controls described throughout this section are applicable with all functions.

▶ To open a scope multimeter function:

1. Select the **Scope Multimeter** icon from the home screen.
2. Select either **Lab Scope**, **Graphing Multimeter** or **Digital Multimeter** from the menu.

11.6.1 Test Lead / Probe Connection

Standard “safety type” test lead jacks are located on the top of the diagnostic tool, and are compatible with many test leads and probes ([Figure 11-11](#)). Insert the applicable test lead or probe terminal end into the jack to complete the connection.

IMPORTANT

To avoid damaging test leads, do not pull on the wire when removing the leads from their jacks. Pull only on the lead terminal end.

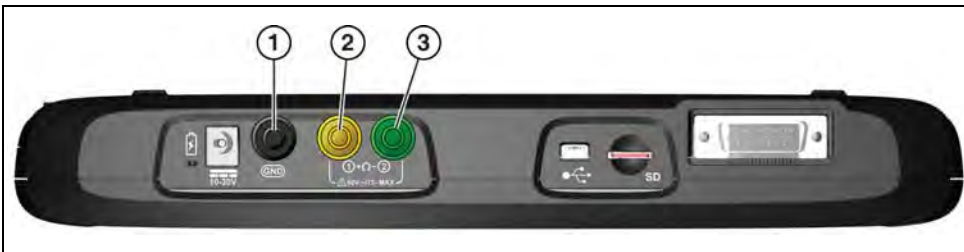

- 1— Ground Jack (Black)
- 2— Channel 1 Jack (Yellow)
- 3— Channel 2 Jack (Green)

Figure 11-11 Scope Multimeter Test Lead Jacks

11.6.2 Test Lead / Probe Calibration

Certain tests may display a confirmation prompt asking “Do you wish to calibrate this probe?” before continuing with the test. As general practice, it is important to ensure the test probe is calibrated before testing, to ensure accurate results.

Typical resistance, pressure, and vacuum tests will display the calibration message, reminding you to calibrate the probe. To perform the probe calibration, select **Yes** at the prompt and continue to follow the onscreen instructions to complete the calibration.

Example: For the ohms (resistance) calibration process, once completed, zero ohms should be displayed when the leads are connected together. When the leads are separated, the upward arrows on the display indicate infinite resistance or an open circuit.

NOTE

*During an ohms test or a pressure test, a manual probe recalibration can be initiated by selecting the probe icon from the Control Panel to open the probe menu. Then select either the **Ohms** or **Pressure (100, 500, 5000)** items from the probe menu. The menu selections will display a graphic of a balance scale with an “X” through it (on right side) to indicate that probe is not calibrated ([Figure 11-12](#)).*

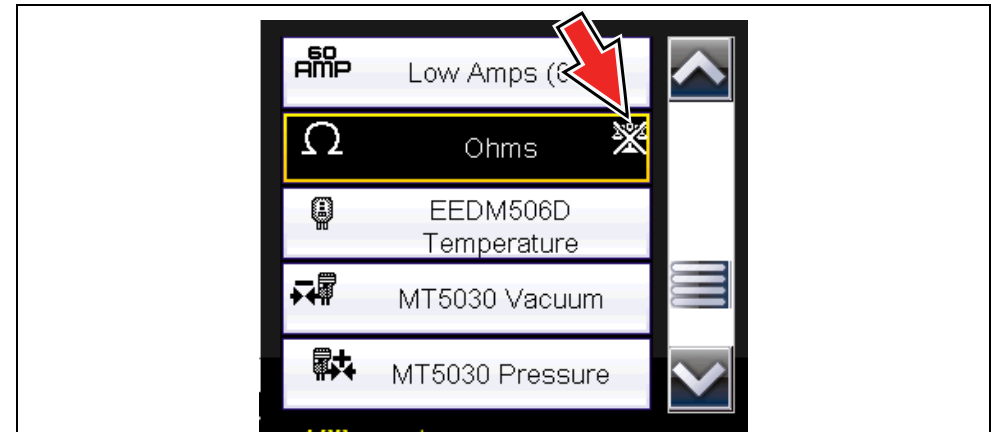

Figure 11-12 Probe menu - Ohms with “not calibrated” indicator displayed

11.6.3 Control Panel and Settings

The control panel is common to all three Scope Multimeter functions, and contains the channel (or “trace”) settings and controls that are used to monitor and adjust the signal being measured. This section provides a general overview of all the channel settings and control features used across all three Scope Multimeter functions.

NOTE

This section is intended as a general overview of the channel settings. Not all the settings or controls described in this section are applicable with all functions, some may be “grayed out” or not active (applicable) depending on the function or test. Function availability is noted as applicable.

NOTE

The control panel can be toggled on/off by selecting the Expand/Collapse Icon to switch the screen between full and split test meter views.

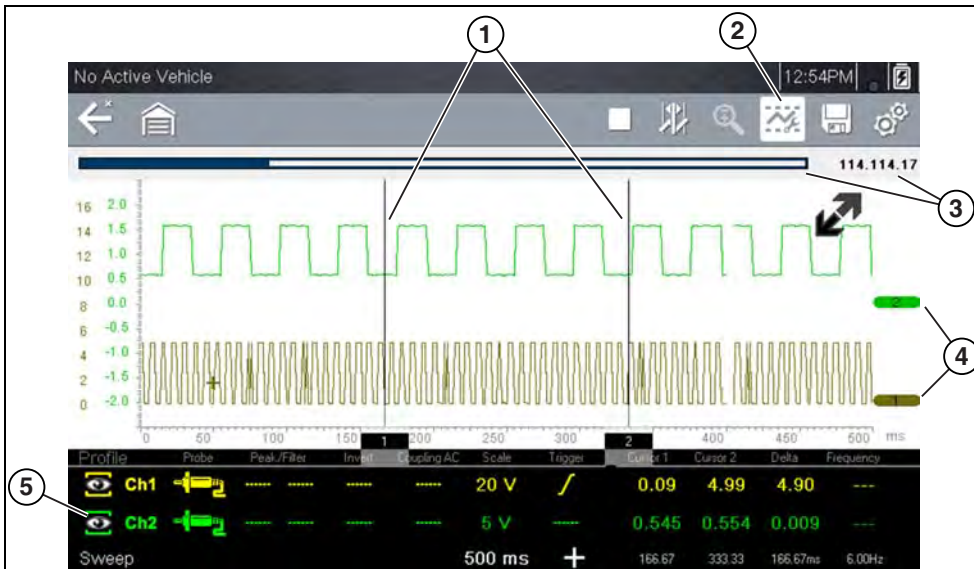

- 1— Cursors
- 2— Control Panel Icon
- 3— Data Buffer Position Indicators—graphical and numerical position indicators
- 4— Zero Base Line Indicators
- 5— Control Panel—contains channel/trace controls and settings

Figure 11-13

Scale, Sweep and Probe Settings

The most common and typically the first adjustments made when performing tests are the setup or adjustment of the scales and selection of a probe. All three of these adjustments are made from the control panel and are described in the following sections.

The following illustration is for reference, and identifies key terms and features used throughout the following sections:

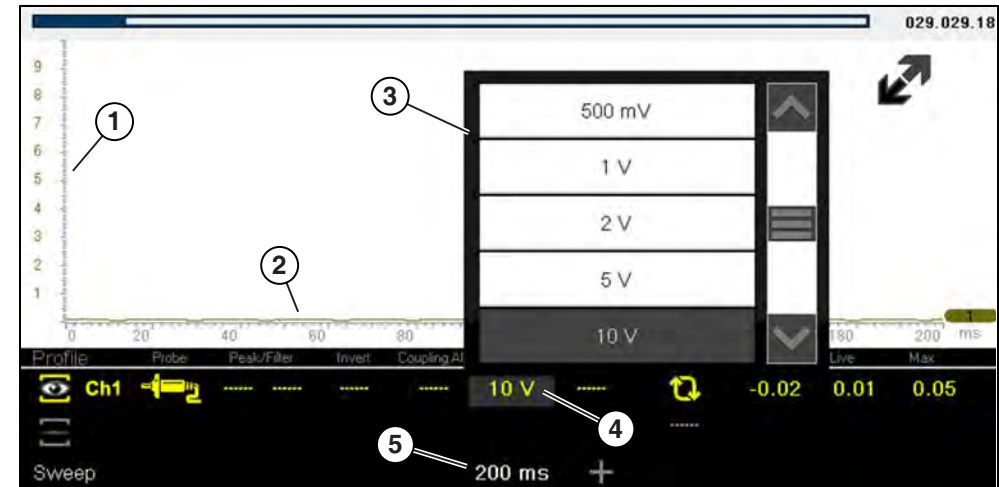

- 1— Vertical Scale - [Y axis]
- 2— Horizontal (sweep or time) Scale - [X axis]
- 3— Vertical Scale Menu
- 4— Vertical Scale Icon
- 5— Sweep Scale Icon

Figure 11-14



Scale (Vertical scale adjustment)

The vertical scale (Y-axis) represents what is being measured (voltage, amperage, pressure etc.), and the unit of measurement it is being measured in. The vertical scale is “always” divided into 10 major divisions; how these divisions are defined, sets the scale of measurement.

NOTE

Vertical scales (either channel) can be set independently.

NOTE

Optional vertical scale preference settings are available. The Divisions option allow you to change (to your preference) how the vertical scale menu selections are represented, and the type of value that displays in the vertical scale icon. See [Divisions](#) on page 98.

To adjust the vertical scale unit of measurement, select the **Vertical Scale** icon to open the vertical scale menu. Select a value then press the **N/X** button, to exit the menu. The value displayed in the vertical scale icon indicates the active value.

Example: Selecting 10V, changes the vertical scale to a 10V volt scale. The scale is “always” divided by 10, therefore each division is incremented by 1V.

Example: Selecting 50 psi displays a 50 psi scale that is divided by 10, therefore each division is incremented by 5 psi.

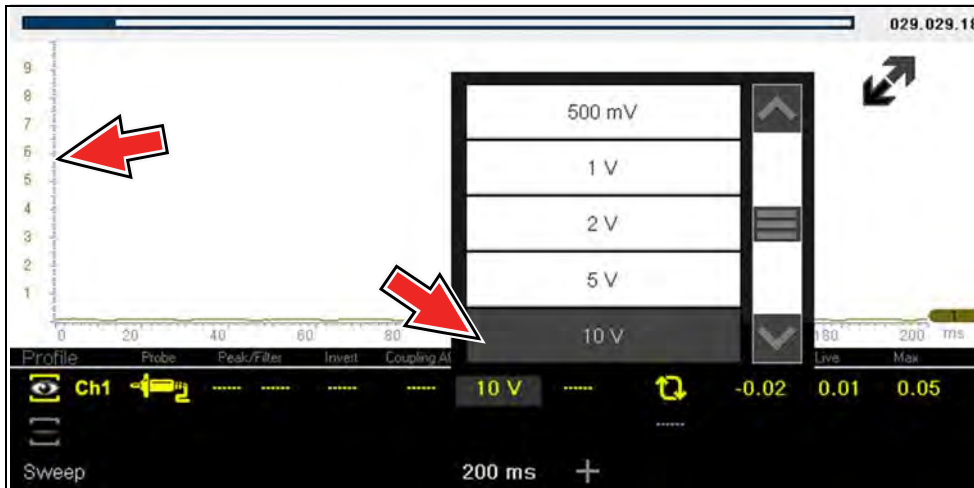

Figure 11-15

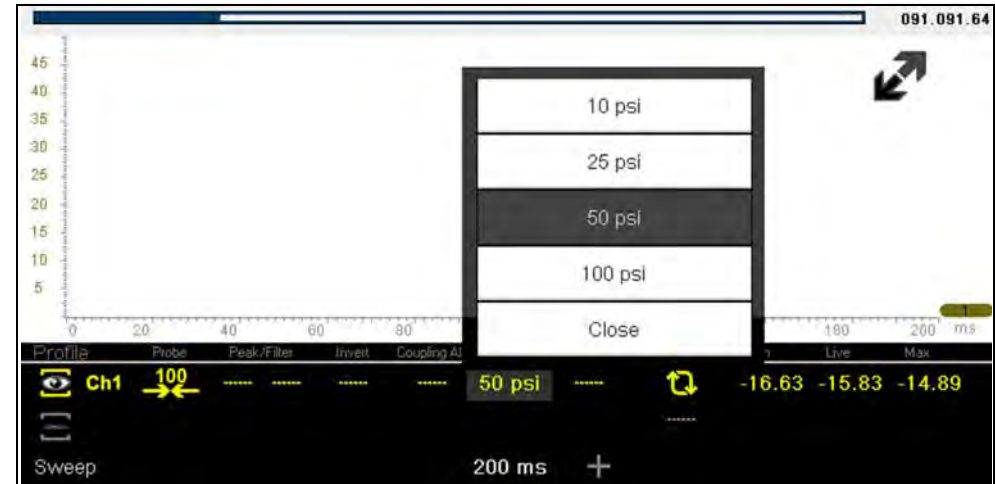

Figure 11-16



Sweep (Horizontal or Time scale adjustment)

The horizontal scale (X-axis) represents time, and the unit of measurement it is being measured in. The horizontal scale is “always” divided into 10 major divisions, how these divisions are defined, sets the scale of measurement. The value displayed in the sweep Scale icon indicates the active sweep setting.

NOTE

The sweep setting applies to all channels and cannot be set independently per channel.

To adjust the sweep scale unit of measurement value, select the Sweep Scale icon to open the sweep scale menu. Select a value then press the **N/X** button, to exit the menu.

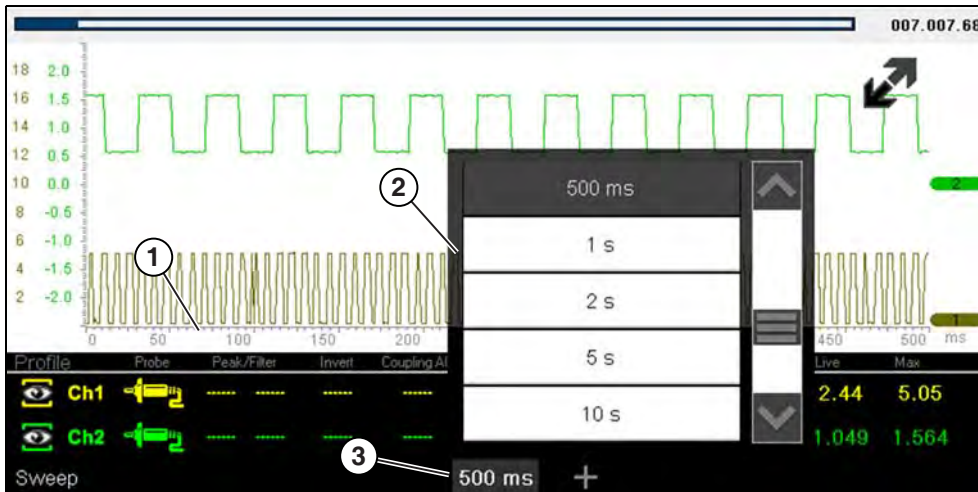

- 1— Sweep Scale
- 2— Sweep Scale Menu
- 3— Sweep Scale Icon

Figure 11-17

Example: Selecting 500ms, changes the sweep scale to a 500ms scale. The scale is “always” divided by 10, therefore each division is incremented by 50ms.



Figure 11-18



Probe (Probe type “test” selection)

Different types of Probes are available from the probe option menu, depending on which type of test you are performing. Changing the probe selection, also changes the vertical scale to the applicable type of measurement.

To select a Probe type, select the **Probe** icon to open the probe option menu, then select a probe. The probe icon will change to the selected probe. Select **Close** from the menu to close the menu.



Figure 11-19 Probe option menu

For probe calibration information, see [Test Lead / Probe Calibration](#) on page 83.

Probe “test” Options	
Menu Option	Probe / Device Used
Test Lead - Volts DC	Standard Channel 1 and 2 test leads with alligator clips or test probes
Vacuum 100	(optional) 0-100 psi pressure transducer with pressure adapter
Pressure 100	
Pressure 500	(optional) 0-500 psi pressure transducer with pressure adapter
Pressure 5000	(optional) 0-5000 psi pressure transducer with pressure adapter
Low Amps 20	(optional) Low Amp Probe
Low Amps 40	
Low Amps 60	
Ignition	(optional) Secondary ignition adapter lead with desired secondary ignition coil adapter
EEDM506D Temperature	(optional) Part number - EEDM506D temperature adapter
MT5030 Vacuum	(optional) Part number - EEDM5030 0-500 pressure adapter
MT5030 Pressure	

Channel Settings

The majority of the channel (trace) settings and controls are located in the Control Panel. Each setting is represented by an icon, or a value. Icons are used to make adjustments, and the displayed values represent an individual characteristic. Depending on the test, applicable settings are displayed. The following image shows different views of the control panels to identify the different controls.

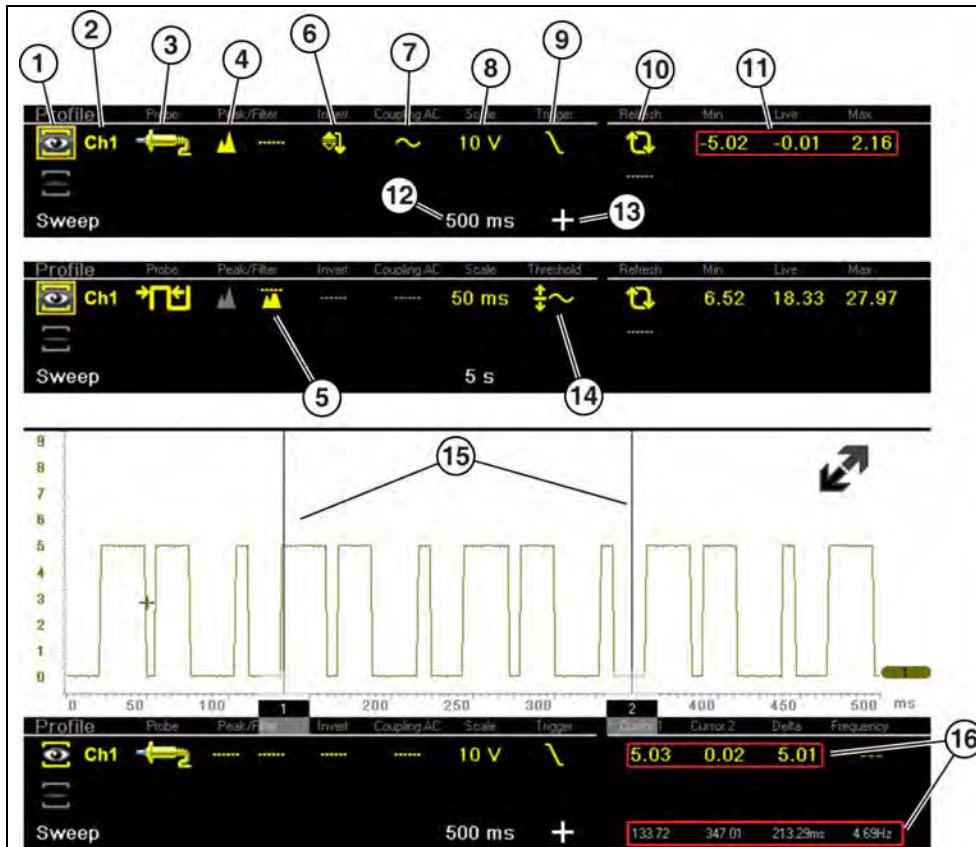

Figure 11-20 Probe option menu



- 1— **Show/Hide (Channel display on/off)**—turns channel on/off
- 2— **Trace (Zero Baseline position adjustment)**—adjusts zero baseline position
- 3— **Probe (Probe type “test” selection)**—changes test probe function
- 4— **Peak Detect**—maximizes sampling rate
- 5— **Filter**—removes signal noise or interference
- 6— **Invert**—switches signal polarity
- 7— **Coupling AC**—blocks the DC portion of signal
- 8— **Scale (Vertical scale adjustment)**—adjusts vertical scale
- 9— **Trigger**—turns triggering on/off, and sets direction of trigger slope
- 10— **Refresh**—clears Min, Max and Live values and resets to zero
- 11— **Min, Live and Max Display Panel**—displays lowest, highest and current trace measurements set since the test was activated
- 12— **Sweep (Horizontal or Time scale adjustment)**—adjusts horizontal scale
- 13— **Trigger Position Icon**—opens trigger position control panel
- 14— **Threshold**—turns auto threshold on, to provide a more accurate measurement on select tests where noise is present (GMM only)
- 15— **Cursors**—used to measure time, amplitude and frequency
- 16— **Cursor Measurements Panel**—displays signal amplitude at cursor and cursor position in time



Show/Hide (Channel display on/off)

The Show/Hide icons allow you to turn the channels on and off.

To turn a channel on and off, select the applicable channel's **Show/Hide** icon.

Show/Hide Icons	
On (Channel displayed)	Off (Channel not displayed)
	

Trace (Zero Baseline position adjustment)

The Trace icon identifies the channel number and is used to open the zero baseline adjustment controls.

To adjust the vertical position of the zero baseline (0 value) of a trace (for either channel), select the **Trace** icon or to open the zero baseline adjustment controls. Select the up/down arrows to make adjustments or press the up/down directional buttons. Tap the main body screen section or press the **N/X** button, to exit.

The zero baseline can also be repositioned by touching and dragging the baseline marker up/down on the screen.

Trace Icon

Peak Detect

Peak Detect Off

When peak detect is off, the scope samples at a high rate but saves just enough sample points to the data buffer memory to plot a waveform across the screen. No preference is given to any point during the selection process.

NOTES

— Turning peak detect “off” is suitable for basic measurements, and viewing waveforms (e.g. oxygen (O2) or Cam sensor) when capturing fast events is not necessary.

— The longer the time sweep, the greater the chance a glitch could be missed because it occurred in between the sample points saved to the data buffer memory. To increase the chance of capturing a glitch with peak detect “off”, a shorter time sweep should be selected.

— Turning peak detect “off” avoids the need for an external filter to decrease the display of unwanted noise, which can make diagnosis more difficult.

Example: With a time sweep of 10 seconds on a screen 100 points wide, the effective sample rate would be 10 times a second. Decreasing the time sweep to 1 second, increases the effective sample rate to 100 times a second. At this time setting, a fast occurring event is more likely to be captured due to the increased rate. This is the standard mode of operation for many scopes.



Peak Detect On

When peak detect is “on”, all sample points are evaluated. The points stored to the data buffer memory are intelligently selected to capture fast events that might be missed at slower effective sample rates. Peak Detect captures fast events, spikes and glitches for signals going in both positive and negative directions.



NOTES

— Turn peak detect “on” when capturing fast events (e.g. ignition firing voltage, glitches, and intermittent events).

— Turning peak detect “on” may capture unwanted noise, therefore, using peak detect may not be suitable for some tests (e.g. oxygen (O₂) sensor), as the waveform may be more difficult to evaluate due to the additional noise that may be displayed.

— Peak Detect decreases the possibility of waveform aliasing.

To turn peak detect on and off, select the **Peak Detect** icon.

Peak Detect Icons	
On (Sampling maximized)	Off (Sampling not maximized)
	

Filter

Using the filter feature can minimize or smooth out signal spikes and fast variations, depending on which function is its used with.

Filter - Lab Scope

Using the filter with the lab scope, smooths out fast spikes, which helps to provide a good balance between noise suppression and signal integrity.

Using the filter is useful when working with scales of 5 volts and below, as the lower the voltage scale, the more likely noise can occur.

Example: Using the filter is helpful when testing components such as, an O₂ sensor (1 or 2 volt scale), or when performing a throttle position (TP) sensor sweep test (5 volt scale).

In addition, the filter is also helpful for low amp probe tests, as a low voltage scale is used to measure the output of the probe (due to the conversion factors of the probe).



Example: For a probe with a conversion factor of 100 mV/A connected to a 2 amp load, the scope uses a 200 mV scale to measure the output of the probe. The scope converts the measured output to 2 amps for display on the screen.

Filter - GMM

Using the filter with the GMM, the filter minimizes noise by ignoring or smoothing out fast signal spikes.

- For a direct measurement test, such as volts, amps, or pressure, the filter minimizes the display of very fast spikes by averaging the sampled data when filter is active.
- For a calculated measurement test, such as frequency, pulse width, dwell, or duty cycle, extremely fast spikes (20 μS and faster) from sources like the ignition system are ignored when filter is active.

To turn the filter on and off, select the **Filter** icon.



Filter Icons	
On (Interference is suppressed)	Off (Interference is not suppressed)
	

Invert

The Invert feature is used to switch signal polarity, so the trace appears upside down (inverted) on the screen. This is typically used when measuring amperage using the low amp probe, or high-voltage signals like, secondary ignition.

Example: A signal that normally rises from 0 to +5 volts, if inverted would show falling from 0 to -5 volts.

To turn inversion on/off, select the **Invert** icon.

Invert Icons	
On (Polarity is inverted)	Off (Polarity is not inverted)
	





Coupling AC

Coupling AC subtracts the average value of a signal so that small variations can be displayed in the waveform. This is accomplished by blocking the direct current (DC) portions of a signal in order to amplify (show) the alternating current (AC) portions of the signal, without driving the trace off of the screen.

Using coupling AC can be helpful when testing and diagnosing alternator ripple or fuel pump amperage, by allowing you to see any abnormal small variations or events.

To turn coupling AC on and off, select the **Coupling AC** icon.

Coupling AC Icons	
On (DC signal portion blocked)	Off (DC signal portion not blocked)
	

Trigger

NOTE

The Trigger feature is only available in the lab scope function.

A trigger can be used to stabilize a changing or erratic signal (a signal that may flicker or drift as it refreshes), so that it is easier to view or diagnose. This stabilization effect is accomplished by basically displaying the same part of the trace repeatedly from the same starting point, thus the flicker or drift is minimized which makes the trace appear more consistent or static.

A trigger is basically a “specific point” on the display, at which a trace will start to display (start the sweep) if it crosses that point.

The trigger feature allows you to set the conditions of that “specific point” also called a “trigger point”. When the trigger conditions are set, and a trace “meets” those conditions (crosses the trigger point), the trace will start.

Trigger conditions:

- Vertical scale position (amplitude)
- Sweep position - the horizontal scale position, or position in time
- **Slope direction** - the direction the trace must be moving (up/rising or positive) or (down/falling or negative) when crossing the trigger point.

NOTES

Triggers can be set on any channel, however only one trigger can be activated (used) at a time.

If a trigger is set outside the range of the scales, a yellow marker (e.g. arrow with plus symbol) will be displayed (Figure 11-22) indicating the trigger is out of range and a confirmation screen will display.



When a trigger is set on a channel, and more than one channel is active (displayed), trigger conditions must be met for that channel in order to display all the other channels.



To turn a trigger on/off:

A trigger is activated by selecting the trigger icon from the control panel, which then automatically initiates trigger slope setup.

1. Select the desired channel's **Trigger** icon.
Each tap of the icon sets the trigger to a different slope setting, or turns the trigger off.
2. Select the desired slope setting, to turn the trigger on.

Trigger Icon	Description
	Rising (up or positive) - Trigger is turned on to start the trace on the rising edge (as signal begins to rise)
	Falling (down or negative) - Trigger is turned on to start the trace on the falling edge (as signal begins to fall)
	Off - Trigger is turned off.

3. Proceed to **“To set trigger position”** next to complete the trigger set up.



To set trigger position:

Trigger position (also called trigger level) can be adjusted in two ways:

- Dragging the trigger marker (*Figure 11-21*) on the touch screen - rough adjustment
- Using the trigger position control panel (*Figure 11-21*) - fine adjustment

The trigger marker is indicated by a plus symbol (+) on the display (*Figure 11-22*). The trigger marker represents the trigger point and is displayed on the screen when the trigger is turned on.

To roughly position the trigger marker, select and drag it into position using the touch screen.

4. To more accurately position the trigger marker, select the **Trigger Position Control** icon (*Figure 11-22*).

The trigger position control panel opens.

5. Use the directional controls provided, or the thumbpad directional controls to move the trigger marker into position (*Figure 11-21*). Sweep and vertical scale values are provided in the trigger position control panel, which gives you the precise position of the trigger marker.
6. Press the **N/X** button, to exit.

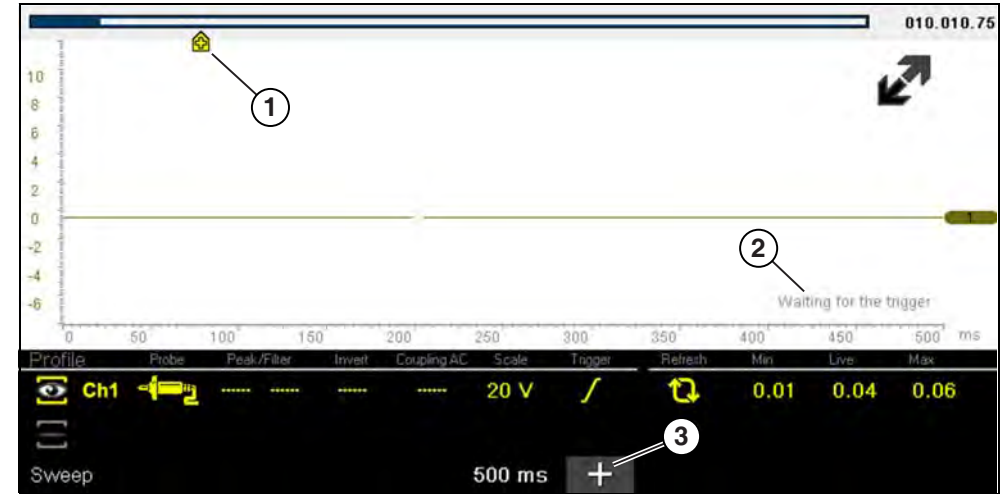

- 1— Trigger Marker (out of range symbol)
- 2— Waiting for Trigger Message
- 3— Trigger Position Control Icon

Figure 11-22



- 1— Trigger Marker
- 2— Trigger Position Control Panel

Figure 11-21 Trigger marker and position controls



Trigger Auto/Manual Mode (Optional Setting)

NOTE

The Auto and Manual Trigger modes allow you to set the criteria used to display signals on the screen. To change the trigger mode, the trigger must be set on one of the channels.

In both Auto and Manual Trigger mode the screen is updated when the signal crosses the trigger point in the selected direction (rising or falling), however:

- **Auto Trigger**—(default mode)
 - when Auto Trigger is on, even if the signal does not cross the trigger point, the screen automatically updates after a short period (allowing you to see the waveform). When this occurs, the message "Waiting for the trigger" (Figure 11-22) is displayed on the screen. The trigger point can then be set to optimize viewing.
- **Manual Trigger**
 - when Manual Trigger is on, if the signal does not cross the trigger point the screen will not update. This allows you to capture intermittent events, as the screen only updates when the signal meets your trigger selection.

NOTE

When using Manual Trigger, it may be easier to initially set the trigger point using Auto Trigger, as the screen will update regardless if the signal crosses the trigger point. Once the trigger point is set, then switch to Manual Trigger mode.



Selecting Trigger Auto/Manual Mode:

1. From the Control Panel (on the test meter screen), turn the trigger on for the desired channel.
2. Select the **Settings** icon from the toolbar.
3. Select **Settings > Configure Scope / Meter > Trigger Mode** from the menu selections.
4. Select either **Auto Trigger** or **Manual Trigger**.
5. Select **Back** or press the **N/X** button to navigate back to the test meter screen.

Threshold

NOTE

The Threshold function is only available in the Graphing Meter function for specific tests. This function may also be referred to as Auto Threshold Select (ATS).

The Threshold function can be used, to display and obtain a more accurate measurement when measuring signals (e.g. Frequency, Duty Cycle, MC Dwell and Pulse Width) that may be difficult to display or have noise or other undesirable variations in the signal. When selected, the Threshold function automatically sets a trigger and determines a threshold level in the middle of the signal range (calculated from the Min and Max measurements) to be used as a reference point to calculate the measurement. The falling edge (slope) of the signal is used in determining the threshold level.

To activate the Threshold function, select the **Threshold** icon, then select **Continue** from the confirmation screen (Figure 11-23). Once selected, the Threshold function remains active until the test is exited.

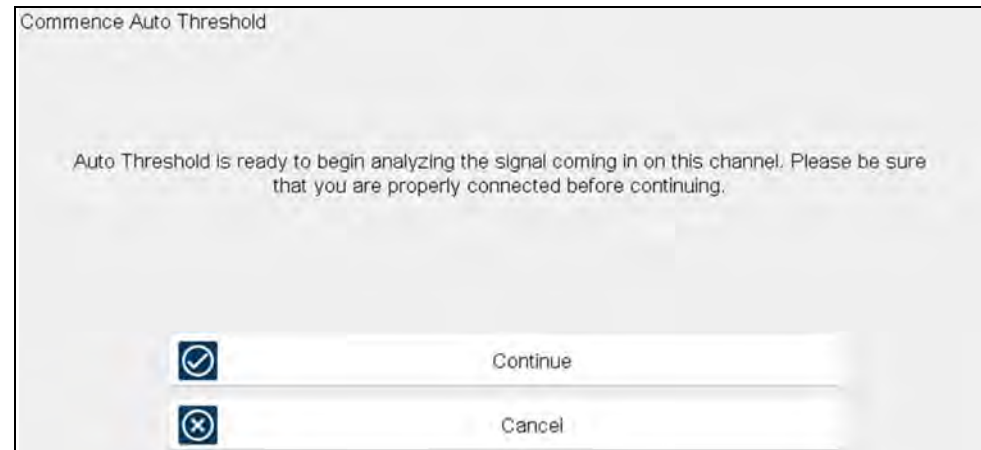

Figure 11-23 Auto Threshold Confirmation Screen

If after enabling the Threshold function, if the signal is still not displayed, reduce the vertical scale setting. Sometimes a low frequency signal may not display if the vertical scale is set too high. If the signal still seems incorrect use the lab scope to verify the signal integrity and signal spacing. Slow or unequal spacing will display as a band or ragged signal, depending on the sweep setting.



Refresh

Selecting the **Refresh** icon ([Figure 11-24](#)) clears the active trace(s) displayed and restarts the signal tracking from zero. It also clears the minimum, maximum and live measurements displayed for both channels.

Use the Refresh feature to:

- Track the variation in a component or circuit under a certain condition. If the condition changes, Refresh lets you start tracking again to see the change.
- Verify that a connection problem you found by looking for a dropout or spike in min/max values has been fixed.

Min, Live and Max Display Panel

When Cursors are turned off, the Min, Live and Max display panel ([Figure 11-24](#)) is turned on displaying each channel's active signal minimum and maximum recorded measurements and live measurement.

- **Min** - lowest measurement recorded for the signal since the test was activated, or from the last time Refresh was selected
- **Max** - highest measurement recorded for the signal since the test was activated, or from the last time Refresh was selected
- **Live** - represents the "live" running average measurement of the signal being measured

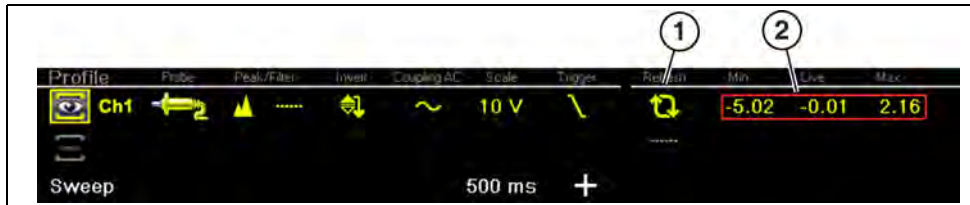

1— Refresh Icon

2— Min, Live, Max Display Panel

Figure 11-24

Cursors

NOTE

The Cursors feature is only available in the lab scope and Graphing Meter functions.

Two vertical cursors are provided that allow you to make precise signal measurements, when determining signal characteristics such as, amplitude at specific points, and cycle time (duration) or frequency.

Using cursors can also be helpful when performing certain diagnostic tests, such as:

- O2 sensor rich/lean switch time
- fuel injector pulse width frequency
- secondary ignition spark duration
- crankshaft position sensor frequency

Measurements can quickly be taken between the two cursors, when measuring a single cycle or across multiple cycles by positioning the cursors at the start and end of the cycle or multiple cycles.

The cursor measurements panel is displayed when using the cursors, providing you digital values of the cursor measurements. See [Cursor Measurements Panel](#) on page 95 for additional information on the values displayed in the cursor measurements panel.



To turn the cursors on/off:

1. To turn the Cursors on (display), select the **Cursor** icon from the toolbar. Two cursors are displayed on the test screen, and the Refresh, Min, Live, Max display panel is switched off and replaced by the cursor measurements panel. See [Cursor Measurements Panel](#) on page 95 for additional information on the cursor measurements panel.

To turn the Cursors off, select the **Cursor** icon again from the toolbar.

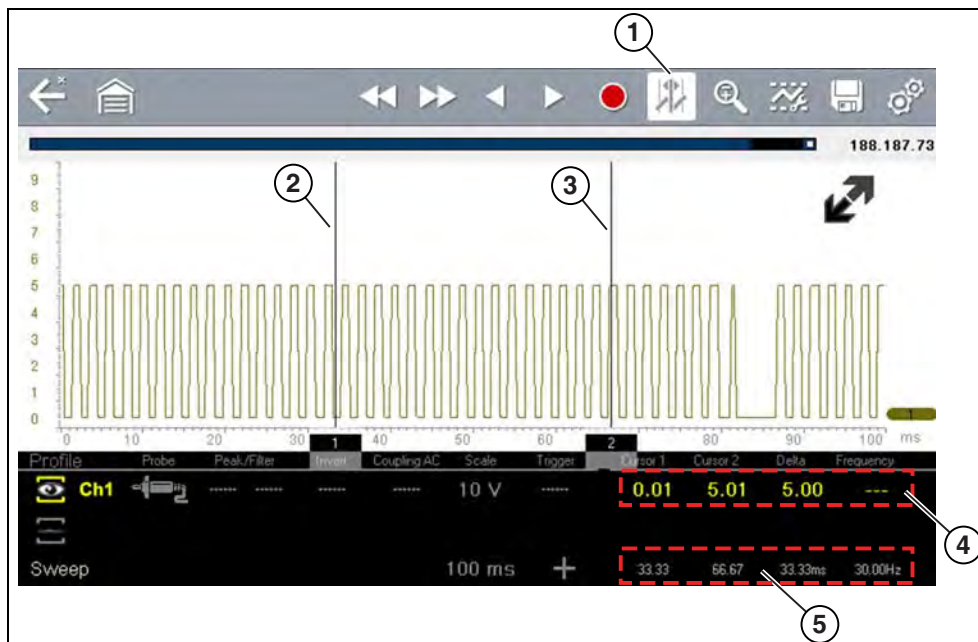

- 1— Cursors Icon
- 2— Cursor (no. 1)
- 3— Cursor Marker (no. 2)
- 4— Cursor Measurement Panel - amplitude and delta display
- 5— Cursor Measurement Panel - time and delta display

Figure 11-25



To position the cursors:

The cursors can be positioned anywhere within the range of the sweep scale ([Figure 11-25](#)).

1. Turn the Cursors on.
2. Using the touch screen, select either cursor marker (base) and drag it to the desired position.

Cursor Measurements Panel

When the cursors are turned on, the Refresh, Min, Live, Max display panel is switched off and replaced by the Cursor Measurements Panel.

The cursor measurements panel displays the following signal and cursor measurements:

- Signal amplitude at two points
- Signal amplitude difference (delta) between two points
- Cursor position in time at two points
- Difference (delta) in time between the cursors
- Frequency - frequency of the signal for the time period between cursor 1 and 2

The cursor measurements panel contains values for each channel in two displays.

The amplitude and delta display is provided in the channel specific color and includes:

- **Cursor 1** - signal amplitude at cursor 1 position
- **Cursor 2** - signal amplitude at cursor 2 position
- **Delta** - signal amplitude difference between cursor 1 and 2

The time and delta display is gray in color and includes:

- **Cursor 1** - cursor position in time at cursor 1
- **Cursor 2** - cursor position in time at cursor 2
- **Delta** - difference in time between cursor 1 and 2
- **Frequency** - the frequency value (Hz) of the signal for the time period between cursor 1 and 2

**NOTE**

Frequency is the number of times a signal repeats itself per second and is measured in hertz (Hz).

The frequency value displayed, is the inverse of the Delta value, and can also be calculated as 1 divided by Delta. The frequency value (Hz) shown is automatically calculated by the scope.

Example 1: Delta = 20.46ms, to get frequency divide 1 by .02046 (1/.02046 = 48.87Hz)

Example 2: Delta = 2.53ms, to get frequency divide 1 by .00253 (1/.00253 = 395.27Hz)

Use applicable decimal point placement during division as the Delta value changes.

11.6.4 Secondary Ignition Testing

The lab scope function can be used to display secondary ignition waveforms for conventional and select CIC and COP systems. To display secondary ignition waveforms, optional secondary ignition coil adapter(s) and a coil adapter lead assembly are required.

Contact your sales representative to purchase the optional adapter leads and/or Secondary Ignition Clip-on or COP/CIC Adapters.

- Adapter lead assembly needed:
 - Secondary Coil Adapter Lead Assembly - connects the diagnostic tool to a secondary ignition adapter (yellow and black scope connectors and black RCA type adapter connector). See [Secondary Ignition Coil Adapter Lead and Clip-on Adapter \(optional\)](#) on page 80.

- Secondary Ignition Adapters available:

Different secondary ignition coil adapters are available as optional equipment. These adapters attach to either the secondary lead (spark plug lead) or directly to the secondary ignition coil in order to pick up the secondary ignition signal.

 - Universal kV Ignition Clip-on adapter - clips over a spark plug or coil lead. See [Secondary Ignition Coil Adapter Lead and Clip-on Adapter \(optional\)](#) on page 80.
 - Universal stick and flag type adapters - are loosely positioned next to or on a secondary ignition coil.
 - General purpose single flag pick-up.
 - General purpose stick pick-up.
 - Vehicle specific Clip-on adapters - are directly attached to (or next to) a secondary ignition coil (COP type) or to a distributor cap (CIC type). Secondary ignition coil-on-plug (COP) and coil-in-cap (CIC) adapters are available for universal and engine specific applications. All the adapters listed are available individually.
 - OEM specific COP adapters:
 - Ford (COP-1)
 - Chrysler (COP-2)
 - VW/Audi (COP-3)
 - Acura/Honda/Isuzu (COP-4)
 - Volvo/BMW (COP-5)
 - Mercedes-Benz (COP-6)
 - Mercedes-Benz Dual Type (COP-7)
 - BMW (COP-8)
 - Lexus (COP-9)
 - Chrysler/Jeep/Lexus/Toyota (COP-11)
 - OEM specific CIC adapters:
 - GM HEI (CIC-1)
 - Toyota/Honda (CIC-2)



Connecting the Secondary Coil Adapter Leads:

1. Connect the black (ground) lead into the diagnostic tool test lead ground jack.
2. Connect the yellow lead into the diagnostic tool test lead channel 1 jack.
3. Connect the adapter lead ground clamp to vehicle ground. If a jumper wire is used to extend the length of the adapter lead ground clamp lead, keep it as short as possible.
4. Connect the adapter lead RCA plug into the secondary ignition "clip-on" or COP/CIC coil adapter as needed.
5. Clamp the secondary clip-on adapter over a spark plug or coil lead, or attach the applicable COP/CIC coil adapter to the vehicle ignition coil.
6. Isolate the leads from other components, to avoid any unwanted noise that could be induced onto the signal.
7. From the lab scope function, select the Ignition Probe (probe setting).
8. If needed, turn the Invert function on.

Once a signal is displayed, further channel settings may be required to display the pattern characteristics you are looking for.

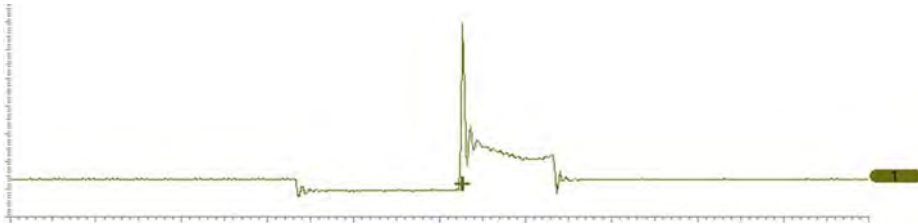

Figure 11-26 Typical Secondary Ignition Signal

11.7 Optional Settings

The following optional Scope/Meter settings are available, and can be set to your preference:

- [Trigger Auto/Manual Mode \(Optional Setting\)](#) on page 93
- [Display \(Grid on/off\)](#) on page 97
- [Divisions](#) on page 98

All optional settings are available from the Tools icon located on the Home screen. Select **Tools > Settings > Configure Scope/Meter** to access the options menu.

11.7.1 Display (Grid on/off)

The Display option allows you to turn the screen grid on/off.

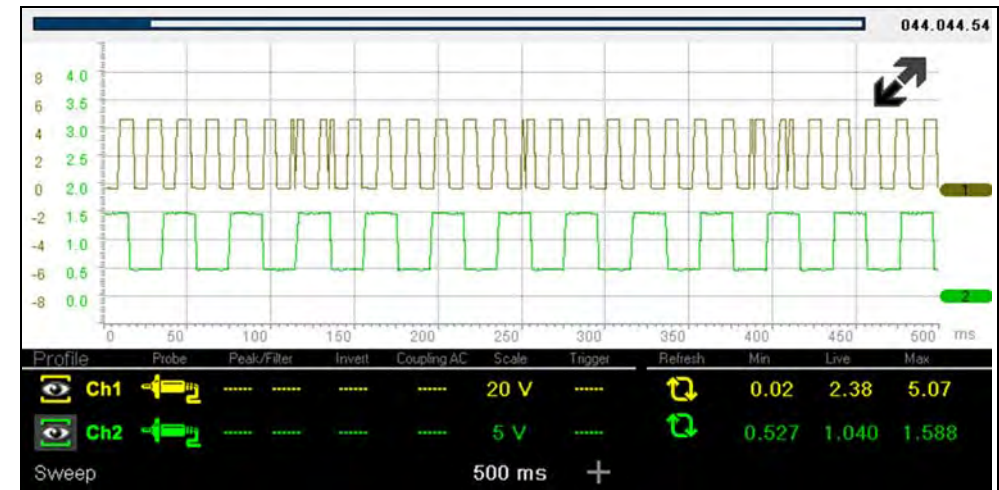

Figure 11-27 Grid on



Changing the Display (grid on/off):

1. Select the **Tools** icon from the Home screen.
2. Select **Settings > Configure Scope/Meter > Display** from the menu options.
3. Select the desired option:
 - **Show Grid**—turns grid lines on
 - **Hide Grid**—turns grid lines off
4. Select the **Back** icon or press the **N/X** button to return to the Settings menu.

11.7.2 Divisions

The Divisions options allow you to change (to your preference) how the Vertical Scale Menu selections are represented, and the type of value that displays in the Vertical Scale icon.

This section describes the following settings:

- **Trace**
 - Trace Full Scale
 - Trace Per Division
- **Display**
 - Display Full Scale
 - Display Per Division

The following illustration is for reference, and identifies key terms and features used in this manual.

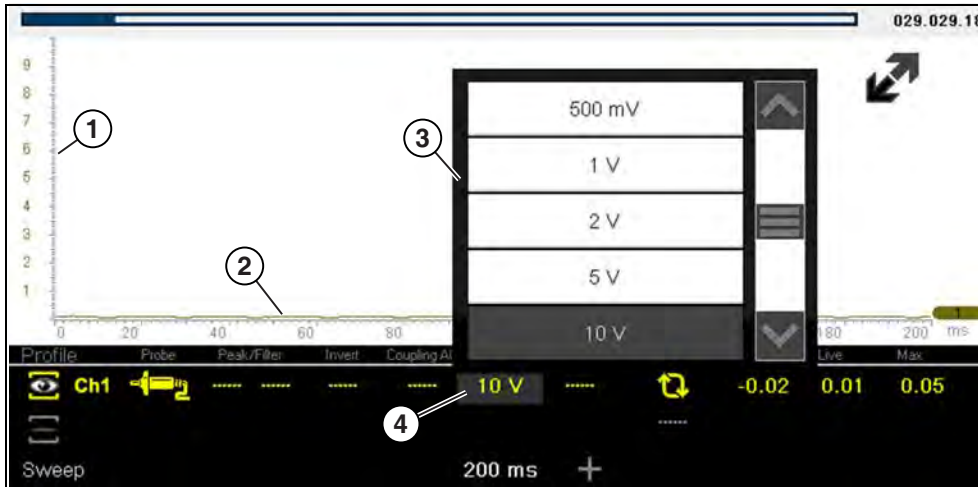

- 1— Vertical Scale
- 2— Sweep (horizontal or time) Scale
- 3— Vertical Scale Menu
- 4— Vertical Scale Icon

Figure 11-28

▶ To access the divisions option menu:

1. Select **Tools** from the Home screen.
2. Select **Settings** from the Tools and Setup menu.
3. Select **Configure Scope/Meter** from the Settings menu.
4. Select **Divisions** from the menu.
5. Select either option:
 - **Trace Settings** - see [Trace Settings on page 98](#)
 - **Display Settings** - see [Display Settings on page 100](#)
6. Select the **Back** icon or press the **N/X** button to return to the Settings menu.

Trace Settings

The Trace Settings option allows you to change how the vertical scale menu selections are represented.

NOTE

This setting ONLY changes the vertical scale, the sweep (horizontal) scale is NOT changed.

NOTE

When adjusting the vertical scale setting, it is important to remember that the vertical scale is divided into 10 major divisions, and all scale adjustments reflect this factor of 10. The division set of 10 cannot be changed, divisions cannot be added or removed.

Trace Full Scale - changes the dropdown vertical scale menu selections to full scale mode, which represents the selected unit of measurement over the entire (full) scale.

Example (Figure 11-29): Selecting 10V, changes the vertical scale to a 10V volt scale. The vertical scale is “always” divided by 10, therefore each division is incremented by 1V.

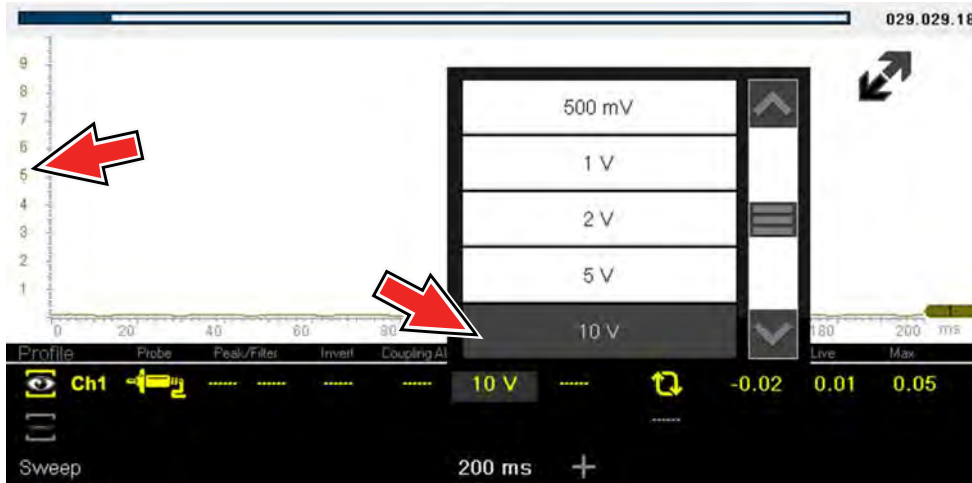

Figure 11-29

Trace Per Division - changes the dropdown vertical scale menu selections to ##/div mode, which in turn changes the vertical scale to represent ## by division.

- represents (variable) what is being measured (voltage, amperage, pressure etc.)

Example (Figure 11-30): Selecting 1.0V/div, displays a vertical scale divided by 10. The vertical scale is “always” divided by 10, therefore each division is incremented by 1.0V, thus a 10V scale.

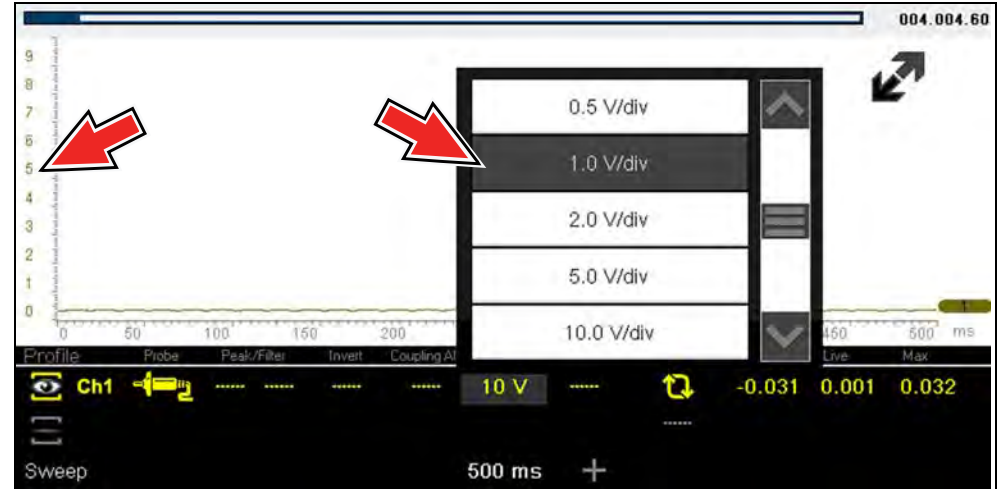

Figure 11-30

Display Settings

The Display setting allows you to change the displayed value in the Vertical Scale icon to your preference.

NOTE

This setting *ONLY* changes the value displayed in the Vertical Scale icon.

Display Full Scale - displays the value of the entire (full) scale

Example (Figure 11-31): If the vertical scale is set to 1V, the value displayed is 1V.

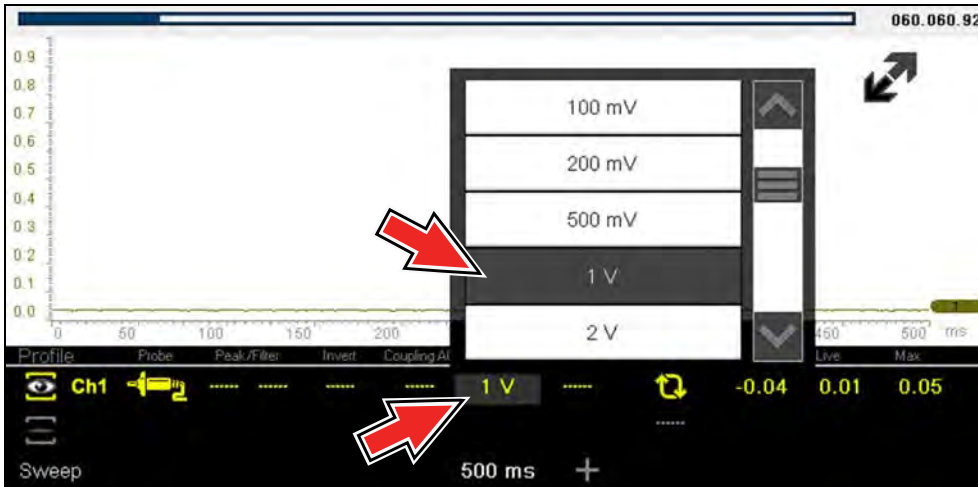

Figure 11-31

Display Per Division - displays the graduation value of the major scale divisions

Example (Figure 11-32): If the vertical scale is set to 1V, the value displayed is 0.1V.

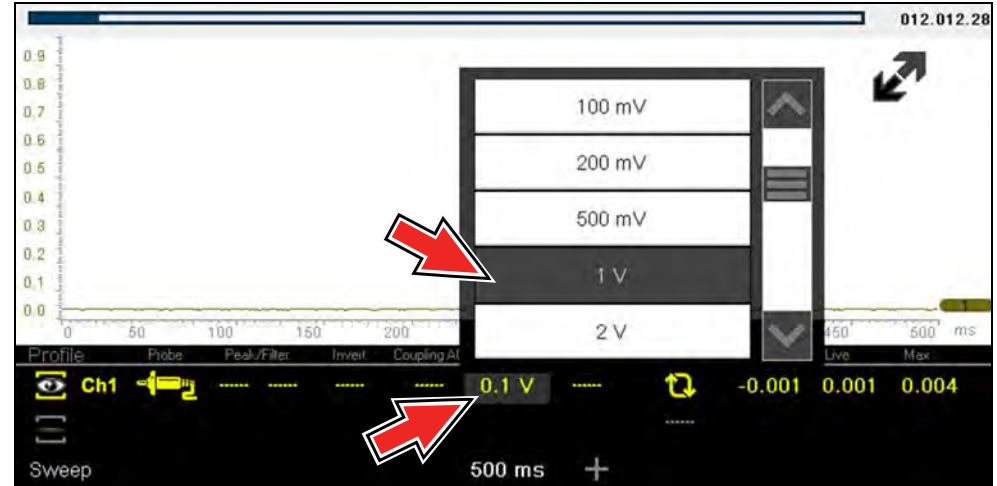

Figure 11-32

11.8 Capturing Data

The primary purpose and advantage of the Lab Scope and Graphing Multimeter, is their ability to capture, store and playback data (test signals). Having this ability can be invaluable when diagnosing intermittent issues, by providing you the ability to navigate through the data in detail to find events of interest, such as glitches and signal losses. The following sections describe the basics of the data buffer and the two basic modes of operation, Capture Mode and Review Mode.

11.8.1 About the Data Buffer

To gain a better understanding of the capabilities of the scope and the basics of capturing and reviewing data, understanding what the data buffer is and how it works is important.

The Lab Scope and Graphing Multimeter have the capability to capture, store and playback data (test signals) utilizing internal buffer storage memory. When a test function is selected (e.g. Lab Scope > DC Volts), the data is automatically stored in buffer memory, until the Pause icon is selected.

The amount of data you can capture is limited to a predetermined “total buffer memory” size. When the buffer memory reaches its full capacity, the data buffer will continue to store new data, however earlier stored data will be removed to allow room for the new data being stored. The most recent data is always available for review when the scope is paused, and can be reviewed using the toolbar controls

As a visual aid, a graphic Data Buffer Slider ([Figure 11-33 \(1\)](#)) is located at the top of screen and indicates the position of the current displayed frame of data in relation to the entire buffer memory capacity. **Note:** In Review Mode, the slider can be used to quickly move through paused data.

In addition, a Data Buffer Position Counter ([Figure 11-33 \(2\)](#)) displays the numerical position of the Data Buffer Slider within buffer memory.

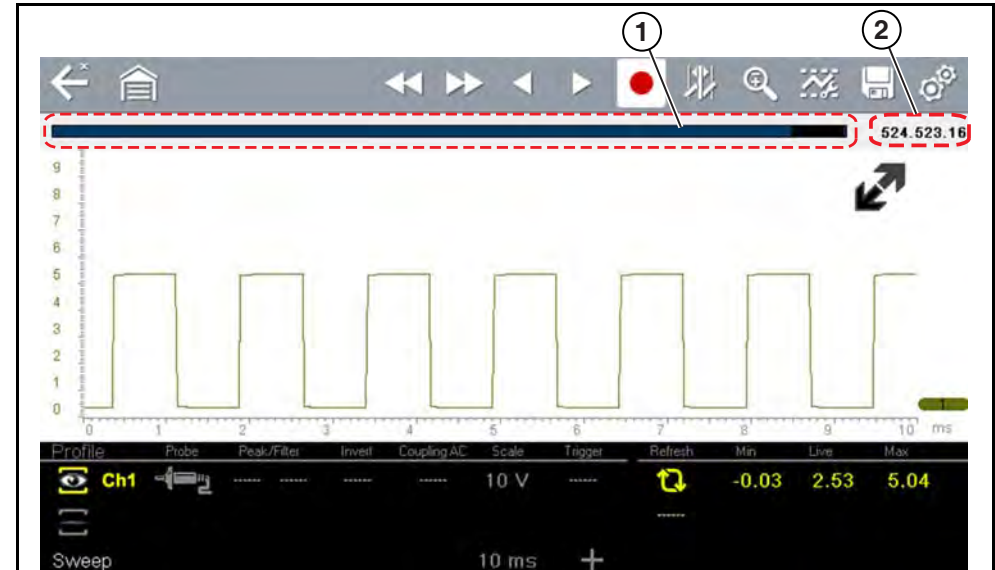

1— Data Buffer Slider

2— Data Buffer Position Counter (XXX (Total memory “frames” available):
XXX (Whole frame number): XX (Fractional frame number)

Figure 11-33

11.8.2 Capturing Data (Capture Mode)

For control icon descriptions, see [Scope Multimeter Control Icons](#) on page 82.

Whenever you open Lab Scope or the Graphing Multimeter, the device is in Capture Mode. In Capture Mode, data is continuously being captured and stored in buffer memory at the same time it is being displayed onscreen.

i NOTE

Data is continuously stored in buffer memory with or without an active input test signal or trigger.

To help you understand how to work with captured data, an important concept to remember is that data is captured over a period of time. Therefore there is a direct relationship between the length of time the data is captured in, and the resultant level of detail you will have when reviewing it.

As every testing situation is different, the following is provided only as a guide when capturing data to provide the best flexibility when reviewing the data to find events.

In most situations if you start by using a sweep setting that is best suited for viewing the waveform “live”, or at a setting that provides the best detail to the naked eye, this will allow you to either see the event you are looking for “live”, or allow you to use the zoom feature (in Review Mode) to zoom out (2, 8, 32X etc.) and then search through the data buffer for events of interest.

It is important to remember that whatever sweep setting you use during data capture is what the 1X zoom level will be when you switch to Review Mode. Therefore, if you capture data using a sweep setting where the pattern displayed is tightly compacted (can’t visually see detail), then when you try to use zoom you will not be able to see any detail, as you will only be able to zoom out from the setting where you originally captured the data (displaying an even greater level of compacted data).

In other situations you may need to start at a faster sweep (shorter time) to capture more detail “live”, then zoom out (in Review Mode) to get a wider view and then zoom in at the points of interest where you need more detail. Using this strategy you will capture less total time, but be able to see more detail.

For some situations, if the sweep setting you are using is not fast enough to capture the event your looking for, turning Peak Detect on will increase the sample rate and may allow you to see the event.

Using peak detect can also help in avoiding aliasing if the sweep time is too great for the waveform being captured. Using peak detect is not appropriate for every instance, but when using longer sweep settings, it can help increase the capture time by allowing you to capture more than you could without it and still capture dropouts and points of interest. See [Peak Detect](#) on page 89 for more information.

For additional information on setup and capturing data (input signals) see [General Reference](#) on page 106.

NOTE

Glitches may cause drivability problems and may not turn on the MIL or set DTCs. As a general guide when looking for a suspected signal glitch, always try to verify the problem by duplicating the conditions while capturing data. Utilize the GMM to monitor the signal over longer time periods and review the histogram for possible faults.

11.8.3 Pausing Data

Data continuously stores in buffer memory until the **Pause** icon is selected.

Selecting the **Pause** icon ([Figure 11-34](#)), allows you to temporarily pause the data (input test signal) to review it in detail. See [Reviewing Data and Using Zoom \(Review Mode\)](#) on page 102 for more information.

To resume data capture, select the **Start** icon.

For control icon descriptions, see [Scope Multimeter Control Icons](#) on page 82.

11.8.4 Reviewing Data and Using Zoom (Review Mode)

Review Mode allows you to search through the captured data in detail to find events of interest, such as glitches and signal losses.

Press the **Pause** icon ([Figure 11-34](#)) to open Review Mode.



Figure 11-34

To search through the captured data, select the desired control icon to move forward or backward through the data ([Figure 11-35](#)).

NOTE

You can also use the data buffer slider to quickly scroll through the captured data in buffer memory.

For control icon descriptions, also see [Scope Multimeter Control Icons](#) on page 82.



- 1— Back 1 Frame** Moves to the previous frame in the data
- 2— Forward 1 Frame** Moves to the next frame in the data
- 3— Step Back** Moves to the previous point in the data
- 4— Step Forward** Moves to the next point in the data
- 5— Start (Capture)** Resumes data capture
- 6— Data Buffer Slider**

Figure 11-35

NOTE

As there is a direct relationship between the length of time the data is captured in, and the resultant level of detail you will have when reviewing it, review the information in [Saving Data Files](#) on page 105 for tips on capturing and reviewing data.

Using Zoom

For control icon descriptions, see [Scope Multimeter Control Icons](#) on page 82.

The zoom function is only available in Review Mode, and can be an invaluable tool when searching for events of interest within captured data. Zoom effectively gives you the ability to change the magnification level of the signal sweep during data review.

As zoom, allows you to change the magnification level of the signal sweep, this allows you to compress or expand multiple screens of data to quickly find glitches, or signal losses.

NOTE

Control icon function is normal when using zoom, with the following exception:

Forward 1 Frame / Back 1 Frame control icons - (press once) moves multiple frames relative to the set magnification level (e.g. 2X setting, moves 2 frames; 16X setting, moves 16 frames).



When the **Zoom** icon is selected the display defaults to the "Max" magnification level and a dropdown scroll menu will display ([Figure 11-36](#)).

The dropdown menu allows you to select the display magnification level from a range of 1X to 512X (Max). The "Max" (maximum) option displays all data captured on one screen.

NOTE

It is important to remember that whatever sweep setting you used during data capture is what the 1X zoom level will show.

NOTE

The active zoom options (1X to 512X (Max)) that are selectable are dependent on the amount of data stored in the buffer. Less data captured = less zoom options. More data captured = more zoom options.

When zoom levels of 2X and higher are selected, a Zoom cursor (vertical dashed line) ([Figure 11-36](#)) displays onscreen. The cursor is used to quickly mark and navigate to points of interest or glitch in a captured waveform.

The Zoom cursor can be used to mark the approximate position of a glitch and can be manually dragged onscreen to the desired position. The new cursor position will be centered on the screen when a lower magnification level is selected.

Figure 11-36 shows an example at Max with the Zoom cursor positioned in the area of a signal drop glitch.

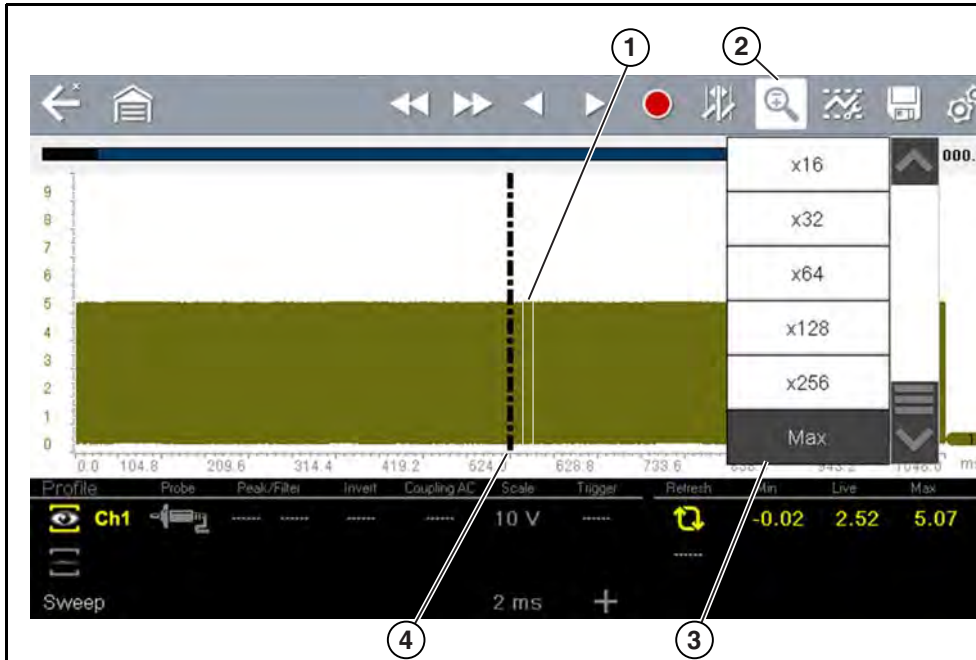

1. Glitch
2. Zoom Icon
3. Zoom Magnification Level (Max shown)
4. Zoom Cursor

Figure 11-36

NOTE

To quickly identify a glitch in a pattern, it may be easier to initially view the waveform at a higher magnification level (e.g. 256X or "Max") to display the entire captured waveform, find the area of interest and then lower the zoom level to 8X or 2X to review that area in detail. See the following figures and the [Zoom Example](#) on page 105.

Figure 11-37 shows an example at 16X of the same waveform shown in Figure 11-38. In Figure 11-37 at 16X, the glitch is easily seen as compared to higher magnification levels.

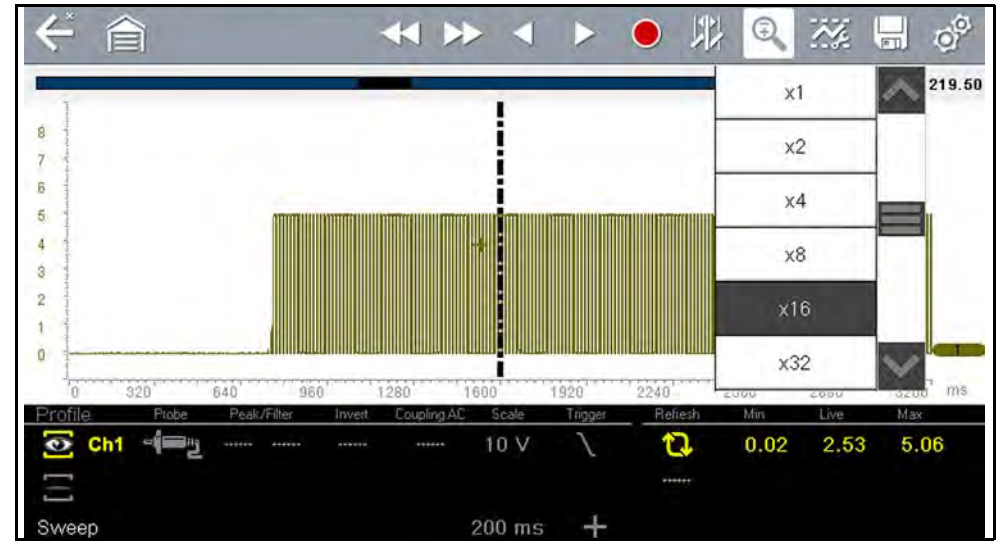

Figure 11-37

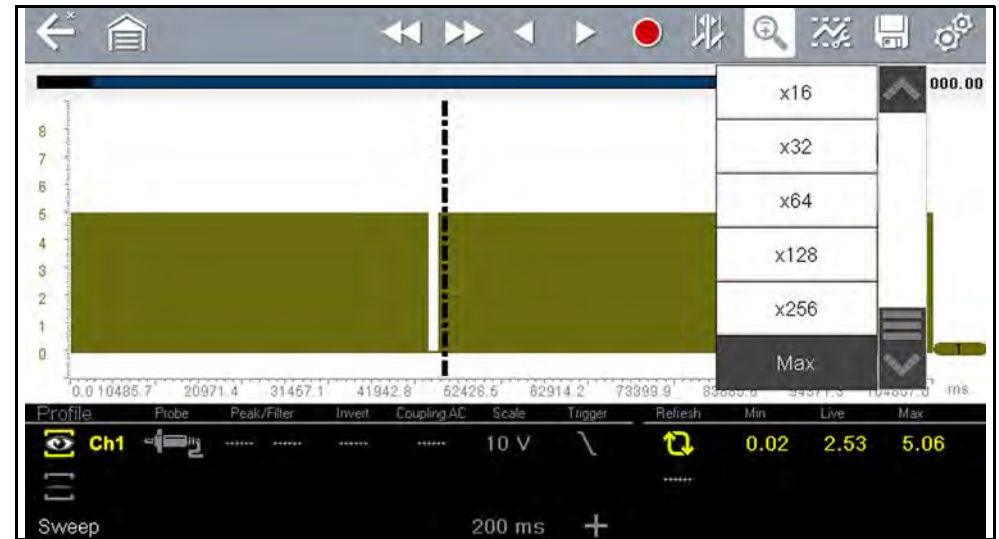

Figure 11-38

Zoom Example

While monitoring a MAF (Mass Air Flow Sensor) signal, the waveform displays normally. As the signal is being monitored, an erratic “condition” suddenly develops, then goes away, but may have not been observed on the screen. Pausing the data capture (when such an event occurs) allows you to analyze the waveform using a higher zoom level (wider view) to look for a glitch in the signal.

The following **three** illustrations show a generic square waveform to illustrate this method.

1 - Monitoring / Capturing waveform as it displays normally ([Figure 11-39](#)). You may not see a glitch, while monitoring at this setting.

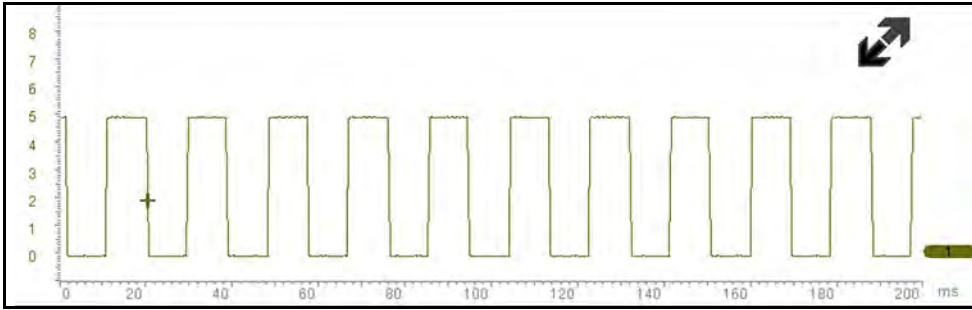

Figure 11-39

2 - Pause data capture and then zoom out (this example is at 256X) to see more data and to possibly find a glitch ([Figure 11-40](#)). In this example the cursor has been placed on the right side of a glitch. The waveform is too compressed to see any detail, however the glitch stands out as a thin light area in the waveform.

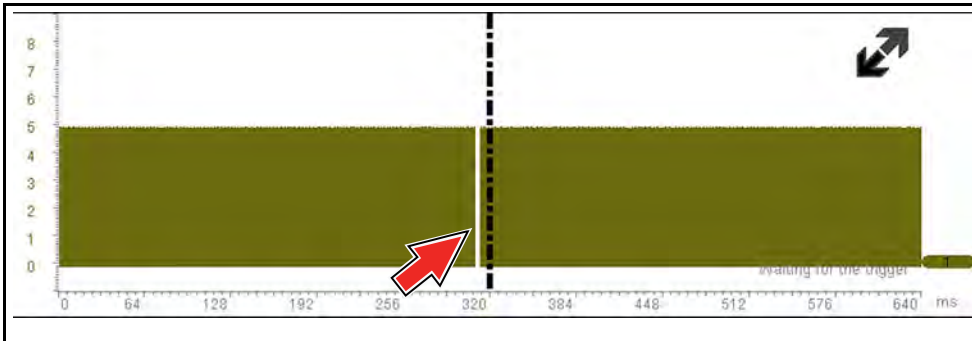

Figure 11-40

3 - Zoom back in (this example is at 8X) to view more detail ([Figure 11-41](#)) in the area where the cursor was placed by the glitch.

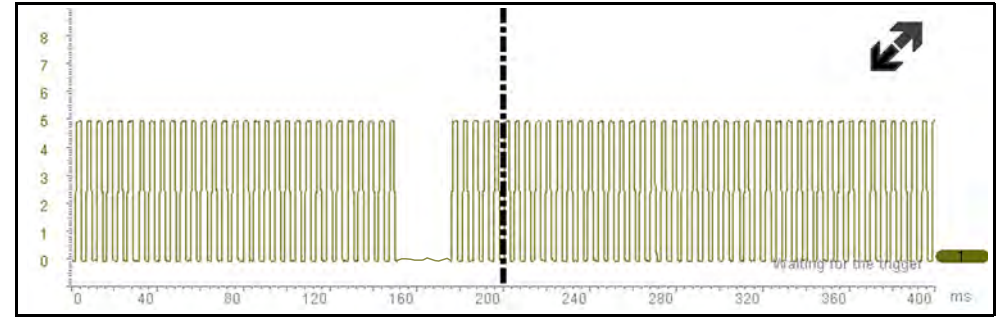

Figure 11-41

11.9 Saving Data Files

Selecting the **Save** icon writes the data stored in buffer memory to a file. Saving data files is useful when trying to isolate an intermittent problem or to verify a repair during a road test. The saved file can be played back (similar to a movie clip) by selecting **Previous Vehicles and Data > View Saved Data**. See [View Saved Data](#) on page 113 for additional information.

NOTE

The **Save icon** performs the same function as “Save Movie” function choice for the programmable **Shortcut** button, see [Configure Shortcut Button](#) on page 117 for details.

The saved file can also be downloaded to a personal computer (PC) using the Mini USB jack. Once connected to the PC, the files can be printed, transferred, and copied using ShopStream Connect. ShopStream Connect is a companion application that interfaces the diagnostic tool with a PC. ShopStream Connect is available at no cost, and can be downloaded online. See the ShopStream Connect website information at the front of this manual for additional information.

The toolbar control icons are described in [Scope Multimeter Control Icons](#) on page 82 and [Common Toolbar Control Icons](#) on page 8.

-  **To save files:**
- Select the **Save** icon from the toolbar.
- A save dialog box displays while files are being saved. The file is saved when the message box disappears.

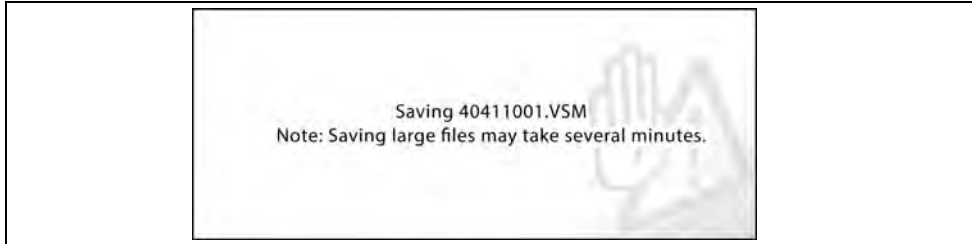

Figure 11-42 Save dialog box

11.10 Saving Screens

The **Shortcut** button can be programmed to save a snapshot (screen shot) of a visible screen as a bitmap file, see [Configure Shortcut Button on page 117](#) for details. The saved file can be viewed by selecting **Previous Vehicles and Data > View Saved Data**, see [View Saved Data on page 113](#) for additional information.

11.11 General Reference

11.11.1 Basic Setup Tips (unknown signal type)

When conducting automotive diagnostics, situations may arise when you need to capture and analyze a signal that you are not familiar with, or know what the intended waveform pattern should look like, or even how to set the scope to acquire the signal.

The following tips are intended to provide guidance, at the most basic level to assist you in your lab scope diagnostics.

Testing information and/or procedures for testing certain components may be available in the Guided Component Test function, see [Guided Component Tests on page 66](#) for additional information. If you have already narrowed down the system and/or component to test, ID the vehicle within the Guided Component Test function, and check the available tests first, as this may save you some time.

If the Guided Component Test function, does not have the test you are looking for, you need to determine a few things about what you are testing to get the scope / meter set up to capture a signal or make a measurement.

i NOTE

Testing information and known good waveform libraries may also be available from other sources. Obtaining correct testing reference information can be a key advantage in making sound repair decisions.

Listed below are a few basic questions to help narrow down the testing direction to follow.

- Are you looking to make or test a simple voltage or current level or maybe check resistance or continuity? Then you may want to use the DMM.
- Are you looking to check a circuit/component for an erratic dropout or make a frequency test? You may want to use the GMM.
- Do you need to see signal details (level, shape, frequency etc.)? The lab scope may be the best choice.
- Are you testing a DC or AC signal?
- What is the operating range of the circuit?
- Do you know what type or shape the intended waveform should be?

After answering the questions above (at a minimum), you need to determine which Scope / Multimeter test function you are going to use (e.g. Lab Scope, DMM or GMM). See [Tests and Capabilities \(Quick Reference\) on page 78](#).

Once your test function is selected, you can now connect the test leads and select the applicable probe and scales:

Probe (test) type, see [Probe \(Probe type “test” selection\) on page 87](#)

Vertical scale, see [Scale \(Vertical scale adjustment\) on page 85](#)

Sweep scale, see [Sweep \(Horizontal or Time scale adjustment\) on page 86](#)

Connect the test leads or probe, to the applicable test point(s). Always use the correct lead or probe designed for the test and ensure the signal and ground connections are clean and secure.

For the initial setup, you may wish to turn other channel settings off (e.g. Peak, Filter, Invert, AC Coupling, Threshold etc.), as these may affect the signal display. See [Channel Settings on page 88](#).



As a default setting, trigger is normally off. The scope/meter uses internal circuitry to display a signal if present. However, in certain circumstances additional channel adjustments may be required, or the trigger mode may have to be turned on, for a signal that is present but is not displayed. You may also need to readjust the vertical scale if set to low, in order to bring the signal into the viewable display area.

At this point you should have a visible signal on the screen. An ideal signal should be displayed within the area of the display.

- If the signal goes beyond the top and bottom of the display, try and readjust the vertical scale to a higher setting, to bring the signal into the viewable display area.

Use the zero baseline controls or move the zero baseline marker onscreen to move the zero baseline of the signal vertically on the screen to the desired position. See [Trace \(Zero Baseline position adjustment\)](#) on page 89.

- If the signal cycles are compressed (close to each other), try and readjust the sweep scale (horizontal scale) to a lower setting to display less cycles.

Once you have a usable signal displayed, if needed use the trigger function to stabilize a changing or erratic signal (a signal that may flicker or drift), so that it is easier to view. Try and set the trigger at the mid-point of the signal, and then adjust as needed from there. See [Trigger](#) on page 91.

As all signals are different, and due to other variables, additional adjustments may be needed to get the signal displayed exactly how you need. Review the channel settings section in this manual for additional information on using the settings. See [Channel Settings](#) on page 88.

At this point you should have a signal displayed that will allow you to see the overall signal characteristics, and allow you to begin your diagnosis.

Comparing your captured waveforms to known good waveforms, can be a time saver and provide supporting evidence when trying to determine a fault. See [Using Known Good Waveforms](#) on page 107 for additional information.

11.11.2 Using Known Good Waveforms

In some cases captured waveforms may not provide enough information to determine if a suspected sensor or circuit is at fault. Comparing the test vehicle waveforms to known good waveforms, can help to provide supporting evidence when trying to determine a fault.

Known good waveform examples may be available from different sources including the Guided Component Tests function, or from other sources.

As good practice, capturing waveforms before and after the repair will help you to build your own library of waveforms for future troubleshooting.

11.11.3 Troubleshooting Signals

When capturing signals, you may occasionally encounter problems with the way the signal initially displays. Noise, hash, fuzz are some of the terms used to describe, unwanted signals displaying in or on the signal you are trying to capture, basically making the signal unclear. The following tips are intended to provide some basic guidance, to help resolve these types of issues if encountered.

- Make sure you have the correct test leads connected to the applicable test point(s) and test lead jacks on the diagnostic tool.
- Ensure the signal and ground connections are clean and secure, at the test points and diagnostic tool.
- Ensure the polarity of the test leads connections are correct.
- If using stackable connectors, try to isolate or only connect the leads being used to capture the signal.
- Make sure the ground lead is providing a direct ground from the circuit to the diagnostic tool test lead jack.
- Isolate the test leads from other components, leads, or systems that may induce unwanted noise into the signal being tested (e.g. electric motors, secondary ignition components, relays, alternators, etc.)
- Use the shortest test leads possible.
- Try different test leads, to verify the issue. Use the recommended snap-on leads or probes available for the diagnostic tool or equivalent. Shielded test leads are recommended.
- Check the test lead or probes for damage.
- Enable or disable channel controls also to help try and clean the signal:
 - **Peak Detect**—maximizes sampling rate, but may pickup unwanted noise
 - **Filter**—removes signal noise or interference
 - **Invert**—switches signal polarity
 - **Coupling AC**—blocks the DC portion of signal
 - **Threshold** —provides a more accurate measurement on select GMM tests where noise is present
 - **Scale (Vertical scale adjustment)**—adjusts vertical scale. Using a higher setting may provide a cleaner signal in some situations.

For signals that do not display or display off the screen, erratic, compressed etc.:

- Use a trigger to help stabilize the signal. Try and set the trigger at the mid-point of the signal, and then adjust as needed from there. See [Trigger](#) on page 91.
- If the signal wraps off the top and bottom of the display, try and readjust the vertical scale to a higher setting, to bring the signal into the viewable display area. See [Scale \(Vertical scale adjustment\)](#).
- If the signal cycles are compressed (close to each other), try and readjust the sweep scale (horizontal scale) to a lower setting to display less cycles. Try a higher setting if the cycles are spread too far across the screen and seem flat. See [Sweep \(Horizontal or Time scale adjustment\)](#) on page 86.
- Move the zero baseline marker to move the zero baseline of the signal vertically on the screen to the desired position. See [Trace \(Zero Baseline position adjustment\)](#) on page 89.
- Check calibration of test leads or probe(s) if applicable. See [Test Lead / Probe Calibration](#) on page 83.

11.11.4 Units of Measurement / Conversions

Base Units	
(Symbol) / Unit Prefix	Typical Expressions
(μ) micro	0.000001 or 10 ⁻⁶ or 1/1,000,000
(m) milli	0.001 or 10 ⁻³ or 1/1,000
(c) centi	0.01 or 10 ⁻² or 1/100
(k) kilo	10 ³ or 1,000
(M) mega	10 ⁶ or 1,000,000

Electrical Units	
(Symbol) / Description	Equivalents
(V) Voltage	$V = I \times R$
(I) Current	$I = V \div R$
(R) or (Ω) Resistance	$R = V \div I$
(Hz) Frequency	$f(\text{freq.}) = 1 \div T(\text{time})$ or 1 cycle per second
Voltage	
(μV) microvolt	1 μV = 0.000001 V
(mV) millivolt	1 mV = 0.001 V
(V) volt	1 V = 1000 mV
(kV) kilovolt	1kV = 1,000 Volts.
Ohms	

Electrical Units	
(Symbol) / Description	Equivalents
(mΩ) milliohm	1 mΩ = 0.001 ohms
(Ω) ohm	1 Ω = 1000 mΩ
(kΩ) kilohm	1 kΩ = 1000 Ω
(MΩ) megaohm	1 MΩ = 1,000,000 Ω
Amperes	
(μA) microamps	1 μA = 0.000001 amps
(mA) milliamps	1 mA = 0.001 amps
(A) amps	1A = 1000 mA
(ka) kiloamps	1 ka = 1000 amps
Frequency	
(MHz) megahertz	1 MHz = 1,000,000 Hertz
(kHz) kilohertz	1 kHz = 1000 Hertz

Pressure Units	
(Symbol) / Description	Equivalents
(psi) pounds per square inch	1 psi = 6894.757 Pa 1 psi = 0.06894757 bar 1 psi = 2.036021 inHg
(bar)	1 bar = 14.50377 psi 1 bar = 100000 Pa 1 bar = 29.52999 inHg
(Mbar) Millibar	1 Mbar = 0.001 bar
(Pa) pascal	1 Pa = 0.0001450377 psi 1 Pa = 0.00001 bar 1 Pa = 0.0002952999 inHg
(kPa) KiloPascal	1 kPa = 1000 Pa
(MPa) Megapascal	1 MPa = 1,000,000 Pa
(inHg) inches of mercury	1 inHg = 0.03386388 bar 1 inHg = 0.4911541 psi 1 inHg = 3386.388 Pa

Pressure Conversions	
	psi x 0.0689 = bar
	psi x 6.8950 = kPa
	psi x 0.0703 = kg/cm ²



Pressure Conversions
bar x 14.5030 = psi
bar x 100.0000 = kPa
bar x 29.5300 = inHg (60°F)
kPa x 0.1450 = psi
kPa x 0.0100 = bar
kPa x 0.0102 = kg/cm ²
kPa x 0.295299 = inHg
kg/cm ² x 98.0700 = psi
kg/cm ² x 0.9807 = bar
kg/cm ² x 14.2200 = kPa
inHg (60°) x 0.0333 = bar
inHg (60°) x 3.3770 = kPa
inHg (60°) x 0.0344 = kg/cm ²
inHg x 25.4 = mmHg
mmHg x 0.003994 = inHg

Temperature Units	
(Symbol) / Description	Conversions
(°C) degree Celsius	°C = 0.556 x (°F - 32)
(°F) degree Fahrenheit	°F = (1.8 x °C) + 32

Time Units	
(Symbol) / Description	Equivalents
(μs) microsecond	1 μs = 0.000001 of a second
(ms) millisecond	1 ms = 0.001 of a second
(s) second	1 s = 1000 ms

Duty % to Dwell Conversions			
Duty Cycle	Dwell		
%	4 cyl	6 cyl	8 cyl
10	9.0	6.0	4.5
20	18.0	12.0	9.0
30	27.0	18.0	13.5
40	36.0	24.0	18.0

Duty % to Dwell Conversions			
Duty Cycle	Dwell		
%	4 cyl	6 cyl	8 cyl
50	45.0	30.0	22.5
60	54.0	36.0	27.0
70	63.0	42.0	31.5
80	72.0	48.0	36.0
90	81.0	54.0	40.5
100	90.0	60.0	45.0

11.11.5 Glossary of Common Terms

Term / Abbreviation	Description
AC	Alternating Current - electrical current that switches polarity at regular intervals.
Aliasing	An effect that causes an incorrect signal to be displayed and/or causes a trigger to malfunction, due to the input signal exceeding the sample rate of the scope.
Amperage	The strength of an electric current, expressed in amperes
Amplitude	Vertical magnitude (level or position) of a signal, or the varying quantity from its zero value.
Buffer	An electronic reservoir for temporary storage of data
Cursor	Onscreen markers used to measure time, amplitude and frequency
Coupling AC	Function used to subtract the average value of a signal so that small variations can be displayed in the waveform.
DC	Direct Current - electrical current that flows in one direction only
Delta	Difference in time between two events.
Dropout	An intermittent or unwanted, vertical fall in a signal to zero that may cause an undesired result.
Duty cycle	Measurement of the length of a signals on time. Specified as a percentage (ratio), of the total cycle time.
Dwell	Used to measure a signals on time in degrees of dwell. Commonly used to measure mixture control solenoids on carbureted feedback engines and specified in duty cycle %.
Dwell 60	Measurement of the length of a signals on time displayed on a 0 to 60 degree scale. 0° = 0%; 30° = 50%; 60° = 100%.



Term / Abbreviation	Description
Dwell 90	Measurement of the length of a signals on time displayed on a 0 to 90 degree scale. 0° = 0%; 45° = 50%; 90° = 100%.
Filter	Function used to filter or smooth out spikes and fast variations in signals.
Frequency	The number of times a signal repeats in one second. Measured in Hertz (cycles per second).
Glitch	An intermittent or unwanted, error in a signal that may cause a false or undesired result.
Grid	The graph displayed on the scope screen that is made up of the x and y axis scales that aid in the measuring of signal characteristics.
Horizontal Scale	See Sweep Scale
Invert	Function used to switch signal polarity,
Lambda (λ)	Used to represent a numerical value denoting the actual measured air/fuel ratio with respect to the ideal air/fuel ratio at stoichiometry. Lambda equals one (1) when the actual air/fuel ratio is equal to the theoretical (stoichiometric) air/fuel ratio of 14.7 (14.66) to 1. Lambda less than 1 means excess fuel; greater than 1 means excess air.
Megasamples per second (MS/s)	Sample rate unit equal to one million samples per second
Noise or Hash	Unwanted voltage, current or signal interference that is imposed on a signal.
Parasitic Voltage	Trace voltage in a circuit after the main power source is disconnected.
Peak	The maximum amplitude value present in a varying or alternating voltage. This value may be either positive or negative.
Peak Detect	Peak detect captures and evaluates all signal sample points, in order to display fast occurring events or glitches.
Pressure Transducer	Electronic device that converts pressures (negative/positive) to electrical signals.
Pulse	A signal with abrupt (fast) signal direction changes in a positive or negative direction, with consistent level and duration.
Pulse Period	One complete on and off cycle or time period.
Pulse Train	Collection of signal pulses traveling together.
Pulse Width (duration)	Measurement of a signals on time in a circuit that pulses on and off. Specified in units of time.

Term / Abbreviation	Description
Pulse Width Modulation (PWM)	A signal that continuously cycles on and off while the on-time varies within each cycle.
RMS	The RMS (root mean square) value of alternating currents and voltages is the effective current or voltage applied, rather than the peak current or voltage measurable. The AC RMS voltage value can be defined as the equivalent DC voltage of the AC voltage measured. RMS values are commonly used in AC electrical measurement, as they are more representative of DC measurements.
Sample Rate	Number of times (frequency) the scope/meter takes a sample of the signal. Specified in mega samples per second (MS/s).
Sampling	Process of obtaining a sequence of instantaneous values for a signal at regular or intermittent intervals. When a quantity of samples are collected the operational status of the device is determined.
Screen Update Rate	How often the captured data is (updated) displayed on the screen.
Signal	Detectable voltage, current, or magnetic field, by which specific information is transmitted in an electronic circuit or system.
Square Wave	A square or rectangular waveform (digital) which alternately switches high to low (on/off) for specific lengths of time, that has very fast rise and fall times.
Sweep Scale	The horizontal scale on the grid. Also referred to as time scale or x axis.
Threshold	The threshold function automatically sets a trigger and determines a threshold level in the middle of the signal range (calculated from the Min and Max measurements) to be used as a reference point to calculate the measurement.
Trace	The actual visible line displayed on the scope screen.
Trigger	A conditional function that initiates if and when a trace is drawn on the screen.
Trigger Slope	The slope that a trigger source signal must reach before the trigger circuit initiates a sweep
VAC	Volts Alternating Current
VDC	Volts Direct Current
Vertical Scale	The vertical scale on the grid or (y-axis) represents what is being measured (voltage, amperage, pressure etc.), and the unit of measurement it is being measured in.
Volt	Unit of electric potential difference.
Voltage	Electromotive force or potential difference, expressed in volts.



Term / Abbreviation	Description
Voltage (inductive) Kick	A voltage, many times higher than the applied voltage, produced by the collapsing magnetic field in a coil when the current through it is abruptly terminated.
Waveform	The graphic representation (form) of a signal over time, which the trace displays on the screen.
Zero Base Line	Reference setting or 0% level of a graph scale.



This section describes the basic operation of the Previous Vehicles and Data function.



The **Previous Vehicles and Data** icon is located on the Home screen. This function allows you to select recently tested vehicles and access saved data files.

Main Topic Links

- [Vehicle History](#) page 112
- [View Saved Data](#) page 113
- [Viewing Codes and Code Scan Results](#) page 113
- [Delete Saved Data](#) page 115

12.1 Previous Vehicles and Data Menu

The following options are available from the Previous Vehicles and Data menu:

- [Vehicle History](#)
- [View Saved Data](#) on page 113
- [Delete Saved Data](#) on page 115

12.1.1 Vehicle History

The diagnostic tool stores the identification of the last twenty-five vehicles tested, so there is no need to go through the complete vehicle identification sequence when performing a retest after repairs have been made. The oldest vehicle record is deleted when a new vehicle is identified once there are twenty-five vehicles on file.



Figure 12-1 Vehicle history list



To select from the vehicle History:

1. Select **Previous Vehicles and Data** from the Home screen.
2. Select **Vehicle History** from the menu.
A list of up to 25 previously tested vehicles displays. Each vehicle is given a unique file name. Scroll to view the entire list.
3. With the item to be opened highlighted, either select the vehicle ID or press the **Y/✓** button.
The appropriate software loads and a vehicle ID confirmation screen displays.
4. Select **OK** or press the **Y/✓** button to continue.
The System Menu for the selected vehicle displays.

12.1.2 View Saved Data

Selecting the **View Saved Data** menu option opens a list of all the saved data (movie) files and screen images that are stored in memory. Saved files are listed in chronological order by the date and time that they were created with the most recent files are at the top of the list.

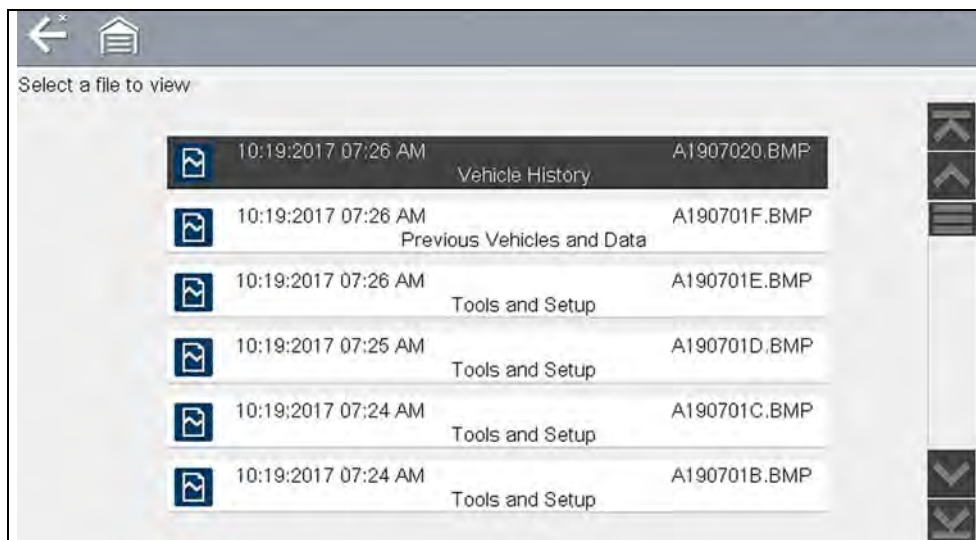

Figure 12-2 Saved data list

Selecting a file from the list, opens the file.

Saved data files can also be downloaded to a personal computer (PC) using the Mini USB jack. Once connected to the PC, the data files can be printed, transferred, and copied using ShopStream Connect. ShopStream Connect is a PC application that creates an interface between the diagnostic tool and a PC. See [ShopStream Connect™](#) on page 144.

To connect to a PC, see [Connect-to-PC \(File Transfer\)](#) on page 117.

NOTE

A maximum of 50 files are displayed. To view all (if more than 50) files stored, transfer the files to a PC and use ShopStream Connect. See [Connect-to-PC \(File Transfer\)](#) on page 117 for additional information.

▶ To review a saved data file or image:

1. Select **Previous Vehicles and Data** from the Home screen.
2. Select **View Saved Data** from the menu.
3. Select a file to review from the list.

12.1.3 Viewing Codes and Code Scan Results

When code scan or single system code results are saved, they are saved in (.XML) file format ([Figure 12-3](#)).

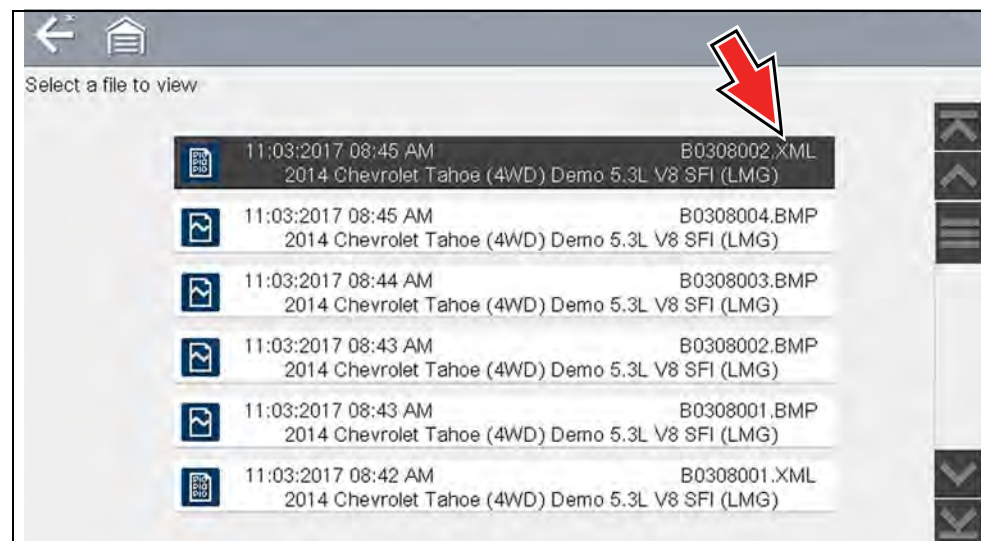

Figure 12-3 Typical - Code Results (.XML) file

Viewing the Code Scan Report on the Diagnostic Tool

Once saved, the code scan report can be viewed on the diagnostic tool in the same manner it was displayed originally.

To view the code scan report on the diagnostic tool:

1. Select **Previous Vehicles and Data** from the Home screen.
2. Select **View Saved Data**.
3. Select the code scan report .XML file from the list to view the file ([Figure 12-3](#)).

Selecting a system code or a code scan .XML file from the saved file list, opens that file onscreen ([Figure 12-4](#)).

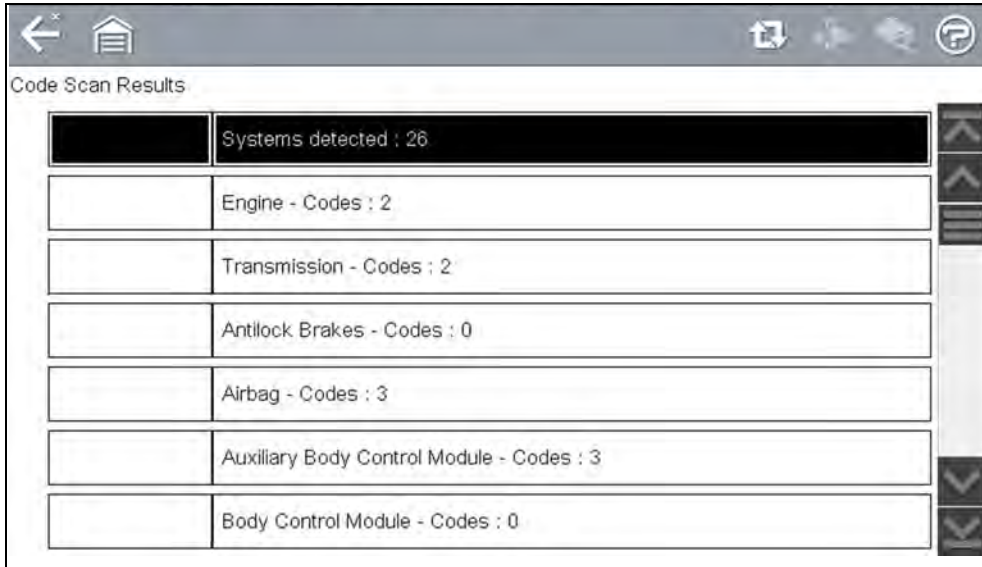

Figure 12-4 Typical - Code Scan Results (.XML file) viewed onscreen

Select the **Diagnose** icon (Figure 12-5 arrow) to open Intelligent Diagnostics. If Intelligent Diagnostics is active and data is available, additional troubleshooting information will also be displayed.

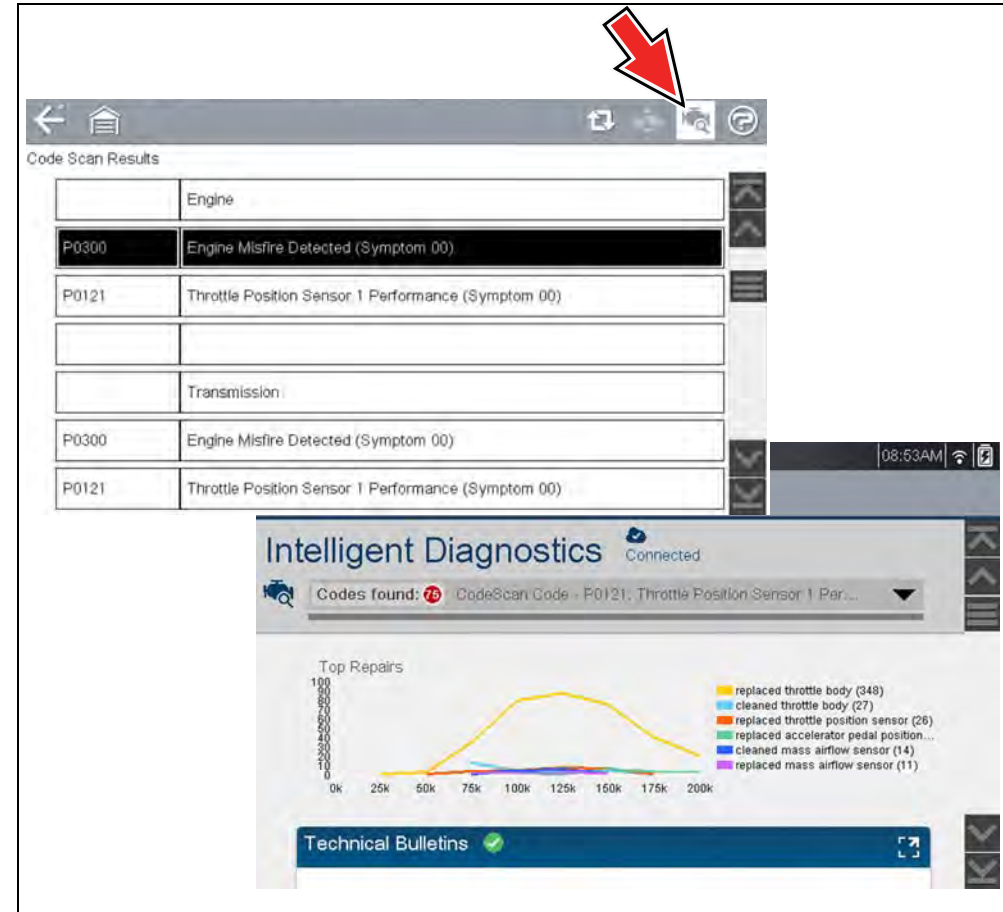

Figure 12-5

Viewing / Printing the Code Scan Report

Once saved, the code scan report can be viewed and printed using ShopStream Connect, see [Printing the \(Code Scan\) Vehicle System Report](#) on page 147.



12.1.4 Delete Saved Data

This menu option is used to permanently erase saved files from memory.



To delete a saved file:

1. Select **Previous Vehicles and Data > Delete Saved Data**.

The list of saved files displays.

Select the file(s) to be deleted using the checkboxes.

Use the **Select All / Deselect All** icon as necessary.



- 1— Select All / Deselect All Icon
- 2— Delete Icon
- 3— Selected files to be deleted

Figure 12-6

2. The files with checkboxes will be deleted. To delete the files select the **Delete** icon.
3. A confirmation message displays. Select an option:
 - **OK**—permanently deletes the selected file
 - **Cancel**—returns to the saved files list without deleting the selected file.



This section describes the basic operation of the Tools function.



The **Tools** icon is located on the Home screen. This function allows you to configure diagnostic tool settings to your preferences.

Main Topic Links

- [Connect-to-PC \(File Transfer\)](#) page 117
- [Get Connected](#) page 117
- [Configure Shortcut Button](#) page 117
- [System Information](#) page 117
- [Settings](#) page 118
 - [Configure Wi-Fi](#) page 122
 - [Configuring Scanner](#) page 122
 - [Configure Scope / Meter](#) page 123
 - [Configure Units](#) page 123
 - [High Contrast Toolbar](#) page 119
 - [Brightness](#) page 118
 - [Color Theme](#) page 119
 - [Font Type](#) page 120
 - [Backlight Time](#) page 120
 - [Touch Screen Calibration](#) page 120
 - [Time Zone](#) page 121
 - [Clock Settings](#) page 121
 - [Daylight Savings Time](#) page 121
 - [Time Format](#) page 122
 - [Date Format](#) page 122
 - [AUTO VIN](#) page 122

13.1 Tools Menu

The following options are available from the Tools menu:

- [Connect-to-PC \(File Transfer\)](#)—use to transfer and share files with a personal computer (PC)
- [Get Connected](#)—view information to register on the Snap-on Cloud
- [Configure Shortcut Button](#) on page 117—use to change the function of the shortcut button
- [System Information](#) on page 117—use to view configuration information for the diagnostic tool
- [Settings](#) on page 118—use to configure certain characteristics of the diagnostic tool



Figure 13-1 Tools menu

13.1.1 Connect-to-PC (File Transfer)

Connect-to-PC allows you to transfer saved data files on your diagnostic tool to your personal computer using a USB cable.

The optional ShopStream Connect™ PC software allows you to view, print and save data files on your PC. In addition, you can download software updates from the PC to the diagnostic tool. These features provide an ideal way to manage saved data files. The ShopStream Connect application is available free online, see [ShopStream Connect™ on page 144](#).

▶ To connect the diagnostic tool to a PC:

1. Select **Tools** from the Home screen.
2. Select **Connect-to-PC**.
A screen message displays stating that the diagnostic tool is in Connect-to-PC mode.
3. Connect the supplied USB cable to the diagnostic tool and then to the PC.
The diagnostic tool, displays as an external drive. Using Windows File Explorer locate the "USERDATA" folder to find saved screenshots (.BMP), code files (.XML), and data files (.SCM).
4. When finished, select **Exit** to return to the Tool menu, and disconnect the USB cable.

13.1.2 Get Connected

Selecting **Get Connected** allows you view the diagnostic tool serial number, PIN and Code needed to register on the Snap-on Cloud. See section [The Snap-on® Cloud on page 130](#) for registration and operation instructions.

13.1.3 Configure Shortcut Button

This feature allows you to change the function of the **Shortcut** button. Options are:

- **Brightness**—opens the brightness setting screen.
- **Save Screen**—saves a bitmap image of the visible screen.
- **Save Movie**—writes PID data from buffer memory to a file for future playback.
- **Show Shortcut Menu**—opens the menu so you can quickly select from any of the functions.
- **Toggle Record/Pause**—programs the Shortcut button to work as the Pause and Play icons.

▶ To assign a function to the Shortcut button:

1. Select **Tools** from the Home screen.
The Tools menu opens.
2. Select **Configure Shortcut button** from the menu.
3. Select a function from the menu.
4. Select the **Back** on the toolbar or press the **N/X** button to return to the options menu.

13.1.4 System Information

System Information allows you to view patent information and system information, such as the software version and serial number of your diagnostic tool.



Figure 13-2 System information

▶ To display the System information screen:

1. Select **Tools** from the Home screen to open the menu.
2. Select **System Information** from the menu.
The System Information screen displays.
3. Scroll as needed to view all of the data.
4. Select **Back** on the toolbar or press the **N/X** button to return to the options menu.

13.1.5 Settings

This Tools selection allows you to adjust certain basic diagnostic tool functions to your personal preferences. Selecting opens an additional menu that offers the following:

- System Settings - see [System Settings](#) on page 118
- Configure Wi-Fi - see [Configure Wi-Fi](#) on page 122
- Configure Scanner - see [Configuring Scanner](#) on page 122
- Configure Units - see [Configure Units](#) on page 123

System Settings

Selecting System Settings opens a menu with three options; Display, Date & Time and Auto VIN. Selecting either Display or Date & Time opens an additional menu (see below). Selecting Auto VIN provides the option to turn the Instant Vehicle ID feature on/off.

Display options include:

- [Brightness](#) on page 118—adjusts the intensity of the screen back lighting.
- [Color Theme](#) on page 119—changes the background color of the screen display.
- [High Contrast Toolbar](#) on page 119—enhances toolbar graphics for poor lighting conditions.
- [Font Type](#) on page 120—switches between standard and bold text for better visibility.
- [Backlight Time](#) on page 120—adjusts how long the screen stays on with an idle diagnostic tool.
- [Touch Screen Calibration](#) on page 120—calibrates the touch screen display.

Date & Time options include:

- [Time Zone](#) on page 121—sets the internal clock to the local time standard.
- [Clock Settings](#) on page 121—sets the time on the internal clock.
- [Daylight Savings Time](#) on page 121—configures the clock for Daylight Savings Time.
- [Time Format](#) on page 122—switches the time displays between a 12 or 24 hour clock.
- [Date Format](#) on page 122—configures how the month, date, and year displays.

Auto VIN — to turn Instant Vehicle ID feature on/off, see [AUTO VIN](#) on page 122

DISPLAY (settings)

Brightness

Selecting this option opens the brightness setting screen for adjusting the back lighting of the display ([Figure 13-3](#)).



Figure 13-3 Brightness setting

Each push of the **Plus** and **Minus** icons, or the up (▲) and down (▼) arrows, incrementally changes the back lighting up or down respectively.

Select **Back** from the toolbar or press the **N/X** button to exit.

Color Theme

This option allows you to select between a white and black background for the screen. The black background can be beneficial when working under poor lighting conditions.

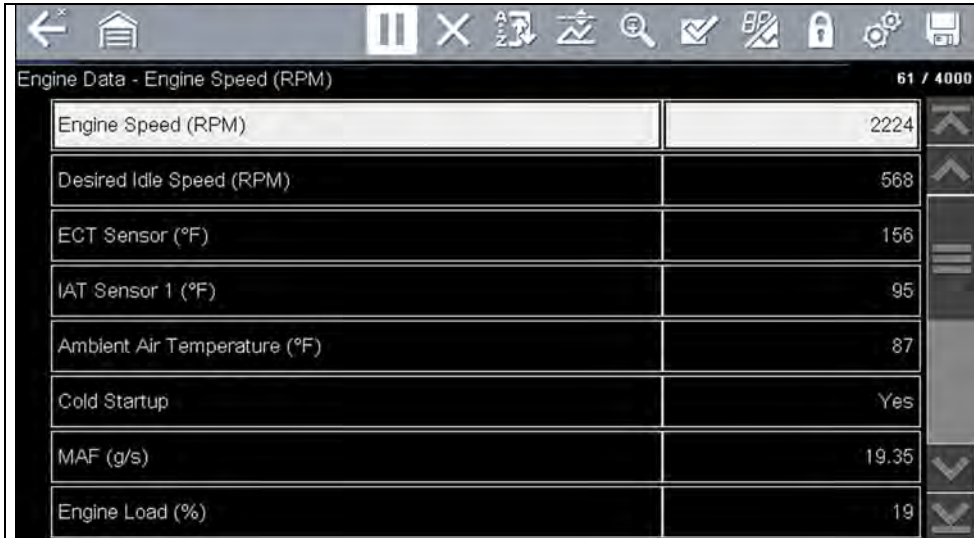

Engine Data - Engine Speed (RPM)		61 / 4000
Engine Speed (RPM)	2224	
Desired Idle Speed (RPM)	568	
ECT Sensor (°F)	156	
IAT Sensor 1 (°F)	95	
Ambient Air Temperature (°F)	87	
Cold Startup	Yes	
MAF (g/s)	19.35	
Engine Load (%)	19	

Figure 13-4 Night Theme

Selecting opens a menu with two choices: **Day Theme** (white background) and **Night Theme** (black background). Make a selection and a “please wait” message momentarily displays followed by the Home screen. The new toolbar setting is now active.

High Contrast Toolbar

This option allows you to switch to a high contrast toolbar. This toolbar features black and white icons with crisp graphics that are easier to see in poor lighting conditions or bright sunlight.

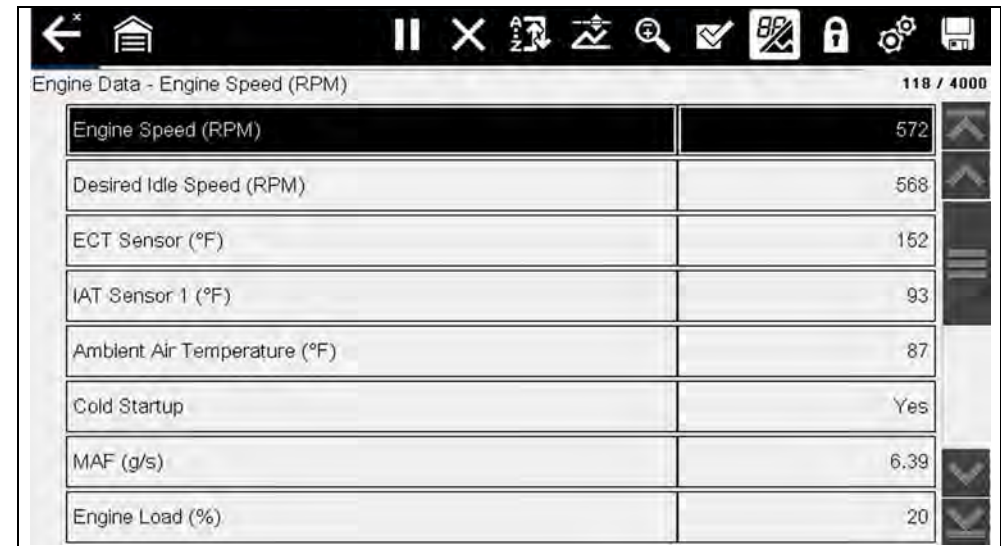

Engine Data - Engine Speed (RPM)		118 / 4000
Engine Speed (RPM)	572	
Desired Idle Speed (RPM)	568	
ECT Sensor (°F)	152	
IAT Sensor 1 (°F)	93	
Ambient Air Temperature (°F)	87	
Cold Startup	Yes	
MAF (g/s)	6.39	
Engine Load (%)	20	

Figure 13-5 High-contrast toolbar

Selecting opens a menu with two choices; Color Toolbar and High Contrast Toolbar. Select and a “please wait” message displays followed by the Home screen. The new setting is now active.



Font Type

This option allows you to select between standard and bold faced type for the display screen. Bold type makes screen writing more legible under poor lighting or bright sunlight conditions.

Selecting opens a menu with two choices: Normal Font and Bold Font. Select a menu item or scroll and then press the **Y/✓** button to make a selection. The change is instantaneous. Select the Back or Home icon on the toolbar to return to either the Settings menu or the Home screen.

Backlight Time

This option allows you to configure how long the screen backlight remains on when the diagnostic tool is inactive. The following choices are available:

- Always On
- 15 Seconds
- 30 Seconds
- 45 Seconds
- 60 Seconds

Select the menu item desired, or scroll and then press the **Y/✓** button to make a selection. Select **Back** or **Home** on the toolbar to return to either the Settings menu or the Home screen.

Touch Screen Calibration

Calibrating the touch screen maintains the accuracy of the touch-sensitive display.

IMPORTANT

To avoid serious damage to the diagnostic tool, always complete the touch screen calibration sequence once it has begun. Never turn off the diagnostic tool while a screen calibration is in process.

-  **To calibrate the touch screen:**
1. Select **Tools** from the Home screen.
 2. Select **Settings>System Settings>Display>Touch Calibration**.
The calibration screen opens ([Figure 13-6](#)).



Figure 13-6 Touch screen calibration

3. Select the center of each alignment indicator on the screen as they display in the corners of the screen, starting in the upper left corner.
 4. Once all four indicators have been selected, the verification process starts the procedure again. Select the center of each alignment indicator when prompted.
 - If the calibration is successful, the “Touch Calibration Results - Passed” screen is displayed ([Figure 13-7](#)). Press the **Y** button to complete the process and return to the Display menu.
 - If the calibration is not successful, the “Touch Calibration Results - Failed” screen is displayed. Press the **Y** button to perform the procedure again.
- The results screen ([Figure 13-7](#)) shows the entered calibration of each indicator. Ideal calibration would be to select each indicator exactly in the center, however selection inside the displayed circle is acceptable. If selecting the center is difficult using your finger, use a touch screen stylus (not included).

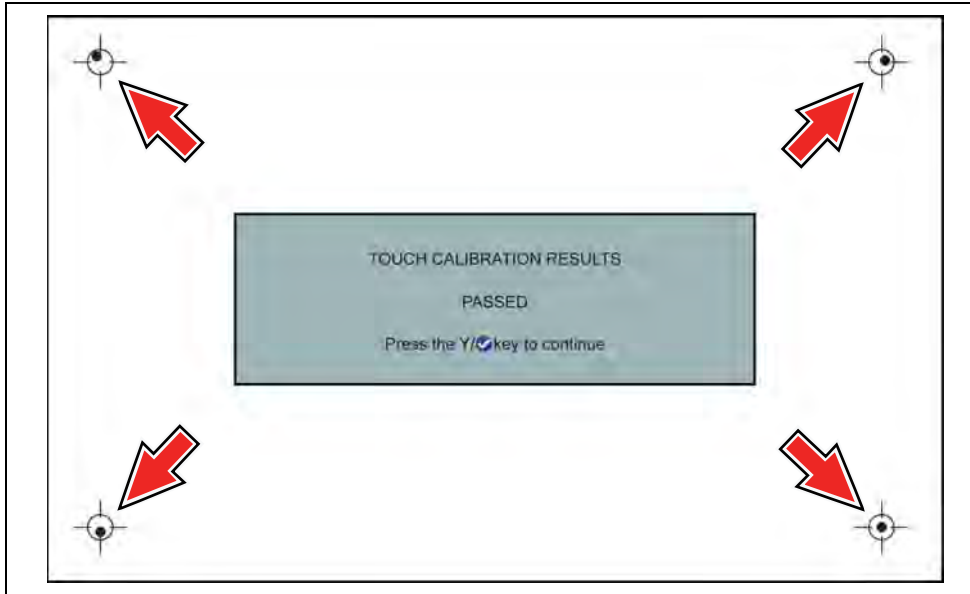

Figure 13-7 Touch screen calibration - Passed

DATE & TIME (settings)

Time Zone

This option opens a menu of time zone settings. Scroll to highlight, then select the local time zone. The display returns to the Settings menu once a time zone is selected.

Clock Settings

This option opens a window for resetting the time on the real-time clock.



To set the clock:

1. Select **Tools** from the Home screen to open the menu.
2. Select **Settings** from the menu.
3. Select **Clock Settings** from the menu.

A warning message briefly displays followed by the Clock Settings screen (Figure 13-8).

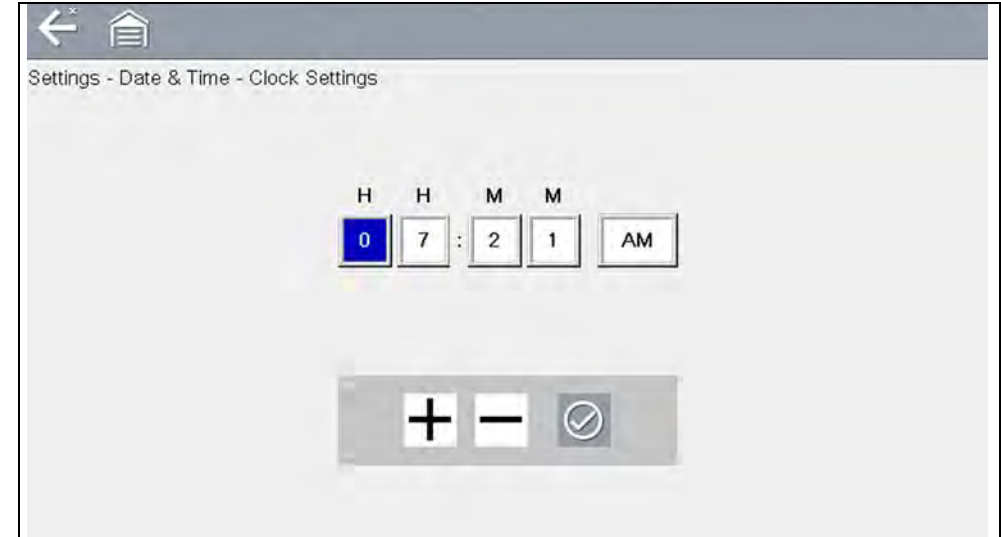

Figure 13-8 Clock settings

4. Select the **up (+)** icon on the screen or press the **up (▲)** button to incrementally increase the number in the highlighted field. Select the **down (-)** icon on the screen or press the **down (▼)** button to incrementally decrease the number.
5. Select the **check (✓)** icon on the screen or press the **Y/✓** button to move the highlight to the next field.
6. Repeat Step 4 and Step 5 until the correct time is displayed.
7. Select the **Back** icon on the toolbar or press the **N/X** button to close the Clock Settings window and return to the Settings menu.

Daylight Savings Time

This option opens a menu to configure the internal clock for Daylight Savings Time. Choose from:

- **ON**—sets the clock for Daylight Savings time.
- **OFF**—sets the clock for standard time.

Make either selection, then select the **Back** icon or press the **N/X** button to return to the menu.

Time Format

This option determines whether time is displayed on a 12 or 24 hour clock. Selecting opens a menu with two choices:

- **24 Hour Format**
- **12 Hour Format**

Make either selection, then select the **Back** icon or press the **N/X** button to return to the menu.

Date Format

This option allows you to select how date information is displayed. Select from:

- **(MM_DD_YYYY)**—Month, Day, Year
- **(DD_MM_YYYY)**—Day, Month, Year
- **(YYYY_MM_DD)**—Year, Month, Day

Make a selection, then select the **Back** icon or press the **N/X** button to return to the menu.

AUTO VIN

This option allows you to turn on/off the Instant Vehicle ID feature. See [Instant ID](#) on page 16 for information on using the Instant ID feature.

Configure Wi-Fi

Selecting **Configure Wi-Fi** allows you to configure and troubleshoot the diagnostic tool Wi-Fi connection, see [Wi-Fi Connection / Troubleshooting](#) on page 124.

Configuring Scanner

This option allows you to change the scanner display to toggle scales on and off. Scales are the graduations and values that display on the horizontal axis at the base of the parameter graphs. The waveform fills the entire graph area with scales switched off.

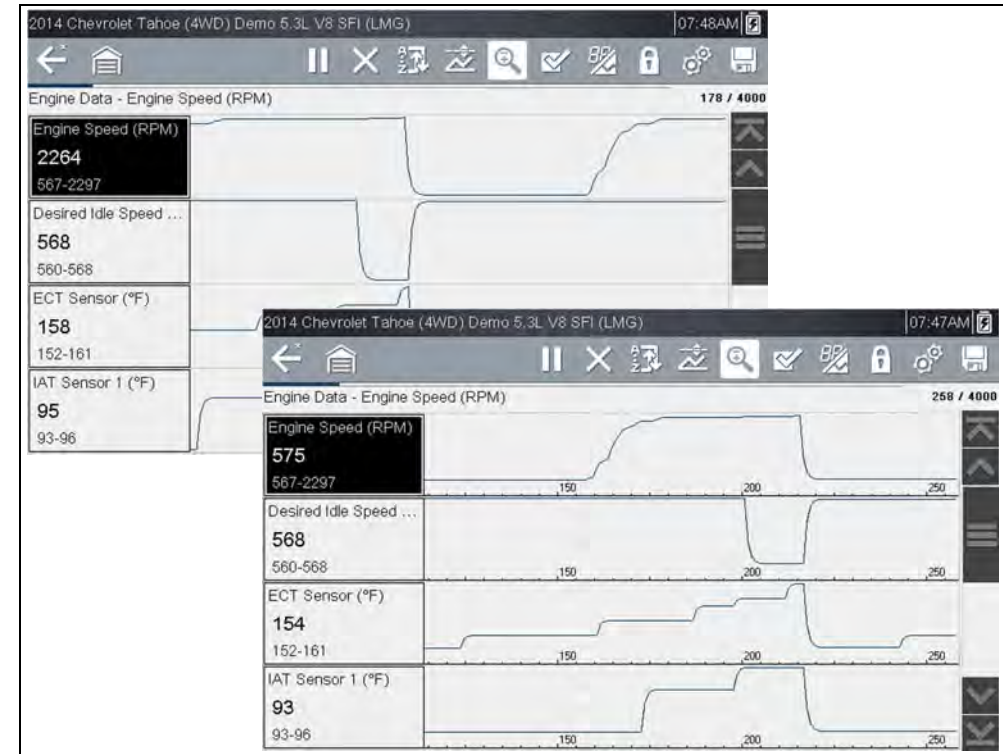

Figure 13-9 Scales hidden (upper), displayed (lower)



To change hide/show scales:

1. Select **Tools** from the Home screen.
2. Select **Settings** from the Tools and Setup menu.
3. Select **Configure Scanner** from the Settings menu.
4. Highlight either menu entry to make a selection:
 - **Show Graph Scale**—to switch the scales on.
 - **Hide Graph Scale**—to switch the scales off.
5. Select the **Back** icon or press the **N/X** button to return to the Settings menu.



Configure Scope / Meter

These menu options allow you to configure certain characteristics of the display screen to your preference when using the Scope Multimeter module.

- See [Trigger Auto/Manual Mode \(Optional Setting\)](#) on page 93 for Trigger Mode settings.
- For Display and Divisions settings, see [Optional Settings](#) on page 97.

Configure Units

Selecting opens a dialog box that allows you to choose between US customary or metric units of measure for various units.

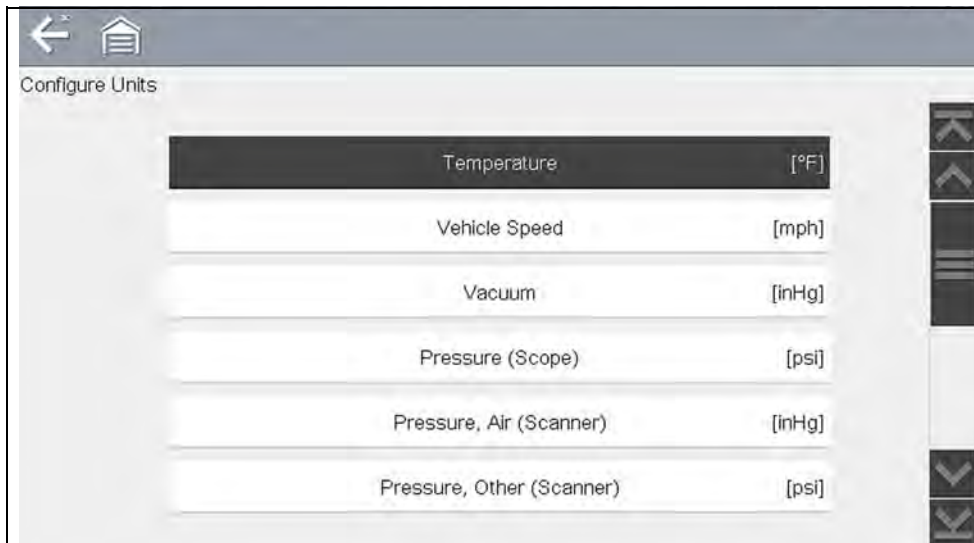



Figure 13-10 Configure units menu

-  **To change the units setup:**
1. Select **Tools** from the Home screen to open the menu.
 2. Select **Configure Units** to open the menu.
 3. Select an item from the Configure Units menu.
 4. Select a setting from the listed choices.
 5. Select **Back** on the toolbar or press the **N/X** button to return to the options menu.



The diagnostic tool is equipped with many features that require Wi-Fi connection.

The Wi-Fi connection is solely dedicated to our Snap-on Web Services Network.

To use features like the Snap-on Cloud, Intelligent Diagnostics, and TSBs, a Wi-Fi connection is required. Authorization and registration is also required to use some of these features.

This section includes information on Wi-Fi connection and troubleshooting.

Main Topic Links

- [Checking if Wi-Fi is On/Off](#) page 124
- [Checking if Wi-Fi is Connected](#) page 124
- [Turning Wi-Fi On and Connecting to a Network](#) page 125
- [Add Network Advanced \(Connecting to a hidden network\)](#) page 126
- [Wi-Fi Testing](#) page 126
- [Wi-Fi Troubleshooting and Status Messages](#) page 127

14.1 Checking if Wi-Fi is On/Off

The Wi-Fi indicator is displayed in the title bar when Wi-Fi is on.

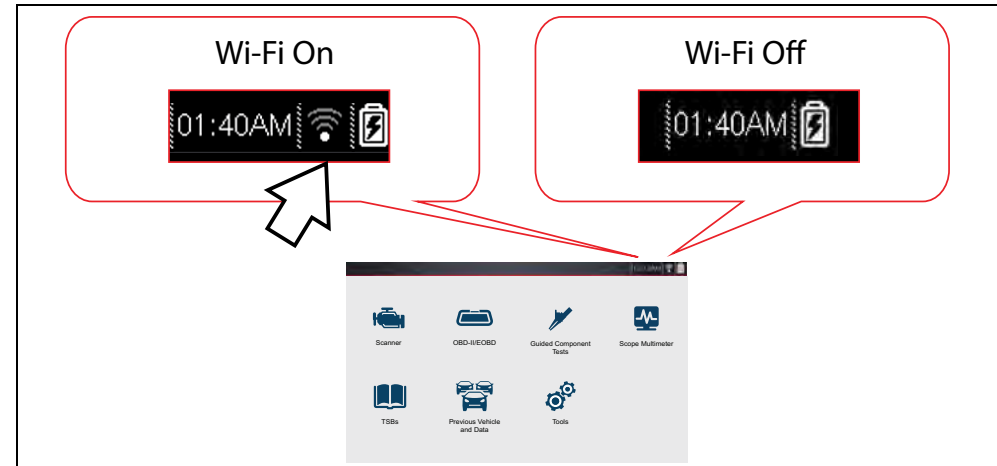



14.2 Checking if Wi-Fi is Connected

Check the Wi-Fi indicator in the title bar:

	1 to 3 solid bars - Wi-Fi is on and connected to a network. Three bars indicates maximum strength signal.
	Flashing - Wi-Fi is on, but not connected. See Wi-Fi Troubleshooting and Status Messages on page 127.
	No bars - No signal / out of range.

14.3 Turning Wi-Fi On and Connecting to a Network

- From the Home screen, select **Tools > Settings > Configure Wi-Fi**. Familiarize yourself with the following Wi-Fi icons located in the toolbar.

Wi-Fi Icon (toggle type)	Wi-Fi Test Icon
	
Indicates Wi-Fi is OFF (select to turn ON)	Select to open Wi-Fi Test screen
Indicates Wi-Fi is ON (select to turn OFF)	
Displayed on Wi-Fi configuration screen only	

- Select the **Wi-Fi icon**  to turn Wi-Fi on (Figure 14-1).

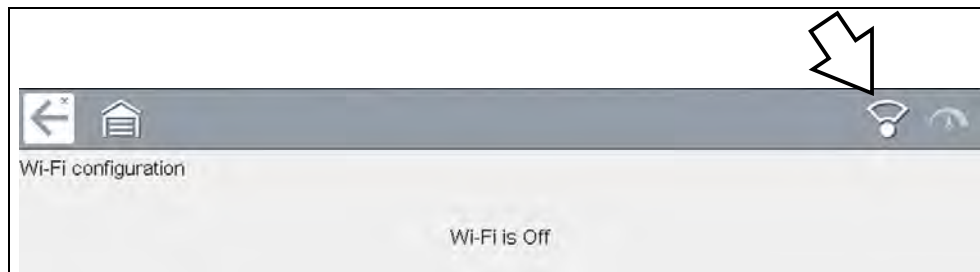



Figure 14-1 Wi-Fi Icon (shown off)

- The Wi-Fi icon will change to , indicating Wi-Fi is on. The screen will change to display available supported network connections.
- Select your network. Use the scroll feature to show all active connections (Figure 14-2).

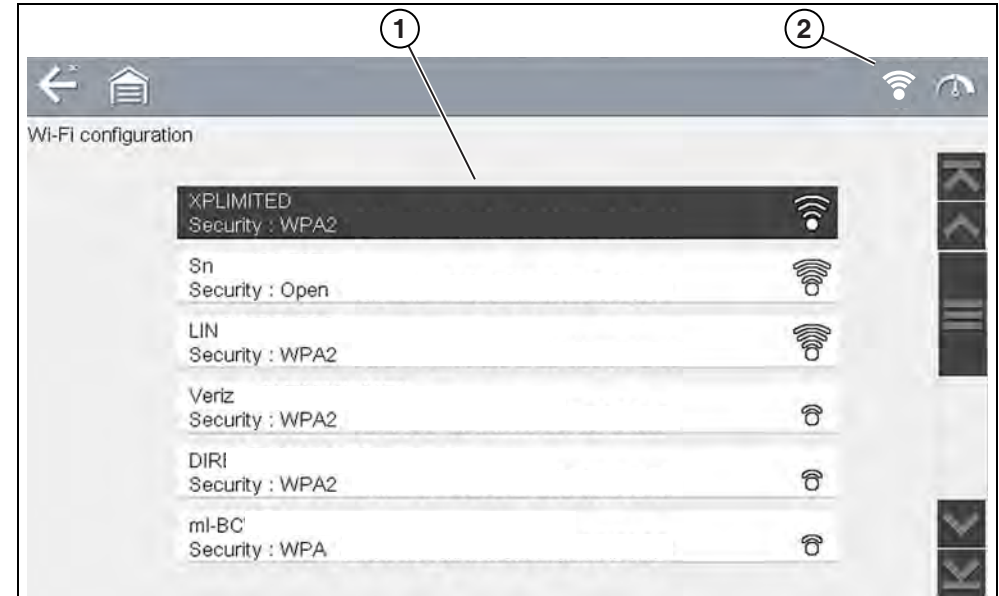

Figure 14-2 Wi-Fi Configuration Screen

- 1— Available Network Connections
- 2— Wi-Fi Icon (Wi-Fi shown on)

NOTES

A password is required when choosing a secured (protected) network. Enter the password using the on-screen keyboard and then select the check mark on the keyboard to continue.

Networks with a proxy, challenge page, or that require the user to accept terms of usage are not supported.

Wi-Fi performance varies depending on your wireless network equipment and ISP.

- Select **Connect** to connect to your desired network or **Cancel** to cancel the request.
 - From the Connect confirmation screen select **OK** to continue using this connection or **Forget** to disconnect this connection.
- The screen will change to display your confirmed network connection and Snap-on Cloud registration information. For Snap-on Cloud registration



information see [ALTUS \(ALTUSDRIVE.com\) - Cloud Sharing/Storage on page 145](#).

- If the status message “Not Connected” is displayed, retry the configuration process or see [“Wi-Fi Testing” on page 126](#) for additional information.

14.4 Add Network Advanced (Connecting to a hidden network)

The Add Network selection allows you to connect to a network that is not broadcasting its name (not visible in the displayed network list). These networks are also known as "hidden" networks.

To connect to a hidden network you will first need to know the following:

- Network Security Type
 - Open (only need SSID)
 - WPA or WPA2 (Pre-shared key)
 - WEP (WEP key)
- Network name or SSID (Service Set Identifier)
- Network Password



Connecting to a Hidden Wi-Fi Network

1. From the Home screen, navigate to **Tools > Settings > Configure Wi-Fi**.
2. Select **Add Network Advanced** from the network list (scroll to end of list).
3. Select security type Open, WPA, WPA2, or WEP. Refer to the router user manual or your IT administrator to determine the type.
4. Enter the network name or SSID
5. Enter the network password.
6. Select **Connect** at the prompt to connect to the network.
7. Select **OK** at the confirmation screen to continue using this connection, or **Forget** to disconnect this connection.

14.5 Wi-Fi Testing

If you are experiencing network connection issues, an automated testing feature is available to quickly test your network connection.



Testing Connections

1. Before you start the automated testing procedure, turn off the diagnostic tool and then turn it on. This clears previous testing messages from memory.
2. Connect to your desired network, see [“Turning Wi-Fi On and Connecting to a Network” on page 125](#).
3. From the Wi-Fi configuration screen, select the **Wi-Fi Test** icon to open the network connection test screen ([Figure 14-3](#)).

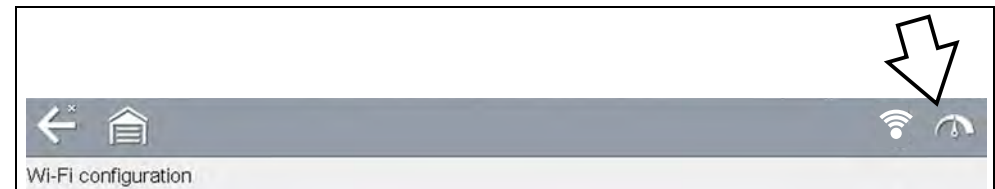

Figure 14-3 Wi-Fi Test Icon

The network connection test is an automated test that begins when the screen is displayed. Network connection systems are tested in sequence and display a status indicator

(Red = test failed, Yellow = test is process, or Green = test completed satisfactorily) when finished ([Figure 14-4](#)).

Connectivity of the following systems are checked:

- **Hardware**
- **Router**
- **Internet**
- **HTTP**
- **Web Services Network**

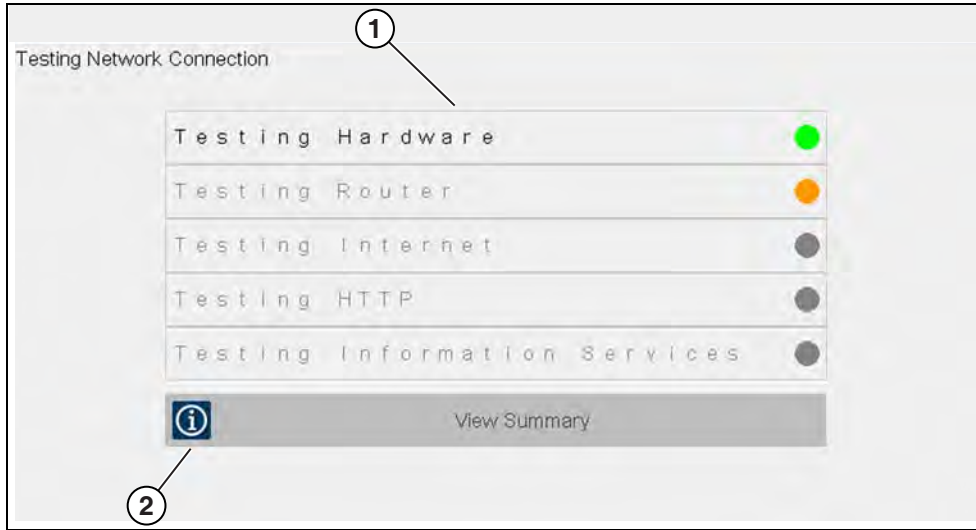

Figure 14-4 Connection Tests

1— Connection Tests

2— View Summary

- If a connection issue(s) is present, select **View Summary** to review the results. The summary information is helpful if you are experiencing difficulties with your connection (Figure 14-5). Scroll through the summary information to review the test results for each system and Tip messages for the current connection issue. See *Connection Tests - Troubleshooting* chart in “[Wi-Fi Troubleshooting and Status Messages](#)” on page 127 for additional information.

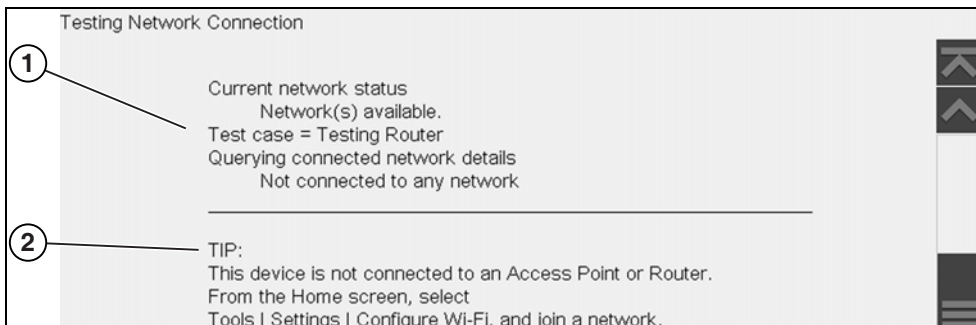

Figure 14-5 View Summary

1— Connection Test Results

2— Connection Issue Tip Message

14.6 Wi-Fi Troubleshooting and Status Messages

The following troubleshooting information is not inclusive and is meant as a guide only. Other issues and solutions may arise that are not stated here. The following description of terms are provided for reference as used in the following troubleshooting chart:

- **Router** - The data transmission device directly connected to your ISP.
- **Remote Wireless Access Point** - A wireless connection device between the router and your diagnostic tool.
- **Wi-Fi Radio** - The internal diagnostic tool radio transmitting and receiving Wi-Fi signals.
- **Network Connection** - Also called Wi-Fi connection. The configured Wi-Fi router connection the diagnostic tool connects to. This connection can be secured (password protected) or unsecured (open).

Router Information

Router compatibility and setup are important factors to check when trying to determine connectivity problems. Although we have tested this device at the factory to verify connectivity, we cannot guaranty its connectivity with your specific equipment. There may be some situations that require your time for router connection troubleshooting and/or additional consultation and equipment. Snap-on Incorporated is not responsible for any costs incurred for any additional equipment, labor or consultation charges or any other costs that may result from correcting non-connectivity issues with this device.



Check Router Settings

Verify the following router settings **BEFORE** you begin troubleshooting a non-connectivity or “No Connection” problem. After each check, make any corrections as necessary then retest for connectivity. **Contact your IT administrator or ISP for assistance.**

1. Check your router connection and if applicable, the remote wireless access point connection.
2. Clear saved Wi-Fi networks, see [Clearing Wi-Fi Networks on page 128](#).
3. Verify:
 - (a). Router is configured to use Dynamic Host Configuration Protocol (DHCP), not a static IP address.
 - (b). Router and/or settings for this device are configured to 2.4GHz. 5GHz is not supported.
 - (c). Router is configured to B/G and/or N standard wireless networks to 2.4GHz. 5GHz is not supported. See your router "User Guide" for setup, connection and troubleshooting procedures.
4. Check for router firmware and update to current version, if applicable.
5. Restart or reset the router. See your router "User Guide" for procedures.
6. Connect to a different router.

Clearing Wi-Fi Networks

1. Select the Wi-Fi network that you are trying to connect to from the list of saved networks on the Wi-Fi configuration menu.
The Wi-Fi Summary page displays.
2. Select **FORGET**
The Wi-Fi Configuration menu displays.
3. Repeat steps (1) and (2) for ALL saved Wi-Fi networks.
4. Once all saved Wi-Fi networks have been deleted (forgotten) turn off the diagnostic tool.
5. Turn on the diagnostic tool and connect to the desired Wi-Fi network, see [Turning Wi-Fi On and Connecting to a Network on page 125](#).

General - Troubleshooting		
Problem	Possible Cause	Corrective Action
Repair Information Applications (e.g. Intelligent Diagnostics, TSBs) are not available	Access has expired	Contact your sales representative.
	Access may be temporarily unavailable	Try to access the function at a later time as updates may be in process.
	Wi-Fi radio is turned Off	1. From the Home screen, navigate to Tools > Settings > Configure Wi-Fi . 2. Select the Wi-Fi icon and turn the Wi-Fi radio on. The Wi-Fi icon will change from a green check mark icon to red "X" mark icon indicating Wi-Fi radio is on. 3. Connect to a known good network.
	Not connecting to a network	1. Clear saved Wi-Fi networks, see Clearing Wi-Fi Networks on page 128 . 2. Connect to a network. 3. From the Configure Wi-Fi screen select the Wi-Fi Test icon and review the results. See Connection Tests - Troubleshooting in the following table .
Wi-Fi connection drops off or disconnects intermittently	Wi-Fi Signal strength insufficient	Check Wi-Fi signal strength - out of range or interference. Move closer (within 50 Ft. (15 M) or into a direct open sight-line of the router or if applicable, remote wireless access point. Eliminate interference from overhead lights, windows, walls, other wireless devices, metal objects and devices that emit electrostatic discharge.
	Router overloaded	Disconnect/disable other Wi-Fi devices connected to the router.



14.6.1 Informative Messages

Messages may be displayed to inform you of pending issues or general status. Depending on your access and connection status, the following are typical messages that may be displayed:

- **Content May Be Available!** - indicates content may be available, however you are not currently connected to the Web Services Network. This message may be caused by a Wi-Fi connection issue, or you do not have access to the feature. See [Wi-Fi Troubleshooting and Status Messages on page 127](#) for Troubleshooting information.
- **No connection. Please try again later.** - indicates you are not currently connected to the Web Services Network, except when displayed in the OBD/EOBD function as Repair Information Applications are not accessible in OBD/EOBD mode. If this message is displayed in the Scanner function, it may be caused by a Wi-Fi connection issue, or you do not have access to the feature. See [Wi-Fi Troubleshooting and Status Messages on page 127](#) for Troubleshooting information.
- **Loading content** - indicates information is being accessed from the Web Services Network.
- **A new diagnostic software upgrade is available. Contact your sales representative for details.**
- **Your access has expired. See your Sales representative to renew.** - indicates your access to the Web Services Network has expired and you should contact your sales representative.

Connection Tests - Troubleshooting		
Failed Test	Possible Cause (Displayed Tip Message*)	Corrective Action / Checks
Hardware	Wi-Fi radio not responding and/or will not turn off	Contact Customer Support for assistance.
	Wi-Fi radio not responding and/or will not initialize	
	Missing or corrupt firmware file(s)	
Router	This device is not connected to a router	Check Wi-Fi signal strength - out of range or interference. Move closer (within 50 Ft. (15 M) or into a direct open sight-line of the router or if applicable, remote wireless access point. Eliminate interference from overhead lights, windows, walls, other wireless devices, metal objects and devices that emit electrostatic discharge.
		Check router connection and setup. See Check Router Settings on page 128 for procedure.
Internet	This device is not connected to the Internet or has no DNS	Check router connection and setup. See Check Router Settings on page 128 for procedure.
		Domain Name System (DNS) server not connected. Contact your Internet service provider (ISP).
HTTP	This device cannot communicate using HTTP	Check if your Internet access uses a "Proxy" or "Accepting terms in a browser" protocol, or uses a challenge page. These protocols are not supported by this device. Contact your IT administrator or ISP for options.
Web Services Network (e.g.access to Intelligent Diagnostics, TSBs)	Your access has expired	Contact your sales representative.
	Repair Information Services may be temporarily unavailable or Not connecting to a network	Try to access at a later time as Repair Information Services may be performing updates to the service. Check router connection and setup. See Check Router Settings on page 128 for procedure.
* See Wi-Fi Testing on page 126 for additional information.		



This diagnostic tool includes a built-in feature that automatically transfers code scan reports to the Snap-on Cloud.

The Snap-on Cloud is a mobile-friendly cloud-based application designed specifically for technicians to store, organize and share information.

See [Vehicle Code Scan](#) on page 40 for information on using Code Scan.

Main Topic Links

- [Registration - Getting Started](#) page 130
- [Using the Snap-on Cloud](#) page 132
 - [Snap-on Cloud - New User Registration](#) page 131
 - [Logging in to Snap-on Cloud \(registered user\)](#) page 132
 - [Navigating Snap-on Cloud \(Toolbars\)](#) page 133
 - [My Files](#) page 133
 - [Search](#) page 137
 - [Shop Files](#) page 137
 - [Favorites](#) page 139
 - [Profile](#) page 139
 - [Sharing/E-mail an Individual File \(Link icon\)](#) page 135
 - [Using Profile Manager](#) page 141
 - [My Network](#) page 140
 - [Logging Out of The Snap-on Cloud](#) page 143

15.1 Key Features

- Automatically transfer code scan reports to The Snap-on Cloud.
- Access and manage your Snap-on Cloud account, using your mobile device or PC.
- Share/send files via e-mail, or other mobile apps.
- Tag files (attach a descriptive key-name) to help you organize and search files.
- Use the Search function to quickly find files by Tag, Description and Title.

15.2 Important Notes

- To use The Snap-on Cloud, account setup and diagnostic tool Wi-Fi connection is required.
- The Snap-on Cloud is continuously monitored for inappropriate content. Abuse (as determined by moderator) will result in account deactivation.

15.3 Registration - Getting Started

To use The Snap-on Cloud:

- The diagnostic tool must be connected to a Wi-Fi network
- Account registration is required online
 - If you are a new user, you will need to create a new account, see [Snap-on Cloud - New User Registration](#).



15.3.1 Snap-on Cloud - New User Registration

 If you are a new user, follow these steps to register and create a new account:

NOTE

Account setup is only required one time.

1. Connect the diagnostic tool to a Wi-Fi network, see [Configure Wi-Fi](#) on page 122.
2. Write down the Serial Number, PIN and Code that are displayed when the device connects to the Wi-Fi network ([Figure 15-1](#)), or leave the screen displayed. Registration information can also be found in the Tools menu, see [Snap-on Cloud Setup Information Screen](#) on page 132.



Figure 15-1

NOTE

The PIN and Code numbers will change each time you view the Setup screen ([Figure 15-2](#) and [Figure 15-1](#)). This is normal, any displayed set of PIN and Code numbers may be used to register.

3. Using a mobile device or PC, visit <https://ALTUSDRIVE.com> and select **Create Individual Account** from the Login screen.
4. Enter the required information and create a **Username** and **Password**, then select **Create**.
5. At the “Success” confirmation screen, select **Done**.
6. Log in using your **Username** and **Password**.
7. Answer the security questions, then select **Submit**.
8. From Technician Profile Manager select the **Device Management** tab.

9. Select **Add Device**, then enter your **Serial Number**, **PIN**, **Code**, and Device Name and select Save when done.
10. Log out of Profile Manager, then select the **ALTUS Home Page** browser tab to get started.
11. Turn the diagnostic tool off, and then on.
12. See [Using the Snap-on Cloud](#).

Your Diagnostic diagnostic tool is now registered to your Snap-on Cloud account. Code scan reports will be automatically sent (only when connected to Wi-Fi) to your online account from the device.

NOTE

If the device is not connected to a Wi-Fi network when the code scan is performed, the report will not be sent to your account. Wi-Fi connection is required to upload the report to The Snap-on Cloud.



15.3.2 Snap-on Cloud Setup Information Screen

From the Home screen, selecting **Tools > Get Connected** allows you view (Figure 15-2) the diagnostic tool serial number, PIN and Code needed to register.

NOTE

The PIN and Code numbers will change each time you view the Setup screens (Figure 15-2 and Figure 15-1). This is normal, any displayed set of PIN and Code numbers may be used to register.

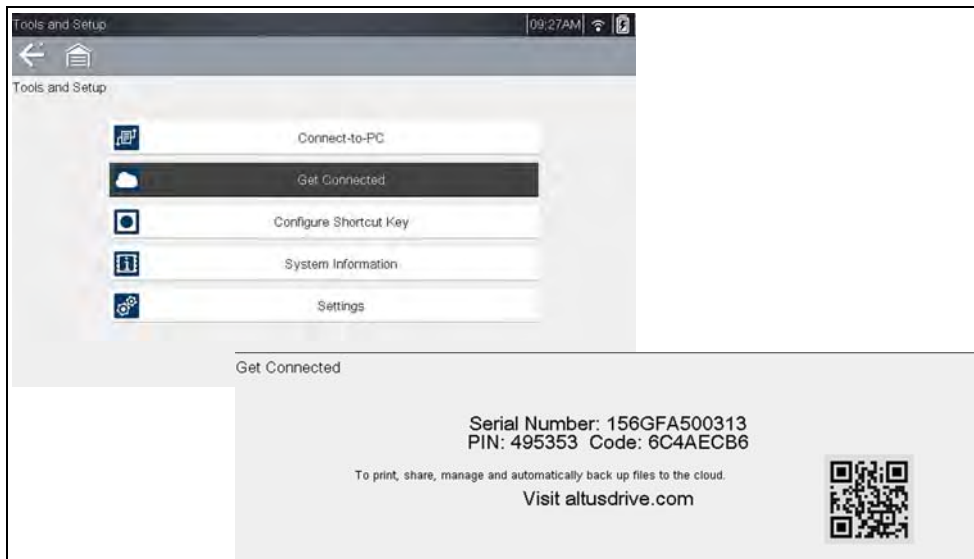

Figure 15-2

15.4 Using the Snap-on Cloud

To use The Snap-on Cloud:

- A Snap-on Cloud account is required, see [Registration - Getting Started](#) on page 130.
- The diagnostic tool must be connected to a Wi-Fi network, see [Wi-Fi Connection / Troubleshooting](#) on page 124.

15.4.1 Logging in to Snap-on Cloud (registered user)



Logging in to Snap-on Cloud (registered user):

1. Using your mobile device or PC visit ALTUSDRIVE.com.
2. Select the **Login** icon (Figure 15-3).

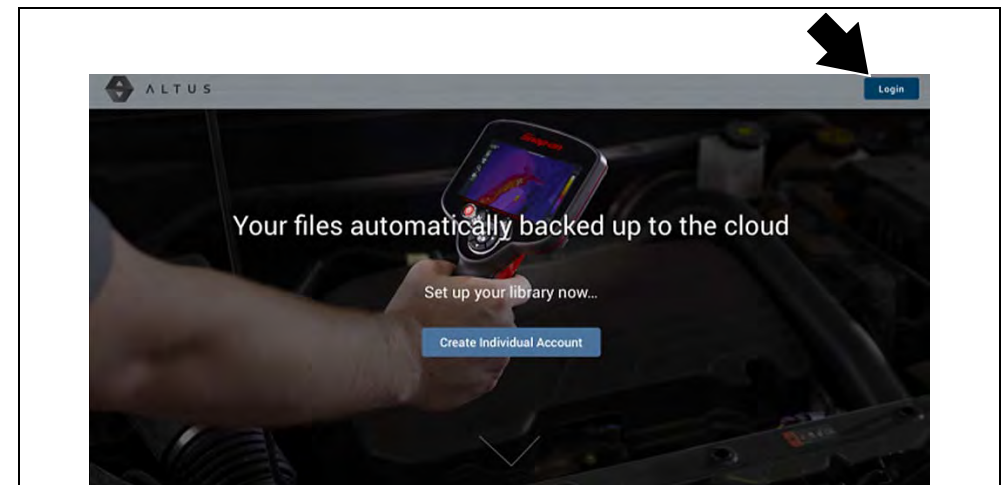

Figure 15-3

3. Log in using your **Username** and **Password** (Figure 15-4).

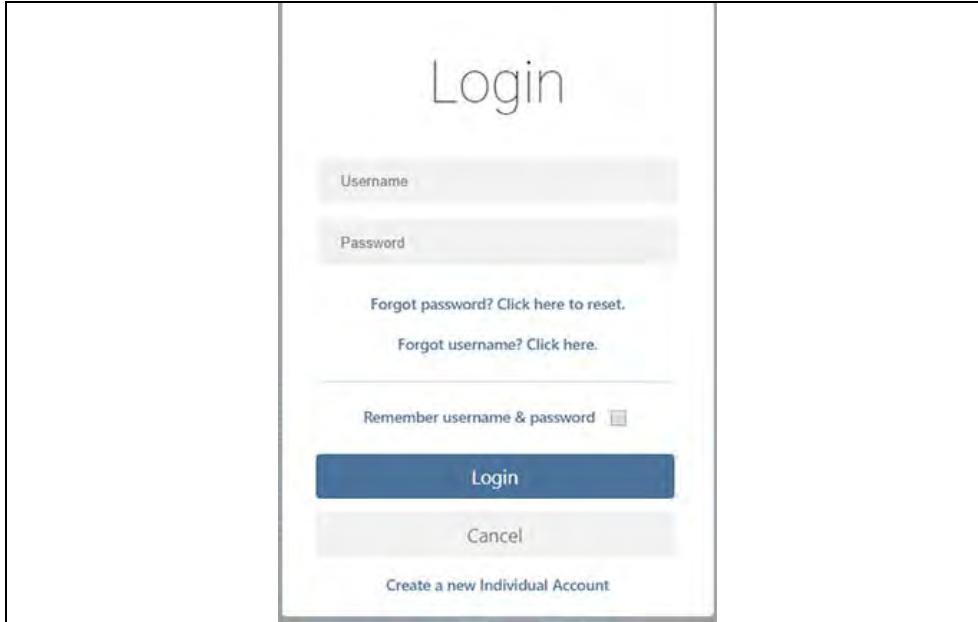

Figure 15-4

15.4.2 Navigating Snap-on Cloud (Toolbars)

The upper and lower toolbars are available from all screens.

The upper toolbar includes a menu icon (right side) (Figure 15-5). This menu allows you to share your entire gallery, see [Sharing all Files \(Share My Gallery\)](#) on page 136.



Figure 15-5

The lower toolbar (Figure 15-6) includes the following links:

- [My Files](#), see page 133
- [Search](#), see page 137

- [Favorites](#), see page 139
- [Profile](#), see page 139



Figure 15-6

15.4.3 My Files

My Files displays all the files uploaded from the diagnostic tool (Figure 15-8). Each file is displayed in a navigation card.

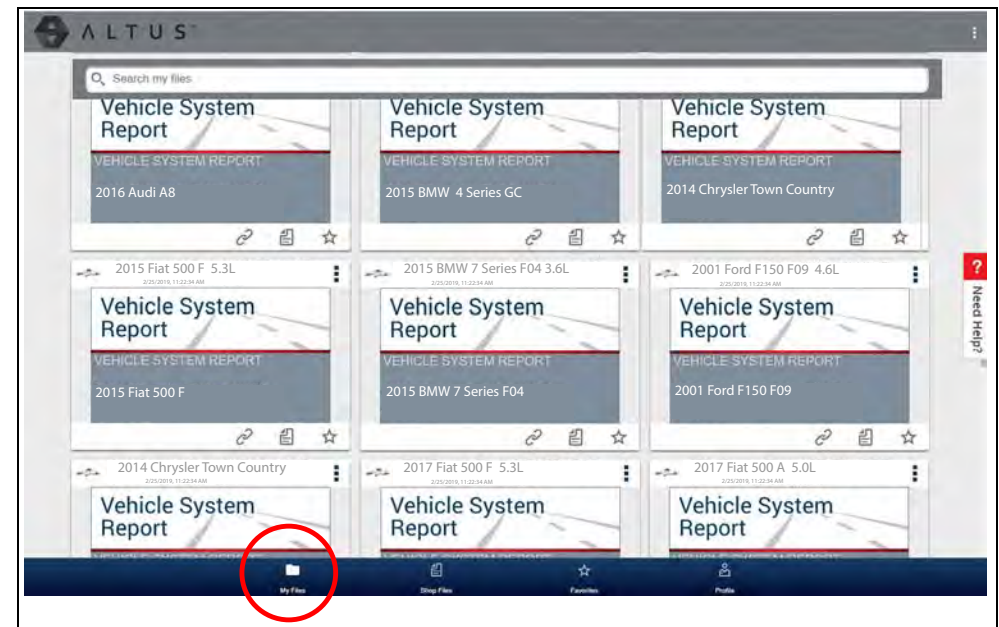

Figure 15-7

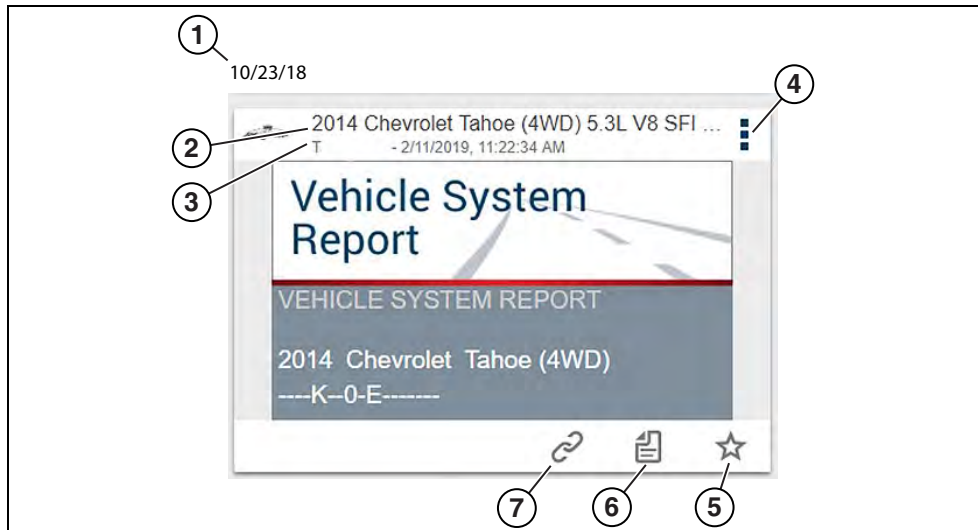

Figure 15-8

- 1— **File Upload Date** - Files are displayed with the most recent uploads at the top. The file upload date is displayed at the upper left. The date is shown once at the top of the series of files, scroll up / down to see all files within a specific date.
- 2— **File Name** - See [File Detail \(Tags\)](#) on page 134 for additional information.
- 3— **Your Account Username (and timestamp)** - See [Account](#) on page 141 for additional information. The timestamp indicates the date/time the file posted.
- 4— **Menu Icon** - options:
 - **Download** - Select to download the file to your device.
 - **Delete** - Select to delete the file from The Snap-on Cloud.
- 5— **Favorites Icon** - See [Favorites](#) on page 139 for additional information.
- 6— **Shop Files** - See [Shop Files](#) on page 137 for additional information.
- 7— **Link icon** - See [Sharing/E-mail an Individual File \(Link icon\)](#) on page 135 for additional information.

Selecting a file opens the File Details. The File Detail screen allows you to edit file metadata. See [File Detail \(Tags\)](#) on page 134.

File Detail (Tags)

As shown in [Figure 15-10](#) selecting (touching) a file from My Files opens the File Detail card. Selecting the file again opens that file in a new browser tab.

NOTE

Opening the file in a separate browser tab may allow you to use the browser viewer tools to print or download the file. This feature may not be available in all browsers.

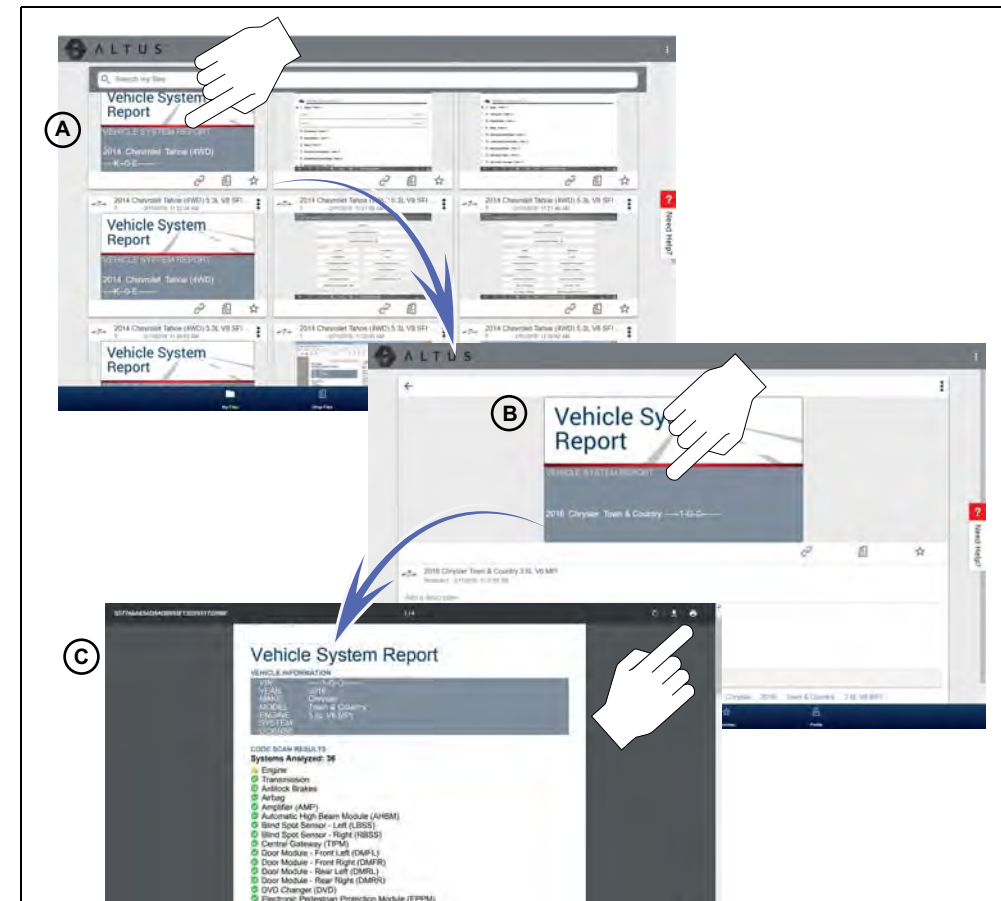

Figure 15-9

The following describes File Detail card features.

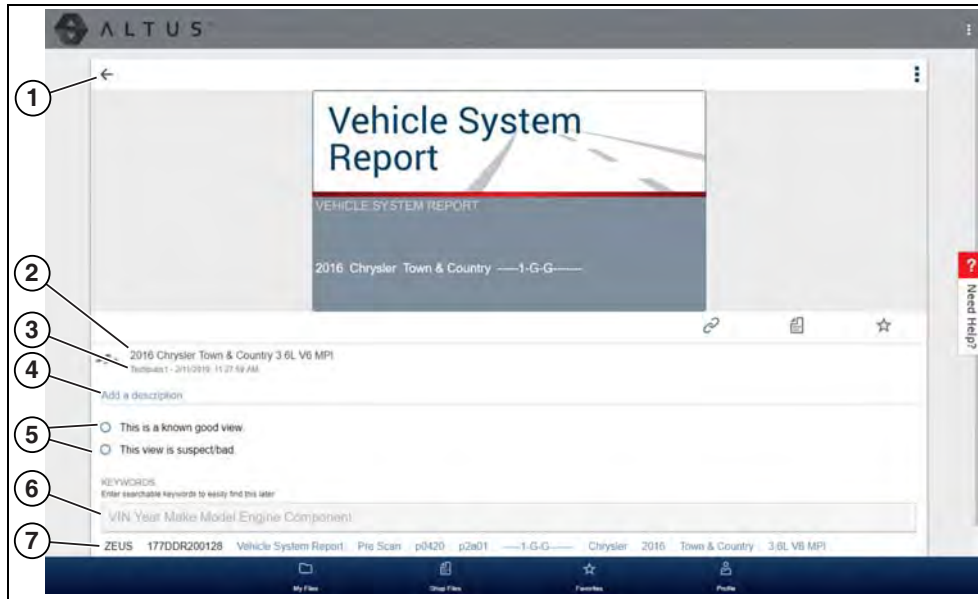

Figure 15-10

- 1— **Back Icon** - Returns to My Files
- 2— **File Name** (user entered searchable text) - Select the file name to open the editor. Enter text (alphanumeric) in the field as desired.
- 3— **Your Account Username (and timestamp)** - See [Account](#) on page 141 for additional information. The timestamp indicates the date/time the file posted.
- 4— **Description** (user entered searchable text) - Enter text (alphanumeric) in the description field as desired.
- 5— **Known Good / Bad Checkboxes** (user defined and searchable) - Selecting a checkbox automatically creates a tag (e.g. #good) and is displayed in the Active Tag(s) field.
- 6— **Tag** (user entered searchable text) - Enter text (alphanumeric) in this field as desired. Tagging a file allows you to associate (tag) descriptive text to a file. Tagging can be used to associate multiple files with a common tag. The tag text then can be used when performing a search to find all files with the same tag. Each text entry (word) that is separated by a space (return) is added as a tag, and is displayed in the Active Tag field.
- 7— **Active Tag(s)** - Displays the active tag(s). Tags can include the “good” or “bad” entry from the Known Good / Bad checkboxes, and text entered in the

file Name, Description and Tag fields. Each entry is automatically preceded with the “#” symbol.

Sharing/E-mail an Individual File (Link icon)

To share a file:

1. Select the **Link icon** ([Figure 15-11](#)) on the file card.



Figure 15-11

2. Choose an option how to send the file ([Figure 15-11](#)).

i NOTE

Some selections may be grayed out or not shown, indicating the option is not supported on your device/system.

- **Select a Link from your Network** - see [My Network](#) on page 140 for information on how to add contacts.
- **Send via SMS** (Short Message Service) - this option is used with supporting mobile devices, and will typically open a new text message with the link attached, ready to be sent.
- **Send via Email** - your system default e-mail application will open a new message with the link attached, ready to be sent.
- **Copy to Clipboard** - open your (e-mail, text, social media, etc.) application and paste the URL into a message to share with others.

The pasted URL link that is sent only displays:

- The File
- File Name
- Your User Name
- Date File was posted
- File Description



Figure 15-12

Sharing all Files (Share My Gallery)

To share your entire gallery (all files in My Files):

1. Select the **Menu** icon (*Figure 15-14*) from the upper toolbar.



Figure 15-13

2. Select **Share My Gallery**.
3. Select **Copy to Clipboard** (*Figure 15-14*) from the pop-up window.

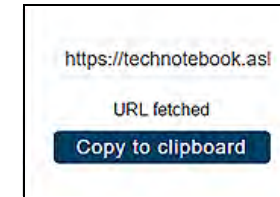

Figure 15-14

4. Open your (e-mail, text, social media, etc) app and paste the URL into a message to share with others.

The URL link that is sent is only displays:

- The Files
- File Names
- Your User Name
- Date the Files were posted
- Files Descriptions

15.4.4 Search

The Search screen allows you to perform text searches on all uploaded files and view the results.

To search for a specific file or set of files, enter a **search term** in the search box and select the **magnifying glass** icon (Figure 15-15) (or press Enter).



Figure 15-15

Search queries the following to find results:

- **File Name** - name can be either system assigned or user assigned
- **Known Good / Bad Checkboxes** - selecting a checkbox automatically creates a searchable tag (e.g. good or bad)
- **Description** - user entered text
- **Tag** - user entered text

See [File Detail \(Tags\)](#) on page 134 for additional information on the above “user entered” text.

15.4.5 Shop Files

Shop Files allows you to share a file(s) with others via e-mail, text, social media, etc, from a permanent location in the cloud. Unlike sharing a file(s) from My Files, the link is permanent and will work, even if the original file is deleted.

Shop Files links are useful when sharing a file with a customer that is not a registered Snap-on Cloud user, that just needs to see the file, and/or may need access to the file in the future.

Note: The file details displayed in a shared link will be different depending if the message recipient is logged into The Snap-on Cloud or not. If the recipient is not logged in, only limited details are displayed.

To add a file(s) to Shop Files:

From [My Files](#), select the **Copy icon** (Figure 15-16) on the file card to copy the file to Shop Files. This copies the file to a permanent location in the cloud.

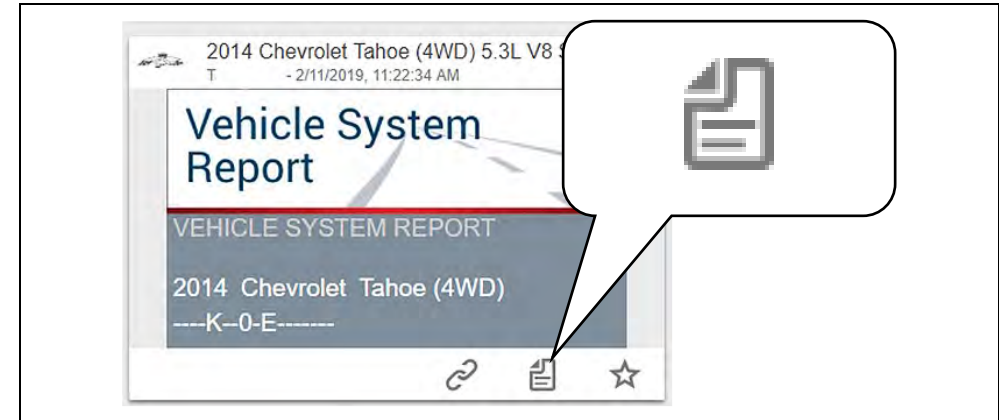

Figure 15-16

To share an individual Shop File:

1. From [Shop Files](#), select the **Copy icon** (Figure 15-17) on the file card.

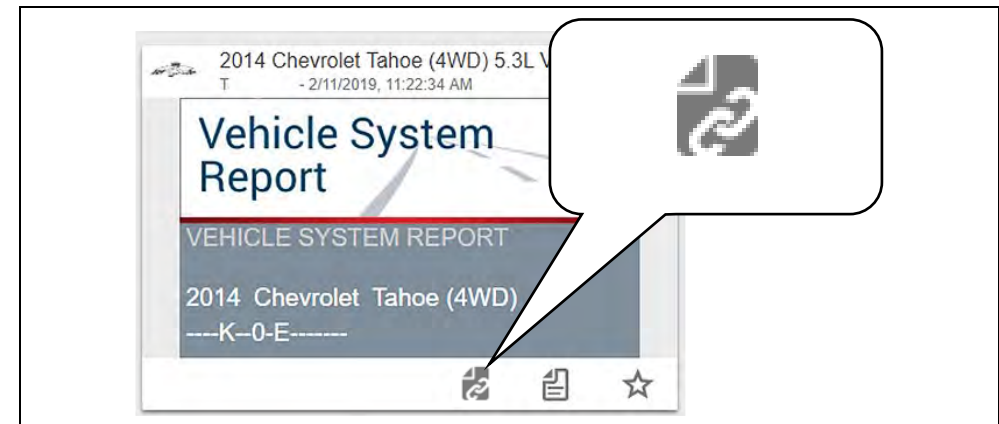

Figure 15-17



2. Select an option ([Figure 15-18](#)) from the pop-up window.

NOTE

Some selections may be grayed out or not shown, indicating the option is not supported on your device/system.



Figure 15-18

- **Select a Link from your Network** - see [My Network](#) on page 140 for information on how to add contacts.
- **Send via SMS** (Short Message Service) - this option is used with supporting mobile devices, and will typically open a new text message with the link attached, ready to be sent.
- **Send via Email** - your system default e-mail application will open a new message with the link attached, ready to be sent.
- **Copy to Clipboard** - open your (e-mail, text, social media, etc.) application and paste the URL into a message to share with others.

To share all files in Shop Files:

1. From Shop Files, select the **Menu** icon ([Figure 15-19](#)) from the upper toolbar.

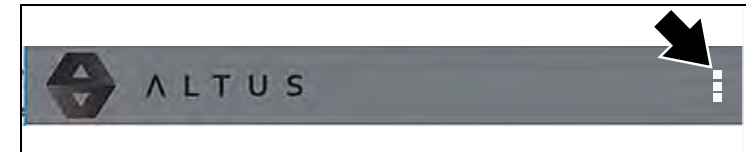

Figure 15-19

2. Select **Share My Shop Files**.
3. Select **Copy to Clipboard** ([Figure 15-20](#)) from the pop-up window.



Figure 15-20

4. Open your (e-mail, text, social media, etc) application and paste the URL into a message to share with others.



15.4.6 Favorites

The Favorites screen displays all the files selected as favorites (Figure 15-21).

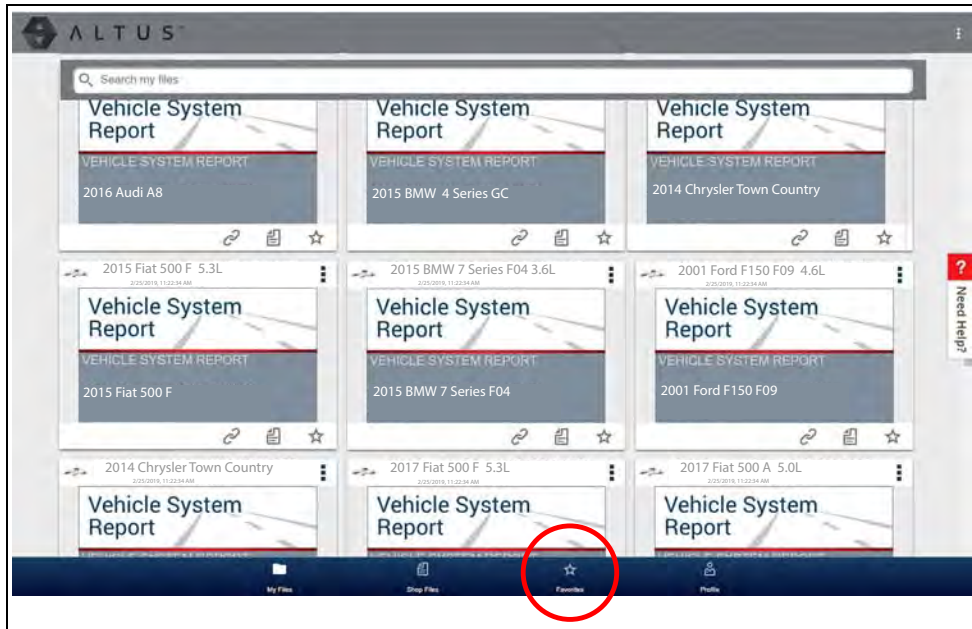

Figure 15-21

To set a file as a "Favorite", select the **Favorite** icon (star symbol) to highlight the icon.

Description	Icon
Favorite (on)	
Favorite (off)	

The Favorites icon can be selected/deselected at anytime when displaying files.

15.4.7 Profile

Select Profile (Figure 15-22) to open the Profile Manager menu.

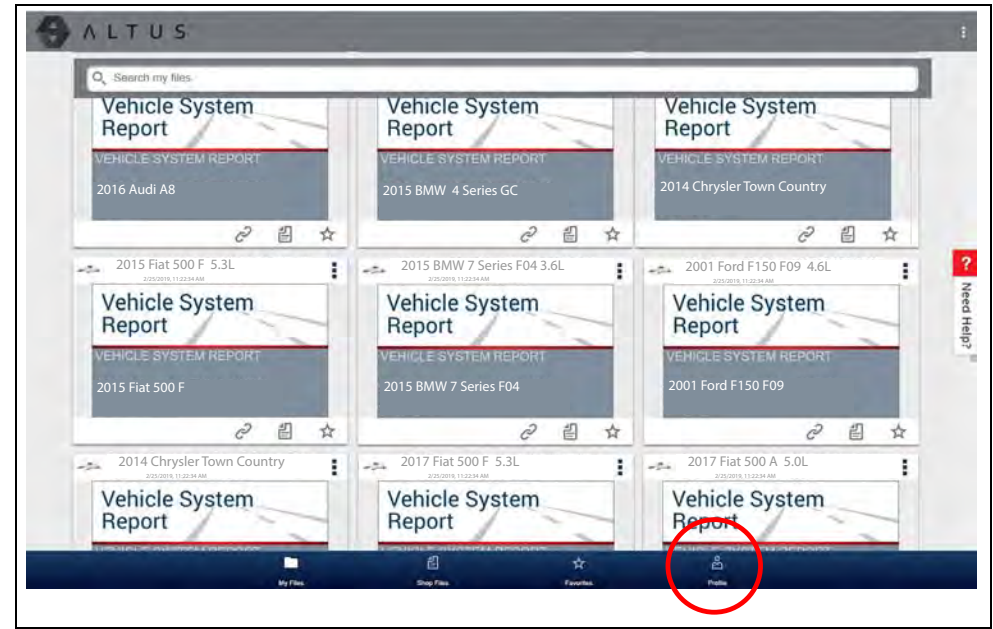

Figure 15-22

The Profile Manager Menu screen (*Figure 15-23*) allows you to:

- Open Profile Manager, see *Using Profile Manager on page 141*
- Logout of The Snap-on Cloud, see *Logging Out of The Snap-on Cloud on page 143*
- Add others to your Network, see *Logging Out of The Snap-on Cloud on page 143*
- Open online Help, to assist in Registering Your Device

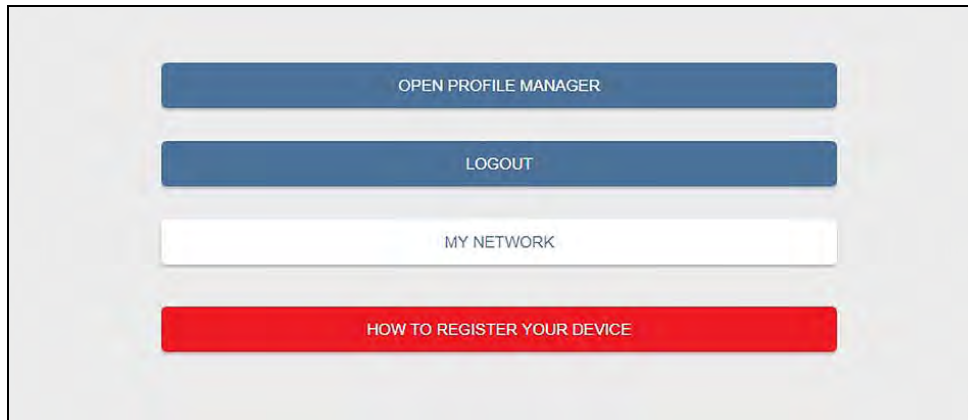

Figure 15-23

My Network

Selecting **My Network** (*Figure 15-23*) allows you to add others to your file sharing network. Enter the contacts name, phone number and/or email at the prompt. Add as many contacts as you need.

The Contact Names you enter will appear in the “Share Link” pop-up screen (*Figure 15-25*) when you select the **Link** icon (*Figure 15-24*).

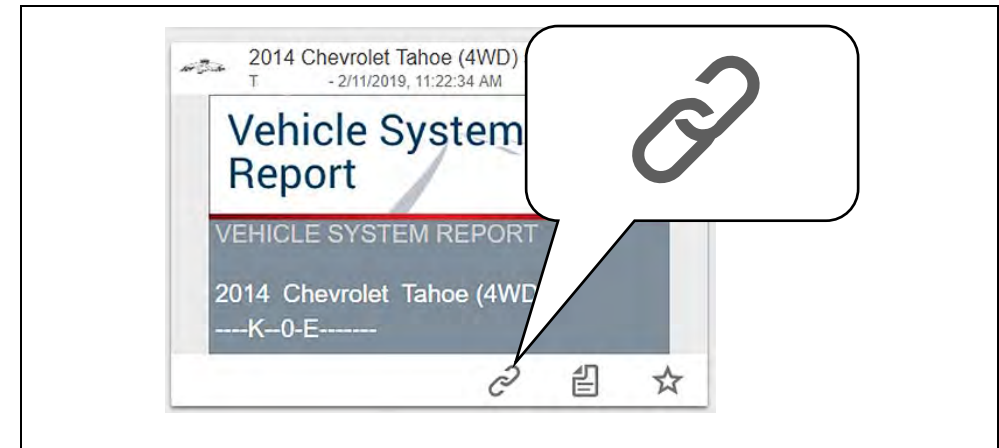

Figure 15-24



Figure 15-25



Using Profile Manager

To open the Profile Manager screen, select **Profile** from lower toolbar, then select **Open Profile Manager** (Figure 15-23).

NOTE

Profile Manager opens a new browser tab. To return to The Snap-on Cloud after logging out of Profile Manager, you must select The Snap-on Cloud Home Page browser tab.

Enter your **Username** and **Password** at the Login screen.

Profile Manager includes five tabbed categories to help you manage your account information:

- [Account](#) on page 141
- [Personal Information](#) on page 142
- [Profile Picture](#) on page 142
- [Device Management](#) on page 142

Account

This screen manages the following account information (Figure 15-26):

- Authorization Key (not required for Snap-on Cloud account registration)
- Account Expiration Date
- Shop Nickname
- Email
- Username
- Password

Figure 15-26



Personal Information

This screen manages the following personal account information ([Figure 15-27](#)):

- First Name
- Last Name
- City
- State
- Zip Code

Figure 15-27

Profile Picture

This screen allows you to personalize your profile picture, by selecting one of the provided images.

Shop Information

Shop Information allows you to enter the name address, and phone number for your shop. This information is included as a header on the report.

Figure 15-28

Device Management

This screen manages devices associated with your account ([Figure 15-29](#)):

Select **Add a Device** to setup and add an authorized device (e.g. Diagnostic diagnostic tool or Diagnostic Tool).

Enter the device:

- **Serial Number** - serial number of the device
- **PIN** - specific PIN associated to the device
- **Code** - authorization code specific to the device

Device Name - user define name

When finished select **Save** to save and link the device to your account.

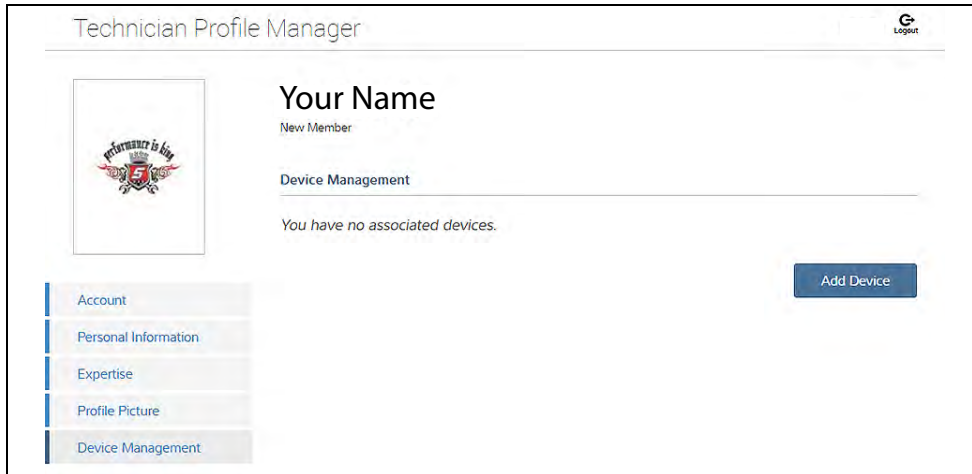

Figure 15-29

Logging Out of Profile Manager

Select the **logout** icon (upper right screen) to log out of Profile Manager (Figure 15-30).



Figure 15-30

NOTE

Profile Manager opens a new browser tab. To return to The Snap-on Cloud after logging out of Profile Manager, you must select The Snap-on Cloud Home Page browser tab.

Logging Out of The Snap-on Cloud

To log out of The Snap-on Cloud select **Profile** from lower toolbar, then select **Logout** (Figure 15-31).

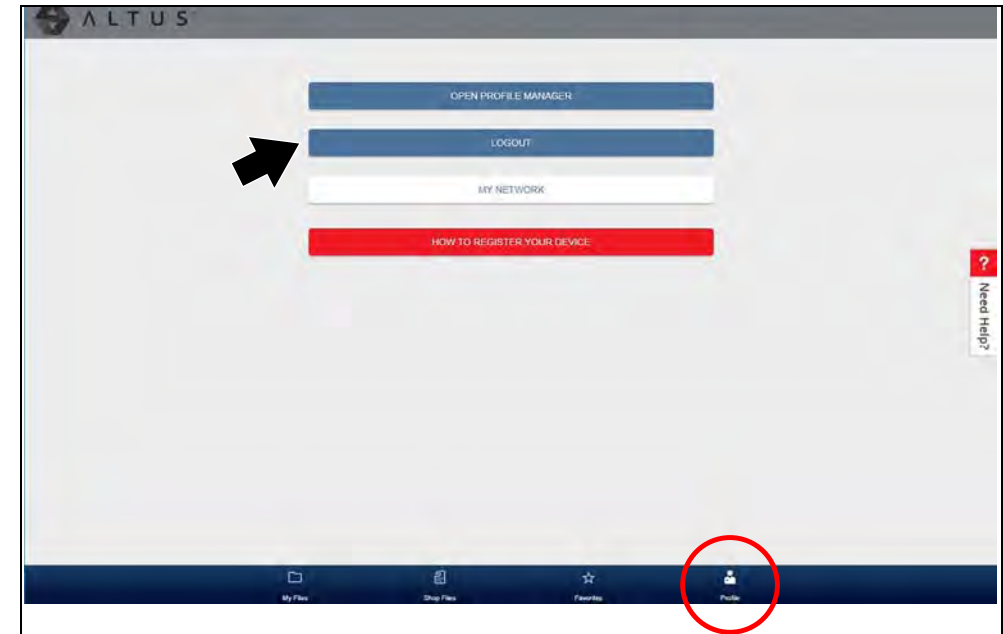

Figure 15-31



Introduction

This section provides a brief introduction to the features and operation of ShopStream Connect (SSC).

SSC is a companion PC application (provided at no charge) that extends the capabilities of your diagnostic tool, by connecting to your PC.

SSC allows you to:

- Print data files, screenshots and code scan reports
- Download software upgrades and updates to your PC, and then install them on to your diagnostic tool.
- Transfer data files bi-directionally between your diagnostic tool and your PC.
- View, save and manage your data files on your PC.
- Add or edit notes and comments to your data files.

The ShopStream Connect (SSC) software is available online at:

<https://www.snapon.com/diagnostics/UK/diagnostic-tools/shopstream-connect>

Complete ShopStream Connect operation instructions can be found in the ShopStream Connect User Manual, located online at:

<https://www.snapon.com/diagnostics/uk/User-Manuals.htm>

Main Topic Links

- [Using SSC \(Connecting to your PC\) page 144](#)
- [SSC Main Screen page 145](#)
- [Scanner DataViewer page 146](#)
- [Image Viewer page 146](#)
- [Printing the \(Code Scan\) Vehicle System Report page 147](#)
- [Customizing the \(Code Scan\) Vehicle System Report page 148](#)
- [Software Upgrades and Updates page 150](#)

16.1 Using SSC (Connecting to your PC)



To connect and use SSC with your diagnostic tool:

Download and install SSC on your PC from:

<https://www.snapon.com/diagnostics/UK/diagnostic-tools/shopstream-connect>

Turn your diagnostic tool on.

1. Connect the supplied USB cable from the USB jack on your diagnostic tool to your PC:
2. From the diagnostic tool Home screen, select **Tools > Connect-to-PC**.

The “**Device is now in Connect-to-PC mode**” screen message is displayed (*Figure 16-1*) and the ShopStream Connect software will open automatically on your PC (*Figure 16-2*).

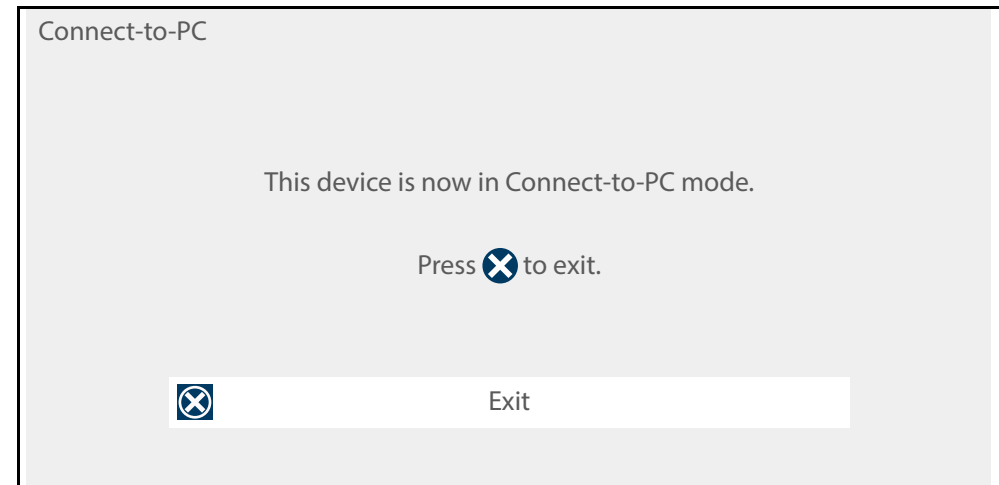

Figure 16-1

If the ShopStream Connect software does not open, open it from the Windows Start menu or use the ShopStream Connect shortcut icon on the Windows desktop (automatically created during installation).

16.2 SSC Main Screen

The ShopStream Connect software will open automatically when you connect the diagnostic tool to your PC USB connection, *Using SSC (Connecting to your PC) on page 144*.

The following shows the main screen layout for ShopStream Connect software.

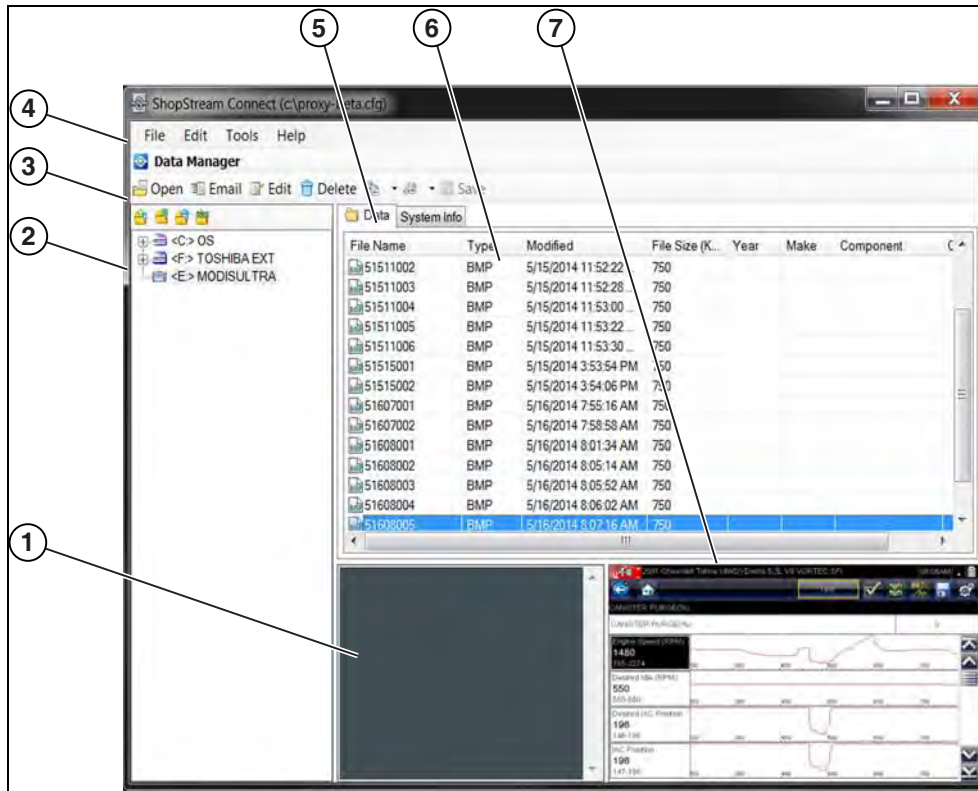

Figure 16-2

- 1— **Notes Window**—allows you add notes to select data files. Select Save from the menu bar to save your notes. *NOTE: Not all file types allow notes, the Notes window will be grayed out when a file type that does not support notes is highlighted. Some image files may display notes for reference purposes (the notes are grayed out and not editable).*
- 2— **File directory structure**—displays the file directory structure of your PC in standard Windows format, and shows any connected diagnostic tools at the bottom of the data list.

- 3— **Data Manager Toolbar**—provides control icons that perform a variety of operations on data files.
- 4— **Main Menu bar**—contains **File**, **Edit**, **Tools**, and **Help** menus.
- 5— **Tabs**—provides access to data files and presets stored on the diagnostic tool or on the PC, and also allows viewing of software revision details of the diagnostic tool.
- 6— **Main display**—shows stored data files details. *NOTE: The files listed are sortable (ascending/descending) by clicking on the column tab at the top (e.g. File Name, Type, etc.) Sort preferences are saved when the ShopStream Connect program is closed.*
- 7— **Preview**—displays a sample of the file if the selected file is a image file.

16.3 Scanner DataViewer

SSC allows you to view data files recorded with your diagnostic tool, on your PC. When a Scanner data file is selected, it opens and displays in the Scanner DataViewer (Figure 16-3). Scanner DataViewer allows you play the data file and custom configure the data in a number of ways.



- 1— Menu bar
- 2— Display toolbar
- 3— Graph display
- 4— Properties icon
- 5— Vertical Scroll bar
- 6— Zoom controls
- 7— Slider bar
- 8— Navigation toolbar
- 9— Parameter text list
- 10—Highlighted PIDs - indicates graphs currently displayed
- 11—Parameter configuration tabs

Figure 16-3

16.4 Image Viewer

SSC allows you to view and print .bmp, .jpg and .sps image files (screenshots) saved on your diagnostic tool, with your PC.

NOTE

File extension types vary depending on the diagnostic tool. Not all the file extensions described here may be available on your diagnostic tool.



- 1— Exit - closes the Image Viewer
- 2— Print - prints the image
- 3— Print Preview - allows the image to be previewed before printing
- 4— Captured Screen Image

Figure 16-4

16.5 Printing the (Code Scan) Vehicle System Report

To print the Vehicle System Report, the saved code scan .XML file must be opened using ShopStream Connect.

To print the Vehicle System Report using ShopStream Connect:

1. Double-click the code scan .XML file from the file list to open the Vehicle System Report (Figure 16-5) in the Code Scan Viewer (Figure 16-6).

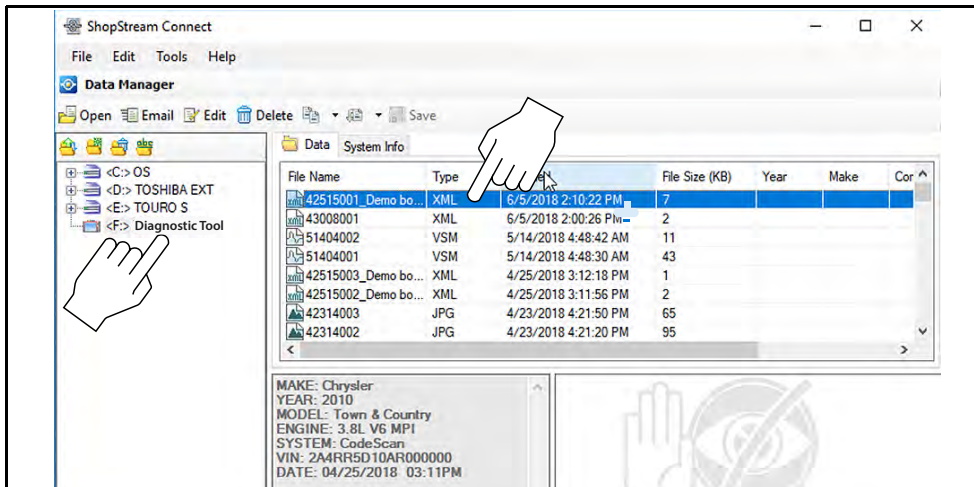

Figure 16-5

2. Select **Print** or **Print Preview** from the Code Scan Viewer menu to print or preview the Vehicle System Report (Figure 16-6).



Figure 16-6

Selecting **Print** opens the Windows print dialog window (Figure 16-7). Select your printer from the list, then select **Print** to print the report.

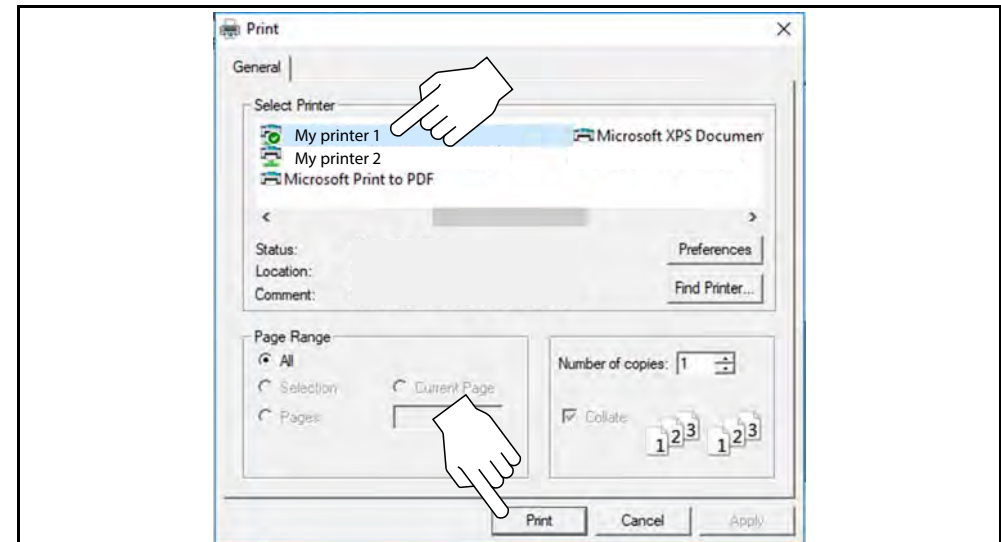

Figure 16-7



16.6 Customizing the (Code Scan) Vehicle System Report

Select fields of the Vehicle System Report can be edited, and you can also add notes to the report using ShopStream Connect.

To add Pre Scan or Post Scan to the report header:

1. Double-click the code scan .XML file from the file list to open the Vehicle System Report ([Figure 16-8](#)) in the Code Scan Viewer.
2. Hover the cursor over the area shown in [Figure 16-8](#), and select the desired option to add to the report header.

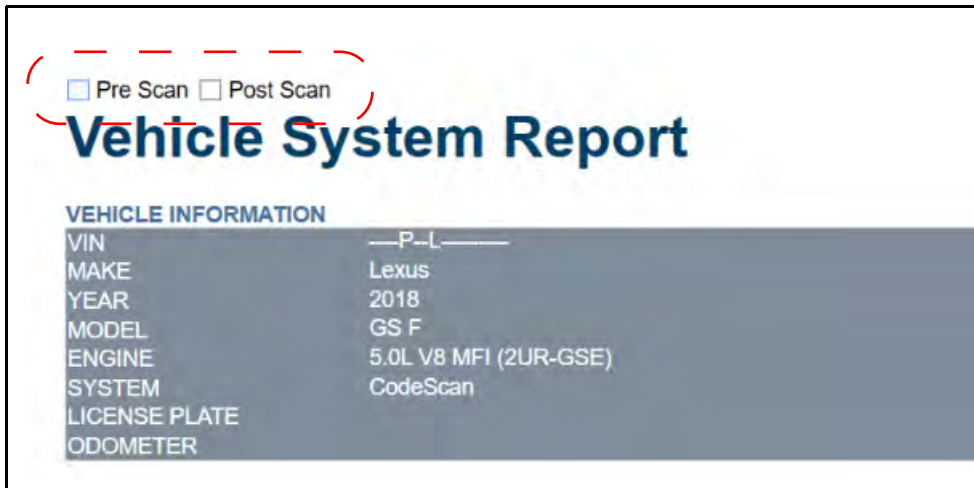

Figure 16-8

To edit the Shop Information (header) of the Vehicle System Report:

1. From ShopStream Connect, select **Tools > Options > Edit Shop Info** ([Figure 16-9](#)).

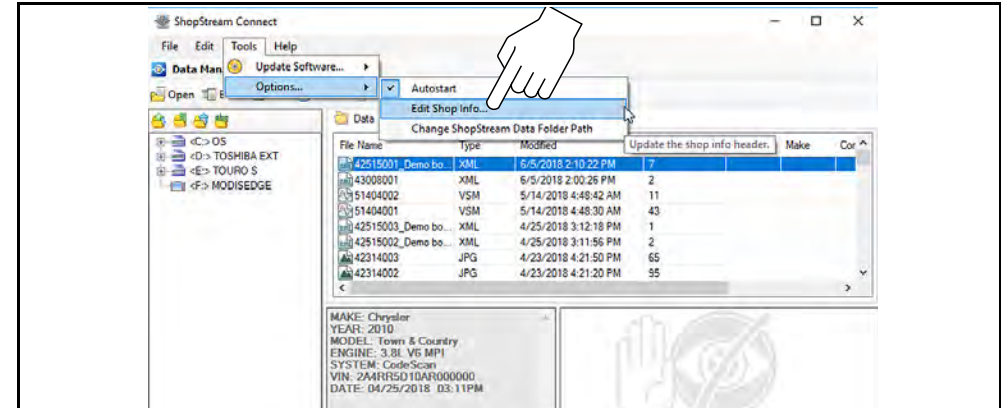

Figure 16-9

2. The **Shop Info** dialog box opens ([Figure 16-10](#)) allowing you to enter the name address, and phone number for your shop. This information is included as a header on the report.



Edit Shop Info

Shop Name: SampleShop
 Address 1: 1543 East Poplar
 Address 2:
 City: Madison
 State/Province, County: WI
 Zipcode: 57890
 Phone 1: 344-555-5555
 Phone 2:

Messages
 Line 1:
 Line 2:
 Line 3:

Use Shop Info in Printout Header
 Use timestamp in Vehicle System Report

Save Cancel

Print Header Preview

```
6/6/2018 2:57 PM
SampleShop
1543 East Poplar
Madison WI 57890
344-555-5555
```

Figure 16-10

A preview panel at the bottom of the box shows how the information will appear on a print out (Figure 16-10).

3. Check the “**Use Shop Info in Printout Header**” box to show the Shop Info in the printout (Figure 16-10).
4. Check the “**Use timestamp in Vehicle System Report**” box to show the time the vehicle was scanned in the printout (Figure 16-10).
5. When you are finished editing, select **Save** (Figure 16-10) to save the information and close the dialog box.

To edit the VIN and License Plate fields, and/or add notes to the Vehicle System Report:

1. From ShopStream Connect, open the code scan .XML file to be edited (Figure 16-11).
2. Click in the editable fields as shown in (Figure 16-11) to change the values or add notes.
3. Check the “**Add the notes to the printed copy**” box to show the notes in the printout (Figure 16-11).

42515001_Demo board Code Scan.XML - ShopStream Connect™ Scanner Codes Viewer

File Print Print Preview Help

2010 Chrysler Town & Country 3.8L V6 MPI

SampleShop
 1543 East Poplar
 Madison, WI 57890
 344-555-5555

Vehicle System Report

VEHICLE INFORMATION

VIN	
MAKE	Chrysler
YEAR	2010
MODEL	Town & Country
ENGINE	3.8L V6 MPI
SYSTEM	CodeScan
LICENSE PLATE	

NOTES

Add the notes to the printed copy

CODE SCAN RESULTS

System analyzed: 19

- ▲ Airbag: 5
- ▲ Airbag: 2
- ▲ Airbag: 2
- ▲ Central Gateway (FCM): 0
- ▲ Door Module - Front Left (DMFL): 2
- ▲ Door Module - Front Right (DMFR): 2
- ▲ Door Module - Rear Left (DMRL): 2
- ▲ Door Module - Rear Right (DMRR): 2
- ▲ Heat Ventilation A/C (HVAC): 1
- ▲ Instrument Cluster Module (CCN): 0
- ▲ Power Liftgate Module (PLGM): 1
- ▲ Power Sliding Door Module - Left (PSDML): 3
- ▲ Power Sliding Door Module - Right (PSDMR): 2

Figure 16-11



16.7 Software Upgrades and Updates

Upgrade/Update Descriptions:

- **Software Upgrade** - a software upgrade is a new software version (contact your sales representative for purchase information).
- **Software Update** - a software update is a service release for installed software. These are available free of charge, and are provided as necessary to update installed software. When your diagnostic tool is connected to a PC using SSC, the SSC software will automatically check for updates, and if an update is available, it will provide installation instructions. Follow the screen prompts to accept, download and install the software.

NOTE

To receive updates or upgrades, SSC software must be installed on your PC and have connection to the Internet.

- Example - Updating diagnostic tool software:**
1. Select **Tools > Update Software >** (diagnostic tool type - e.g. **ETHOS Edge, MODIS Edge, SOLUS Edge, etc.**) from the Menu bar (*Figure 16-12*).

The software checks the Snap-on web server for available updates.

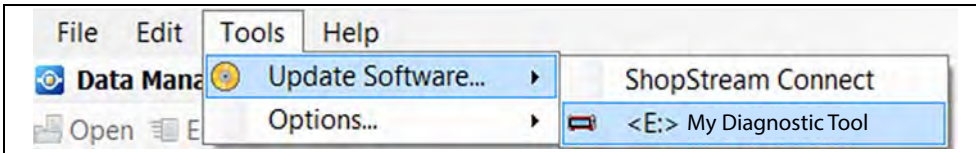

Figure 16-12

2. If service release updates are available, select **Next** to continue, then select **Download** and follow the on-screen instructions to complete the installation (*Figure 16-13*).

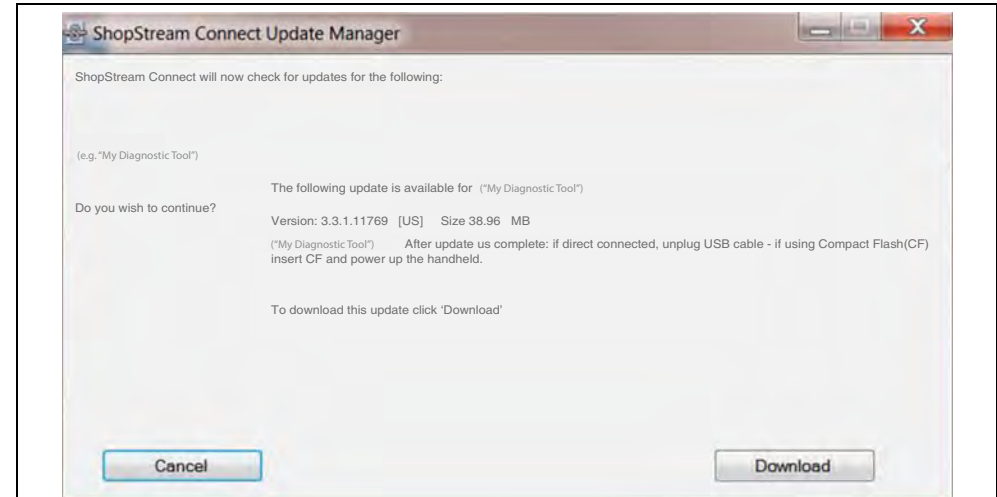

Figure 16-13

NOTE

For additional information on ShopStream Connect software updates and upgrades, download the ShopStream Connect User Manual from our website: <https://snapon.com/diagnostics/uk/User-Manuals.htm>

16.7.1 End User License Agreement

Before software installation at initial purchase, and before all subsequent software updates/upgrades installations End User License Agreement (EULA) acceptance is required.

IMPORTANT

Use of Software is governed by the terms and conditions of the End User License Agreement. The diagnostic tool should not be initially operated until the End User License Agreement is read. Use of the device acknowledges your acceptance of the End User License Agreement. The Snap-on Incorporated Software End User License Agreement is available at: <https://eula.snapon.com/diagnostics>

To Accept: at the screen prompt (*Figure 16-14*) click the checkbox on the left side of the window, and then select **Agree and Continue**. The software will be installed automatically.



Figure 16-14 below represents a typical EULA acceptance screen.

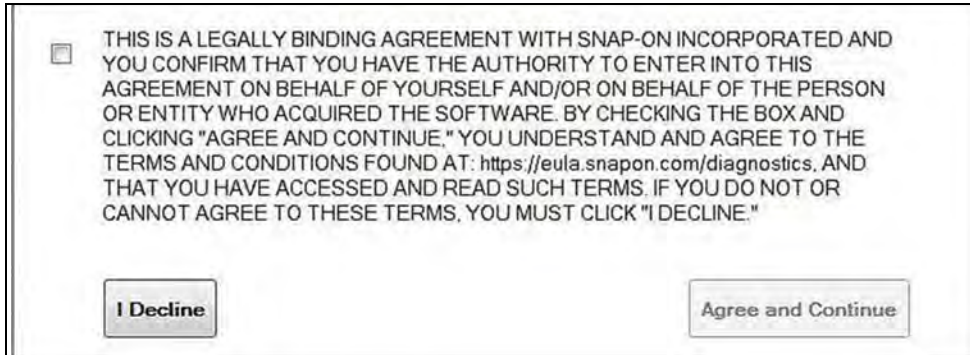

Figure 16-14 Typical EULA acceptance screen

To Decline: at the screen prompt ([Figure 16-14](#)) select **I Decline**. A confirmation message is displayed providing options to Go Back or Exit the software installation ([Figure 16-15](#)).

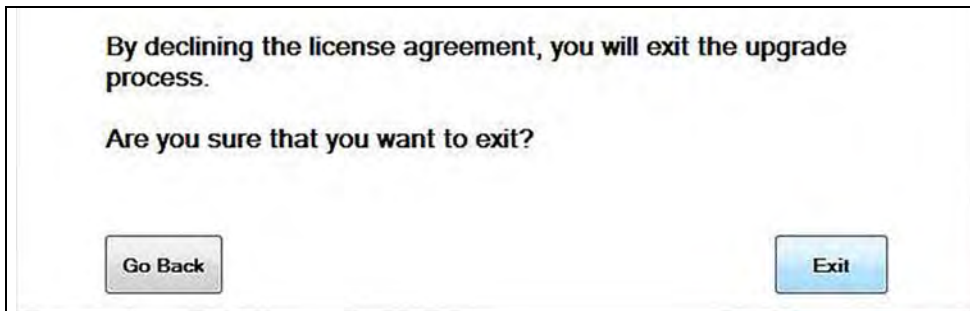

Figure 16-15 Typical EULA acceptance screen



This section describes basic cleaning and battery replacement procedures for your diagnostic tool.

Main Topic Links

- [Cleaning and Inspecting the Diagnostic Tool](#) page 152
- [Battery Pack Service](#) page 152
- [Cleaning the Touch Screen](#) page 152
- [Safety](#) page 152
- [Ordering a New Battery Pack](#) page 153
- [Removing / Installing the Battery Pack](#) page 153
- [Disposing of the Battery Pack](#) page 154

17.1 Cleaning and Inspecting the Diagnostic Tool

Periodically perform the following tasks to keep your diagnostic tool in proper working order:

- Check the housing, cables and connectors for dirt and damage before and after each use.
- At the end of each work day, wipe the diagnostic tool housing, cables and connectors clean with a damp cloth.

IMPORTANT

Do not use any abrasive cleansers or automotive chemicals on the diagnostic tool.

17.1.1 Cleaning the Touch Screen

The touch screen can be cleaned with a soft cloth and a mild window cleaner.

IMPORTANT

Do not use any abrasive cleansers or automotive chemicals on the touch screen.

17.2 Battery Pack Service

17.2.1 Safety

Follow all safety guidelines when handling the battery pack.



! WARNING

Risk of electric shock.

- **Prior to recycling the battery pack, protect exposed terminals with heavy insulating tape to prevent shorting.**
- **Disconnect all test leads and turn diagnostic tools off before removing the battery pack.**
- **Do not attempt to disassemble the battery or remove any component projecting from or protecting the battery terminals.**
- **Do not expose the diagnostic tool or battery pack to rain, snow, or wet conditions.**
- **Do not short circuit the battery terminals.**

Electric shock can cause injury.



WARNING

Risk of explosion.

- **The Lithium battery is factory replaceable only, incorrect replacement or tampering with the battery pack may cause an explosion.**

Explosion can cause death or serious injury.

IMPORTANT

The battery pack contains no user serviceable components. Tampering with the battery pack terminals or housing will void the product warranty.

Keep the following in mind when using and handling the battery pack:

- Do not short circuit battery pack terminals.
- Do not immerse the diagnostic tool or battery pack in water, or allow water to enter the diagnostic tool or battery pack.
- Do not crush, disassemble, or tamper with the battery pack.
- Do not heat the battery pack to over 100°C (212°F), or dispose of it in a fire.
- Do not expose the battery pack to excessive physical shock or vibration.
- Keep the battery pack out of reach of children.
- Do not use a battery pack that appears to have suffered abuse or damage.
- Charge the battery pack in the appropriate charger only.
- Do not use a battery charger that has been modified or damaged.
- Use the battery pack for the specified product only.
- Store the battery pack in a cool, dry, well ventilated area.

NOTE

The battery pack should be used within a short period of time (about 30 days) after charging to prevent loss of capacity due to self-discharging.

If long-term storage of the battery pack is necessary, it should be stored in a cool, dry, well ventilated place with a 30 to 75 percent state of charge to prevent loss of characteristics.

To prolong the life of your battery, turn off the diagnostic tool when not in use. The diagnostic tool has a built in charger that recharges the battery on demand whenever it is connected to a power source.

17.2.2 Ordering a New Battery Pack

If the battery pack needs to be replaced, contact your sales representative to order a new battery pack.

IMPORTANT

Only use the recommended Snap-on replacement battery pack.

17.2.3 Removing / Installing the Battery Pack

IMPORTANT

If replacing the battery pack, only use the recommended Snap-on replacement battery pack.



To remove the battery pack:

1. Loosen the two battery cover screws on the back-side of the diagnostic tool.
2. Pull up and out on the lower edge of the battery cover to release it.
3. Remove the battery pack in the same manner as the battery cover, pulling the bottom edge up and tilting out.



To install the battery pack:

1. Position the battery pack as shown below with the arrows facing up.
2. Tilt the top of the battery in to align the tabs, then down to install into place.
3. Install the battery pack cover, in the opposite manner as removal, aligning the tabs and tilting down and in, into place.
4. Tighten the battery cover screws. ***Do not overtighten the screws!***

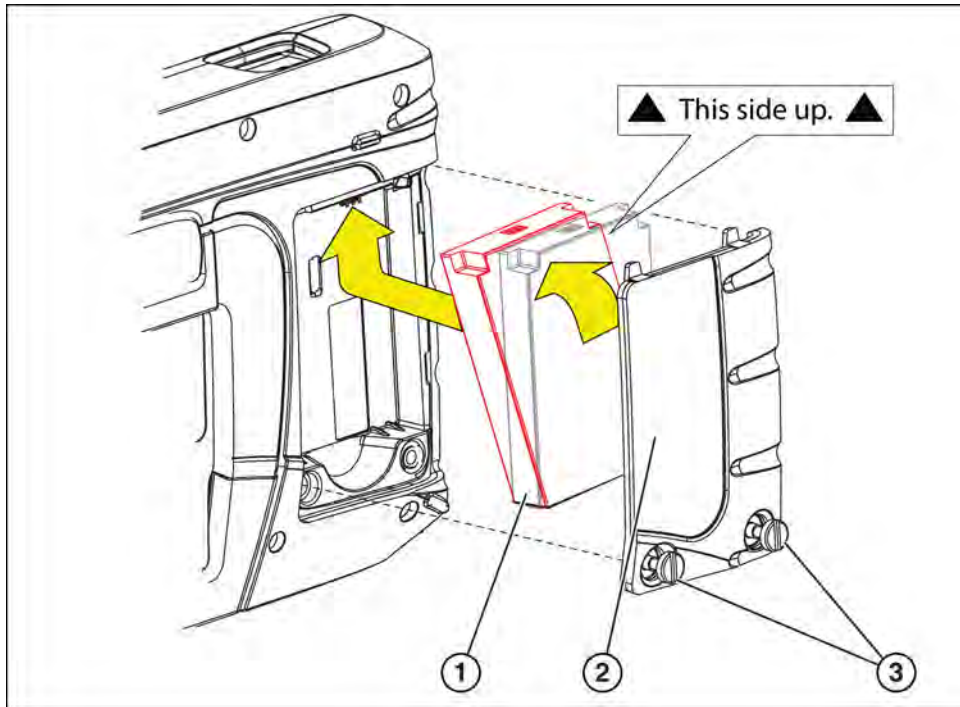

- 1— Battery Pack
- 2— Battery Cover
- 3— Battery Cover Screws

Figure 17-1 Battery pack

17.2.4 Disposing of the Battery Pack

Always dispose of the battery pack according to local regulations, which vary for different countries and regions. The battery pack, while non-hazardous waste, does contain recyclable materials. If shipping is required, ship the battery pack to a recycling facility in accordance with local, national, and international regulations.

IMPORTANT

Always dispose of materials according to local regulations.

For additional information contact:

- United Kingdom—Electrical Waste Recycling Company at:
<http://www.electricalwaste.com>

Products bearing the WEEE logo (*Figure 17-2*) are subject to European Union regulations.



Figure 17-2 WEEE logo

Contact your sales representative for details.



Customer Support / Training

Support Contact Information

Phone / E-mail - Technical Assistance

+44 (0) 845 6066512 / diagukps@snapon.com

Website Links:

Snap-on Diagnostics and Information

- <https://snapon.com/diagnostics/uk>

Manuals / Technical Documentation - This manual is periodically revised to ensure the latest information is included. Download the latest version of this manual and other related technical documentation at:

- <https://snapon.com/diagnostics/uk/User-Manuals.htm>

For technical assistance in all other markets, contact your selling agent.

Product Training Videos

Diagnostic tool specific training videos are available on our website. Follow along and learn the basics of diagnostic tool operation with our free training videos.

Videos are product specific and are available at:

<https://diagnostics.snapon.com> - Click on the "Training & Support" tab, select the applicable diagnostic tool, then select "See Training".

i NOTE

Sample titles are listed below. Not all titles may be available for all diagnostic tools, and are subject to change.

Snap-on® Training Solutions® - Training Videos (examples)	
Introduction and Navigation	Global OBD-II
Scanner Codes	Digital Multimeter
Scanner Data in PID View	Graphing Multimeter & Lab Scope
Scanner Data in Graphing View	Guided Component Tests
Fast-Track® Troubleshooter	Vehicle Specs & Resets
Functional Tests	SureTrack® & Wi-Fi



Diagnostic Quick Tips - Video Series

Snap-on Diagnostic Quick Tips videos are available at no charge on our website and on our YouTube channel. These videos are developed from real repair case studies to help professional technicians use diagnostic tools to solve specific vehicle problems (e.g. performing a Ford Relative Injector Flow Test).

Additional videos are also available showing specific diagnostic tool features (e.g. ShopStream Connect - Software Updates).



Figure 18-1

Videos are available at:

<http://diagnostics.snapon.com> - Click on the "Training & Support" tab, select the applicable diagnostic tool, then select "See Quick Tips"

<https://www.youtube.com/user/snaponscanner/videos> - Use the search function to find a title, or enter "Diagnostic Quick Tips" in the search field to see a list of all applicable titles.

NOTES

URL links (above) and titles listed (below) are subject to change and may not be available in all markets.

A sample list of titles are listed below, other titles may be available.

Some videos may not applicable for use with all diagnostic tools.

Snap-on® Training Solutions® - Diagnostic Quick Tips Videos (examples)

Air/Fuel Ratio Sensor Test	Fuel Injector Voltage and Current Tests (Scope)
Alternator Ripple Test (Scope)	Fuel Pump Current Ramp Test (Scope)
BMW® Rain Sensor Calibration	Harley-Davidson® ABS Brake Bleed
CAN Bus Diagnostics (Scope)	Harley-Davidson® Functional Tests
Chevrolet® Volt Coolant Pump Bleed	Harley-Davidson® Key Fob Programming
Chrysler HVAC Test	Hyundai Blind Spot Detection System Calibration
Chrysler VVT System Cleaning	Hyundai Occupant Detection System Reset
Chrysler Wheel & Tire Calibrations	Ignition Coil Current and Voltage Comparison
COP Ignition Test	Ignition Coil Current Ramp Test
Dual Screen Diagnostics: Scanner vs. Scope	Ignition Coil Primary Voltage Test
Electronic Throttle Control System Diagnostics	Ignition System Diagnostics Using the SIA2000 (Scope)
FIAT® 500 Proxi Alignment	MINI Battery Relearn
FIAT® 500 Throttle Body Relearn	Multi Channel Cam / Crank Correlation
Flex Ray Bus Diagnostics	OBD-II Mode 10 Permanent Codes
Ford Battery Monitor System	Oil Specs & Service Light Resets
Ford Coil Current RFI Test (Scope)	PID Trigger Functions (Scanner)
Ford Flash Reprogramming	Piezo Injectors Signature Test
Ford Misfire Monitor Neutral Profile Correction (Scanner)	Relative Compression Test (Scope)
Ford PATS Key Programming	ShopStream Connect - Data Manipulation
Ford Relative Compression Test	ShopStream Connect - Software Updates



Snap-on® Training Solutions® - Diagnostic Quick Tips Videos (examples)	
Ford Relative Injector Flow Test	Speed Up Your Diagnostics (Scanner)
Ford TPMS Reprogramming	The Power of Troubleshooter Tips (Scanner)
Ford® 6.7L Transmission Solenoid Characterization	Top Level Menus: Built In Scope Training
Ford® Diesel Injector Coding	Toyota EVAP Test
VW / Audi Flexible Service Reset (Scanner)	Toyota Multiple Freeze Frame (Scanner)
	Toyota Transmission Compensation Coding



Legal Information

Trademarks

Snap-on and SureTrack are trademarks registered in the United States and other countries of Snap-on Incorporated. All other marks are trademarks or registered trademarks of their respective holders.

Copyright Information

© 2019 Snap-on Incorporated. All rights reserved.

Software License Information

Use of Software is governed by the terms and conditions of the End User License Agreement. The diagnostic tool should not be initially operated until the End User License Agreement is read. Use of the device acknowledges your acceptance of the End User License Agreement. The Snap-on Incorporated Software End User License Agreement may be provided with the diagnostic tool, and is available at:

<https://eula.snapon.com/diagnostics>

Patent Information

For a listing of Snap-on products that are protected by patents in the United States and elsewhere, visit: <https://patents.snapon.com>

Manual Application

This manual includes information and images applicable to diagnostic software version 19.4. Some information within this manual may not be applicable to other diagnostic software versions.

Disclaimer of Warranties and Limitation of Liabilities

All pictures and illustrations shown are for reference purposes only. All information, specifications and illustrations in this manual are based on the latest information available at the time of printing and are subject to change without notice. While the authors have taken due care in the preparation of this manual, nothing contained herein:

- Modifies or alters in any way the standard terms and conditions of the purchase, lease, or rental agreement under the terms of which the equipment to which this manual relates was acquired.
- Increases in any way the liability to the customer or to third parties.

Snap-on® reserves the right to make changes at any time without notice.

IMPORTANT

Before operating or maintaining this unit, please read this manual carefully paying extra attention to the safety warnings and precautions.

Manuals / Technical Documentation - The information in this manual is periodically revised to ensure the latest information is included. Download the latest version of this manual and other related technical documentation from the Snap-on Diagnostics website.